



# Ultra-Reliable KEA Automotive Microcontrollers (MCUs) based on Arm® Cortex®-M0+ Core

## KEA

Last Updated: May 20, 2022

Kinetis® EA series of 32-bit Arm® Cortex® MCUs are targeted for a wide range of automotive and industrial applications requiring the highest level of quality and longevity support. The Kinetis EA series is an entry point to the broad Arm ecosystem and features:

- A low-power Arm Cortex-M0+ core and 8–128 KB of embedded flash
- Excellent EMC/ESD, high temperature, and low radiated emissions
- Scalable, highly robust performance solution for cost-sensitive automotive applications
- A broad set of reference designs, tools and application notes to help shorten design development and speed time-to-market

### 3 Phases Sensorless BLDC Motor Control Block Diagram

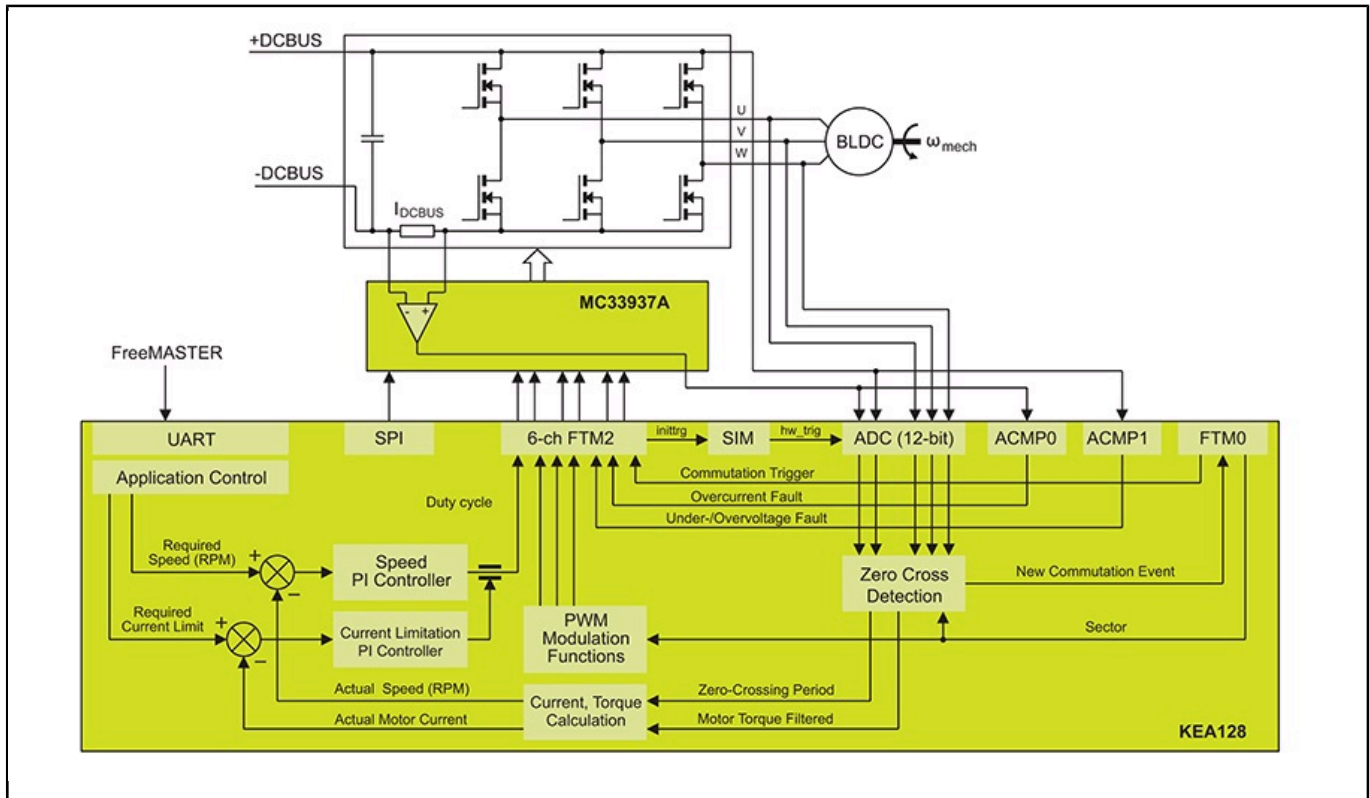

View additional information for [Ultra-Reliable KEA Automotive Microcontrollers \(MCUs\) based on Arm® Cortex®-M0+ Core](#).

**Note:** The information on this document is subject to change without notice.

[www.nxp.com](http://www.nxp.com)

NXP and the NXP logo are trademarks of NXP B.V. All other product or service names are the property of their respective owners. The related technology may be protected by any or all of patents, copyrights, designs and trade secrets. All rights reserved. © 2022 NXP B.V.