



# **KV Series Quad Motor Control**

## **KINETIS-DRONE-REFERENCE-DESIGN**

Last Updated: Nov 15, 2022

The quadcopter drone consists of a flight controller and four electronic speed controllers (ESCs), one for each motor. The flight controller is equipped with a radio to receive flight commands from the pilot and the inertial measurement unit (IMU). This reference design combines four separate ESC boards into one controlled by a single KV4x or KV5x MCU, and is capable of driving four BLDC motors.

## Quad Motor Control Block Diagram

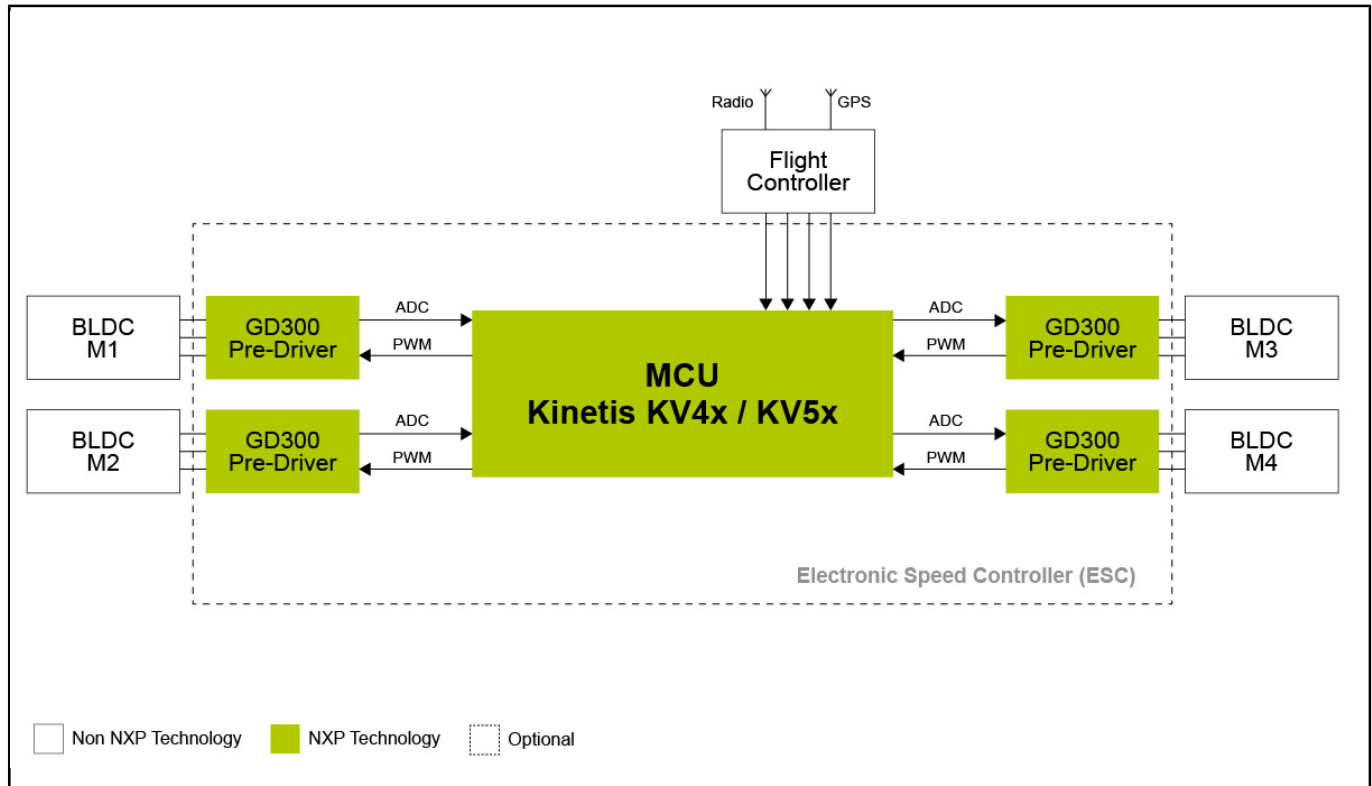

View additional information for [KV Series Quad Motor Control](#).

**Note:** The information on this document is subject to change without notice.

[www.nxp.com](http://www.nxp.com)

NXP and the NXP logo are trademarks of NXP B.V. All other product or service names are the property of their respective owners. The related technology may be protected by any or all of patents, copyrights, designs and trade secrets. All rights reserved. © 2023 NXP B.V.