



Airbag Power Supply and PSI5 Sensor Interface

MC33789

Last Updated: Jan 19, 2024

The NXP® MC33789 is a mixed signal IC for airbag safety applications that provides a cost-effective and flexible system IC solution across the range of airbag partitions used in cars and other vehicles.

- Connects to the 12 V vehicle battery and supplies the multiple voltages of a typical airbag system
- Can detect switched input states and communicate with both local and remote crash sensors
- Offers an industry standard interface (SPI) and four PSI5 leader interfaces
- Diagnostic - self protection capability and a programmable analog interface accessible by the system MCU
- The MC33789 is a [SafeAssure® functional safety solution](#).

Freescale MC33789 Network Transceivers Block Diagram Block Diagram

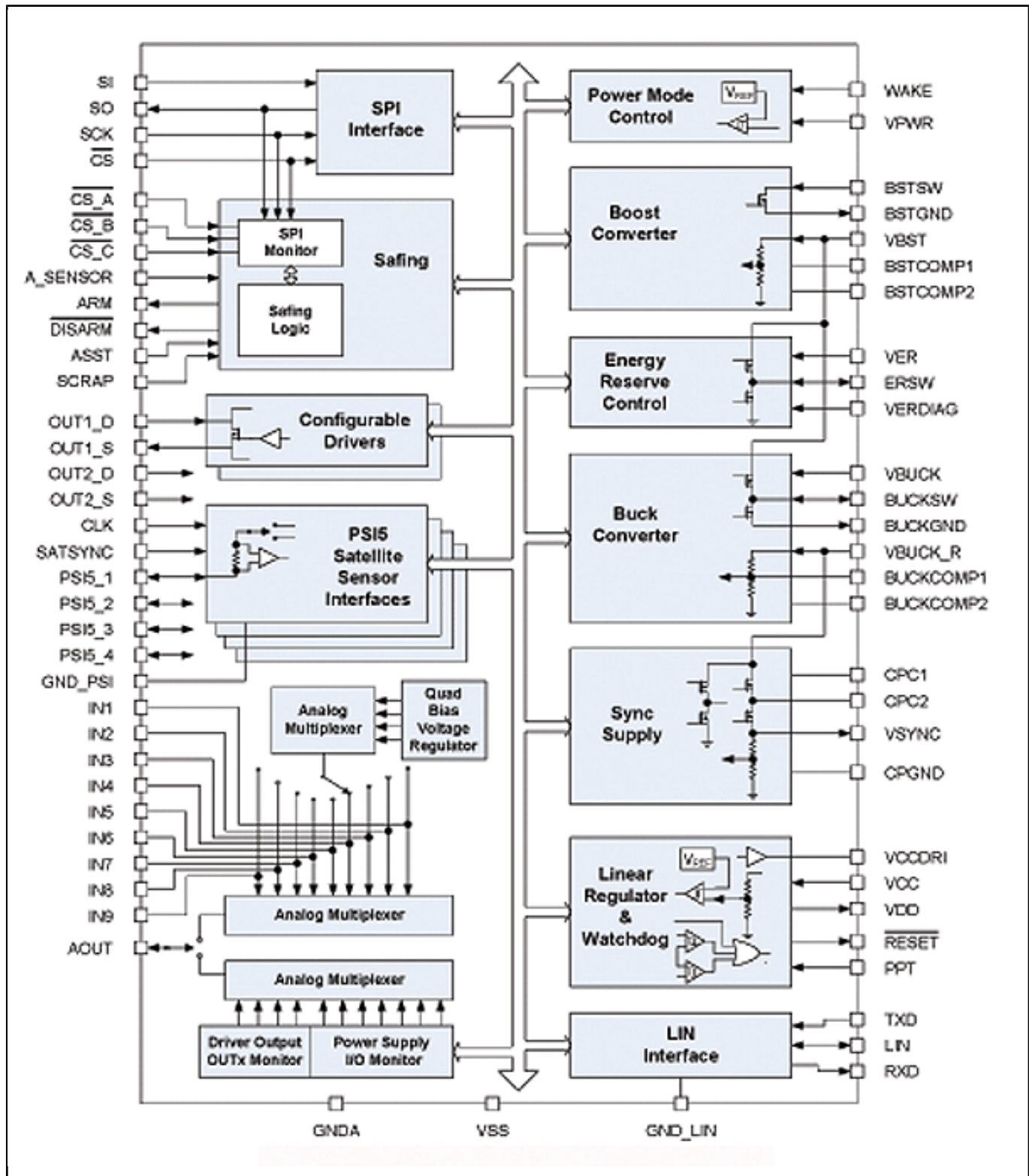

View additional information for [Airbag Power Supply and PSi5 Sensor Interface](#).

Note: The information on this document is subject to change without notice.

www.nxp.com

NXP and the NXP logo are trademarks of NXP B.V. All other product or service names are the property of their respective owners. The related technology may be protected by any or all of patents, copyrights, designs and trade secrets. All rights reserved. © 2024 NXP B.V.