



# H-Bridge Gate Driver IC

## MC33883

### Not Recommended for New Designs

This page contains information on a product that is not recommended for new designs.

Last Updated: Nov 7, 2023

The NXP® MC33883 is an H-bridge gate driver (also known as a full-bridge pre-driver) IC with integrated charge pump and independent high and low side gate driver channels.

- The gate driver channels are independently controlled by four separate input pins, allowing the device to be optionally configured as two independent high side gate drivers and two independent low side gate drivers
- The low side channels are referenced to ground. The high side channels are floating
- The gate driver outputs can source and sink up to 1.0 A peak current pulses, permitting large gate-charge MOSFETs to be driven and/or high pulse-width modulation frequencies
- Linear regulator providing a 15 V typical gate supply

## H-Bridge Gate Driver IC Block Diagram

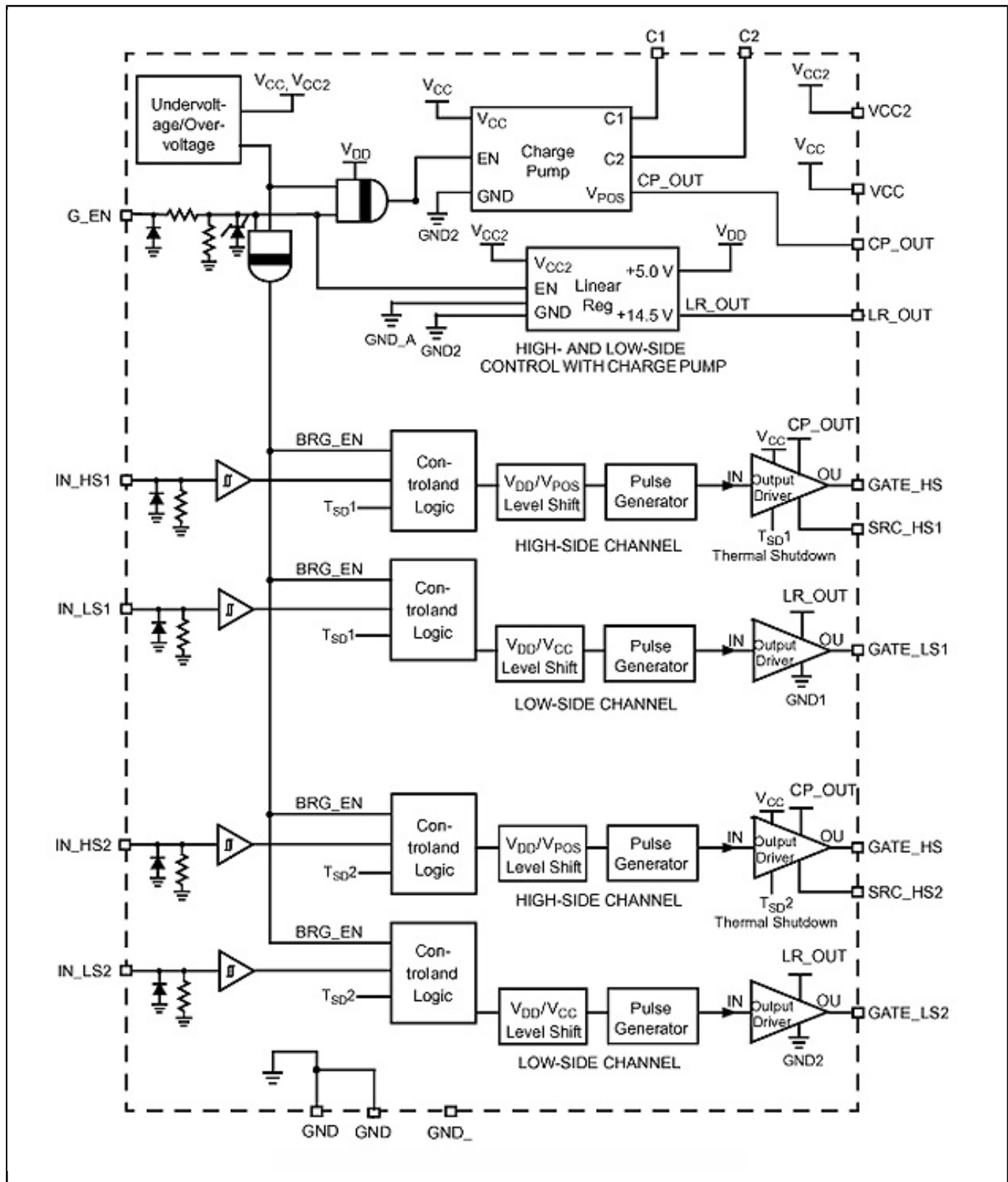

View additional information for [H-Bridge Gate Driver IC](#).

**Note:** The information on this document is subject to change without notice.

---

**[www.nxp.com](http://www.nxp.com)**

NXP and the NXP logo are trademarks of NXP B.V. All other product or service names are the property of their respective owners. The related technology may be protected by any or all of patents, copyrights, designs and trade secrets. All rights reserved. © 2023 NXP B.V.