



H-Bridge, Brushed DC Motor Driver, 5–28 V, 5 A, 10 kHz

MC33886

Last Updated: Feb 12, 2025

The NXP® MC33886 is a monolithic power IC comprising control logic, charge pump, gate drive, and low RDS(ON)MOSFET output H-Bridge circuitry in a small surface mount package.

- Six integrated low side drivers, three pre-drivers, a variable reluctance sensor input circuit, a voltage pre-regulator using an external pass transistor and two 5.0 volt internal regulators, one for the MCU VCC supply and one for use as a protected sensor supply
- The current drive can be pulse-width modulated at frequencies to 10 kHz
- Undervoltage, overtemperature, and overcurrent conditions are detected and reported via a status flag output
- Typical applications include: DC-motor acme lead screw actuators, servo gear actuators, bi-directional thrust solenoids, and fractional horsepower DC-motor control
- The KIT33887EKEVBE is the recommended evaluation board for the MC33886

H-Bridge, Brushed DC Motor Driver, 5-28V, 5A, 10kHz Block Diagram

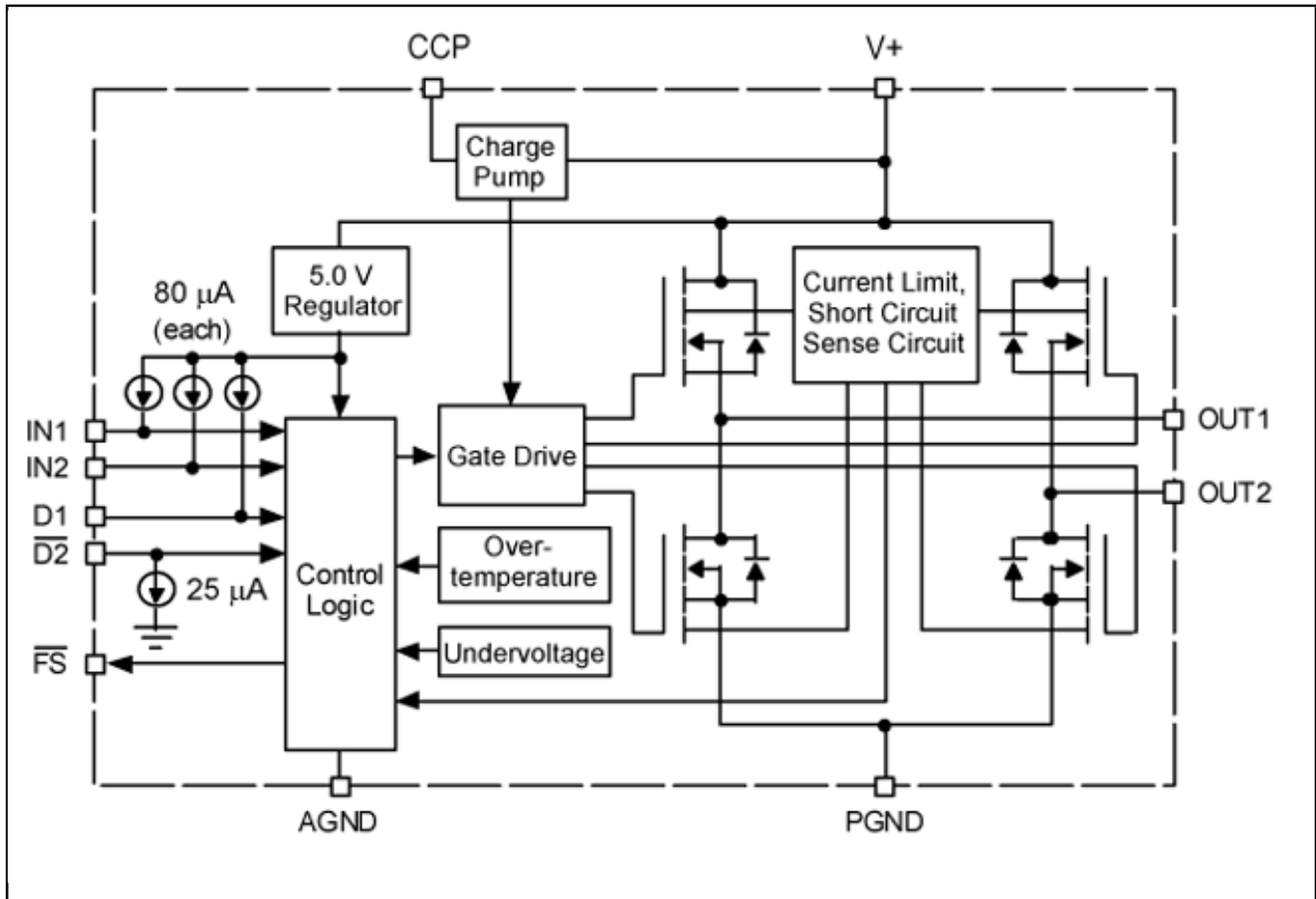

View additional information for [H-Bridge, Brushed DC Motor Driver, 5-28 V, 5 A, 10 kHz](#).

Note: The information on this document is subject to change without notice.

www.nxp.com

NXP and the NXP logo are trademarks of NXP B.V. All other product or service names are the property of their respective owners. The related technology may be protected by any or all of patents, copyrights, designs and trade secrets. All rights reserved. © 2025 NXP B.V.