



16-Output Switch with SPI and PWM Control

MC33999

Last Updated: Jul 6, 2022

The NXP® MC33999 is a 16-output low-side switch with a 24-bit serial input control, designed for a variety of applications including inductive, incandescent, and LED loads.

- The SPI provides both input control and diagnostic readout
- Eight parallel inputs are also provided for direct PWM control of 8 dedicated outputs
- An output programmable PWM input provides PWM of any combination of outputs
- A dedicated reset input provides the ability to clear all internal registers and turn all outputs off
- Interfaces with MCUs and compatible with both 3.3 V and 5.0 V CMOS logic levels
- Serves as a bus expander and buffer with fault management features, reducing the MCU fault management burden

Freescale MC33999 Low Side Switch Block Diagram Block Diagram

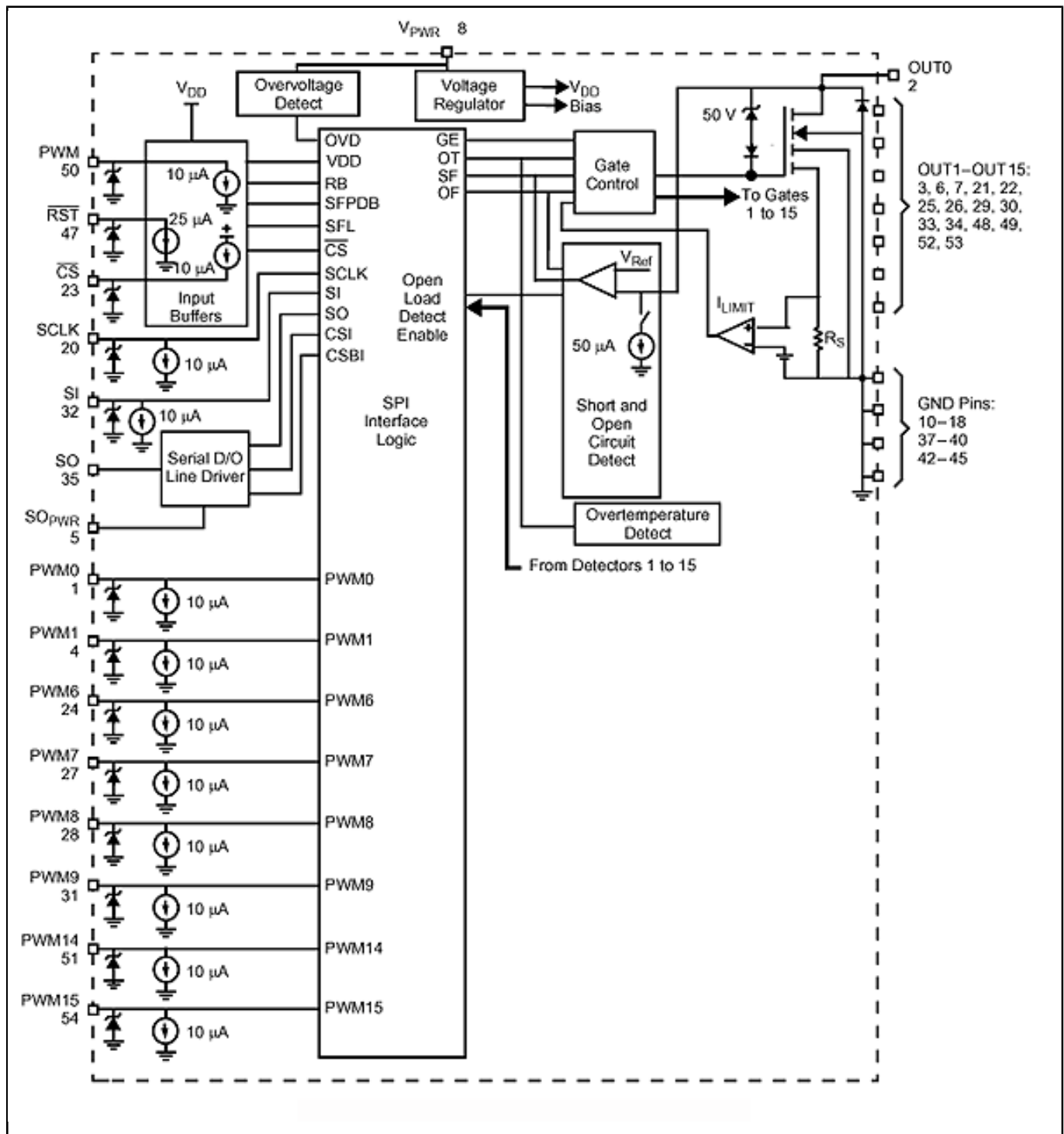

View additional information for [16-Output Switch with SPI and PWM Control](#).

Note: The information on this document is subject to change without notice.

www.nxp.com

NXP and the NXP logo are trademarks of NXP B.V. All other product or service names are the property of their respective owners. The related technology may be protected by any or all of patents, copyrights, designs and trade secrets. All rights reserved. © 2022 NXP B.V.