



MCX W72 Secure and Ultra-Low-Power MCUs for Bluetooth LE, Channel Sounding, Matter, Thread, Zigbee

MCX-W72

Active

Last Updated: Apr 30, 2026

The MCX W72 family features a 96 MHz Arm® Cortex®-M33 core coupled with a multiprotocol radio subsystem supporting Matter, Thread, Zigbee and Bluetooth LE. The independent radio subsystem, with a dedicated core and memory, offloads the main CPU, preserving it for the primary application and allowing firmware updates to support future wireless standards. The MCX W72 also offers advanced security with an integrated EdgeLock® Secure Enclave Core Profile and will be supported by NXP's EdgeLock 2GO cloud services for credential sharing.

The MCX W72 family includes Bluetooth Channel Sounding capabilities, with a dedicated on-chip Localization Compute Engine to reduce ranging latency. It incorporates additional memory to support application-specific code, connectivity stacks and over-the-air firmware updates. In addition, the radio subsystem can run the full Thread or Zigbee stack alongside the Bluetooth Low Energy stack. This delivers reliable wireless performance, as the real-time activities of the radio run on a separate core from the application.

Building on NXP's strong history of providing industrial edge solutions, the MCX W series offers a wide operating temperature range from -40 °C to 125 °C and peripherals for industrial applications, including an optional CAN interface and will be part of NXP's 15-year Product Longevity program to support long-term industrial use.

The MCX W series is supported by the [MCUXpresso Developer Experience](#) to optimize, ease and help accelerate embedded system development.

MCX W72 Block Diagram

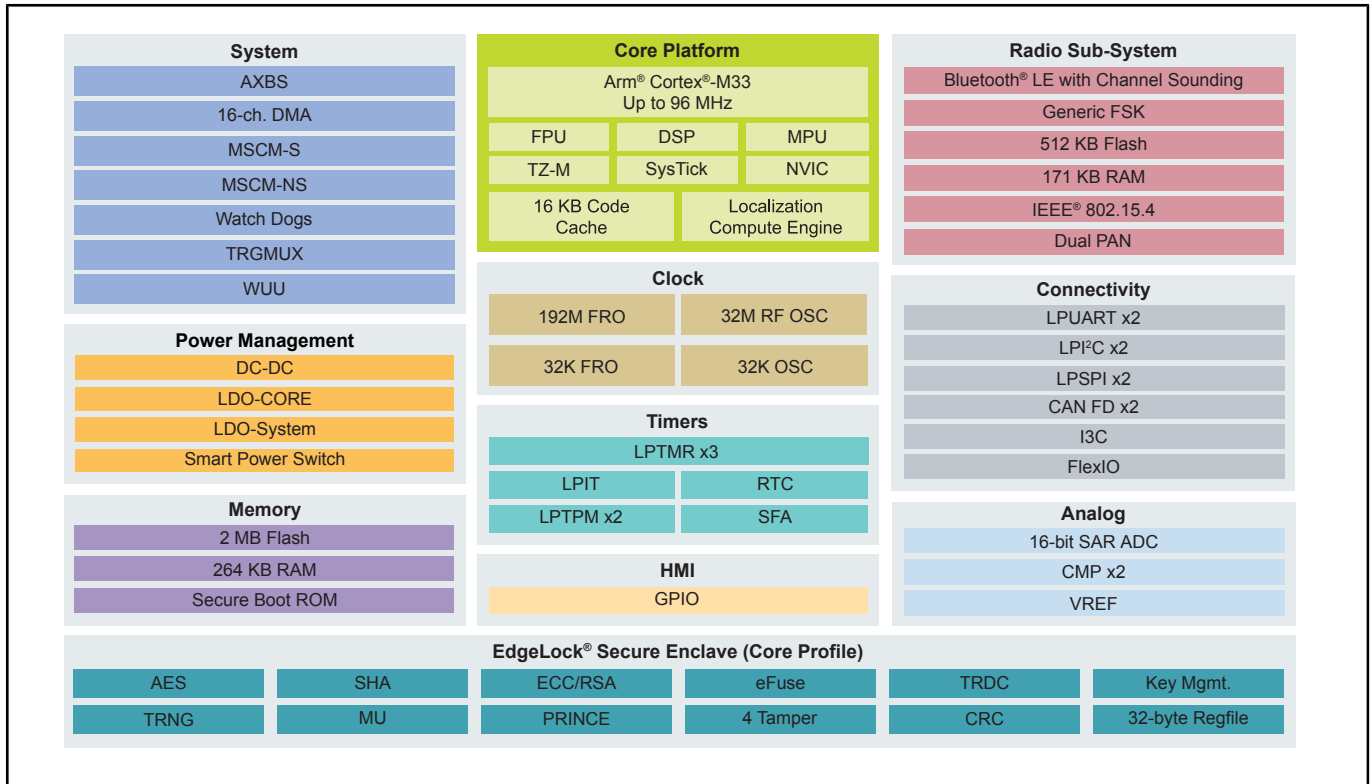

MCX W72 Architecture Block Diagram

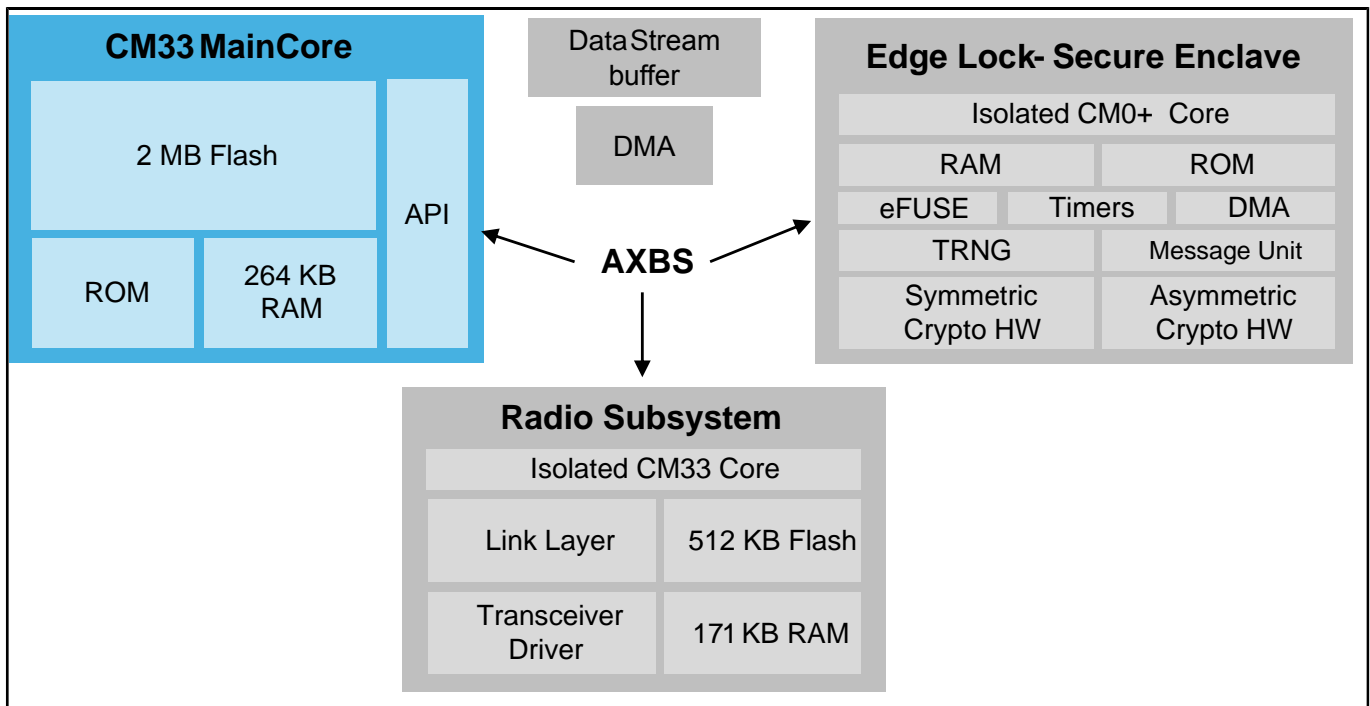

View additional information for [MCX W72 Secure and Ultra-Low-Power MCUs for Bluetooth LE, Channel Sounding, Matter, Thread, Zigbee.](#)

Note: The information on this document is subject to change without notice.

www.nxp.com

NXP and the NXP logo are trademarks of NXP B.V. All other product or service names are the property of their respective owners. The related technology may be protected by any or all of patents, copyrights, designs and trade secrets. All rights reserved. © 2026 NXP B.V.