



Low-Power PowerQUICC® II Pro Processor with DDR2, TDM, PCI, Security, USB, QUICC Engine®

MPC8321E

Last Updated: Sep 11, 2024

The MPC8321E PowerQUICC® II Pro is a member of the MPC8323E family of cost-effective network communications processors that meet the requirements of several small office/home office (SOHO), access, IP services and industrial control applications. It provides better CPU performance, additional functionality and faster interfaces than current PowerQUICC™ II processors while addressing important time to market, price, power consumption and board real estate requirements

Core Complex The MPC8321E incorporates a unique configuration of the e300c2 (MPC603e-based) core. While this version of e300 core does not have a Floating-Point Unit (FPU) it has been designed to include dual integer units as well as a modified multiply instruction. These architectural enhancements enable more efficient operations to be executed in parallel, resulting in significant performance improvement. The core also includes 16 Kbytes of L1 instruction and data caches and on-chip memory management units (MMUs). The MPC8321E also includes a 32-bit PCI controller, four DMA channels, a flexible local bus, and a 32-bit DDR-1/DDR-2 SDRAM memory controller..

QUICC Engine™ Technology A new single-RISC version of the QUICC Engine™ communications engine forms the heart of the networking capability of the MPC8321E. The QUICC Engine® block contains several peripheral controllers and a single 32-bit reduced instruction set computing (RISC) controller. Unique microcode packages provide support for NAT, Firewall, IPSec, and Advanced Quality of Service (QoS). Protocol support is provided by the main workhorses of the device - the unified communication controllers (UCCs). Each of the five UCCs can support a variety of communication protocols:

- Up to (3) 10/100 Mbps Ethernet
- High-level data link control (HDLC)
- Up to (4) Time division multiplexing (TDM)
- Binary synchronous communications protocol (BISYNC)
- UCC can also support USB 2.0 (full/low speed)

Hardware Security Engine The security engine (SEC 2.2) on the MPC8321E allows CPU-intensive cryptographic operations to be off-loaded from the main CPU core. The security-processing accelerator provides hardware acceleration for DES, 3DES, Advanced Encryption Standard (AES), Secure Hash Algorithm (SHA)-1 and MD-5 algorithms.

System Interface Unit The MPC8321E family also includes a 32-bit double data rate (DDR)-1/DDR/2 memory controller, a 32-bit peripheral component interconnect (PCI) controller, a 16-bit local bus and four direct memory access (DMA) channels.

Typical Applications

- Residential gateways
- SOHO networking
- VPN routers
- Access points
- DSLAM line cards
- Industrial control
- Test and measurement equipment

MPC8321E Block Diagram Block Diagram

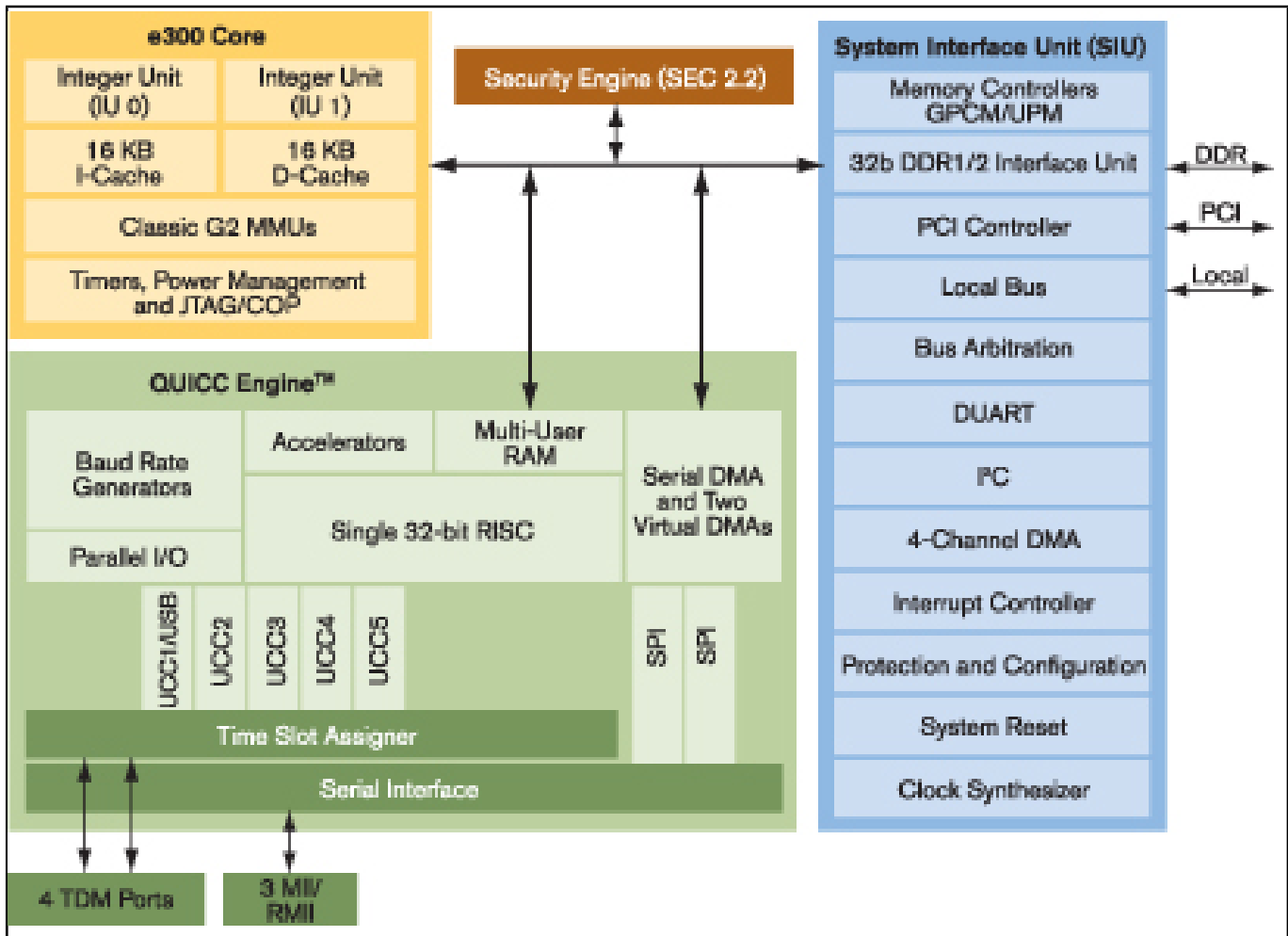

View additional information for [Low-Power PowerQUICC® II Pro Processor with DDR2, TDM, PCI, Security, USB, QUICC Engine®](#).

Note: The information on this document is subject to change without notice.

www.nxp.com

NXP and the NXP logo are trademarks of NXP B.V. All other product or service names are the property of their respective owners. The related technology may be protected by any or all of patents, copyrights, designs and trade secrets. All rights reserved. © 2024 NXP B.V.