



MPC5643L 3-phase PMSM Development Kit

MTRCKTSPS5643L

Last Updated: Aug 22, 2023

The NXP® MTRCKTSPS5643L motor control development kit is ideal for applications requiring one PMSM motor, such as active suspension or electric powertrain.

- Designed to enable rapid prototyping and evaluation of the motor control application without having to wait for the final hardware design.
- Includes a 32-bit NXP MPC5643L based controller board and the 3-phase low-voltage power stage board.
- Application software that provides a complete reference implementation of the PMSM motor control application and takes advantage of the Automotive Math and Motor Control Library Set.

MTRCKTSPS5643L NXP MPC5643L Single 3-phase PMSM Kit Block Diagram

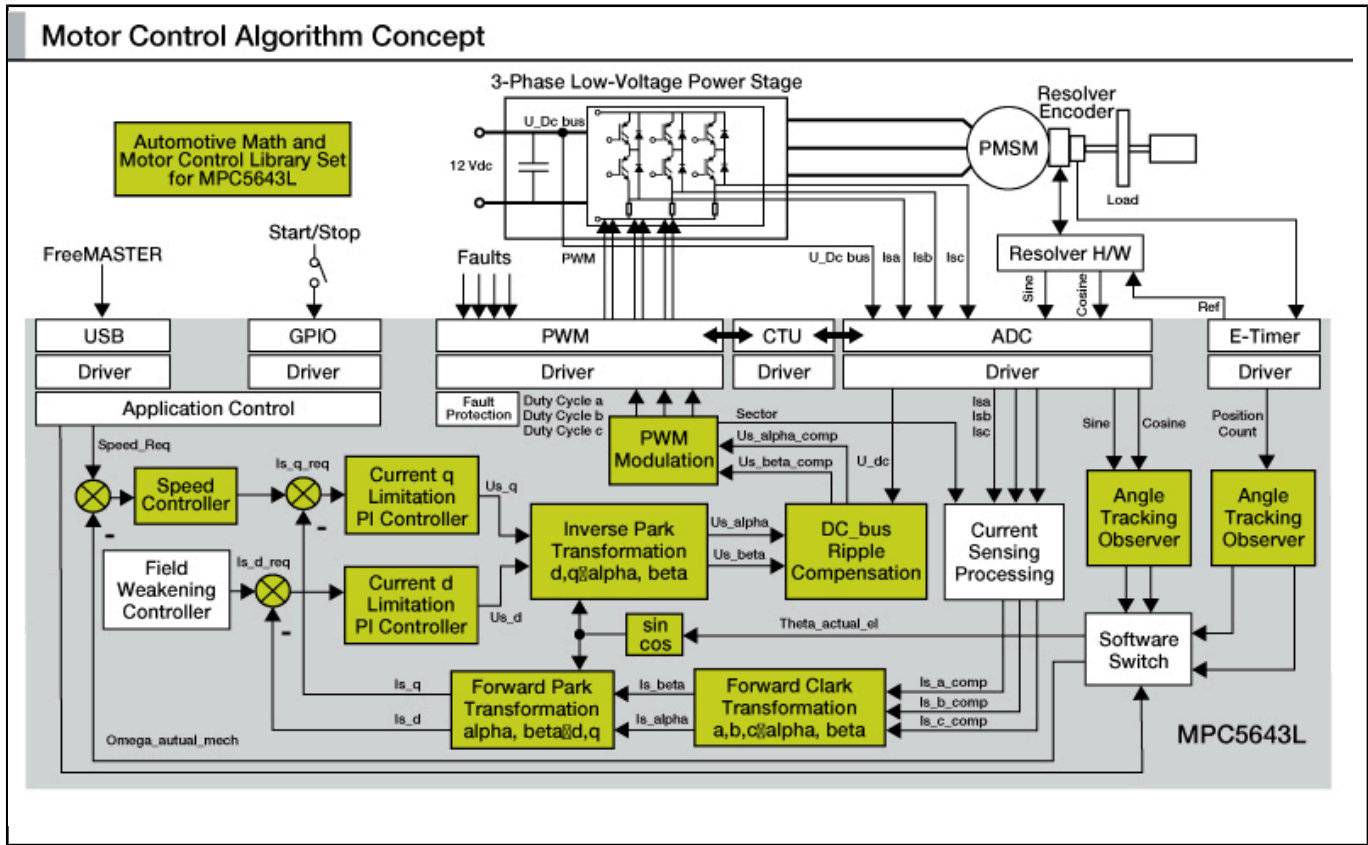

MTRCKTSPS5643L NXP MPC5643L Single 3-Phase PMSM Kit Block Diagram

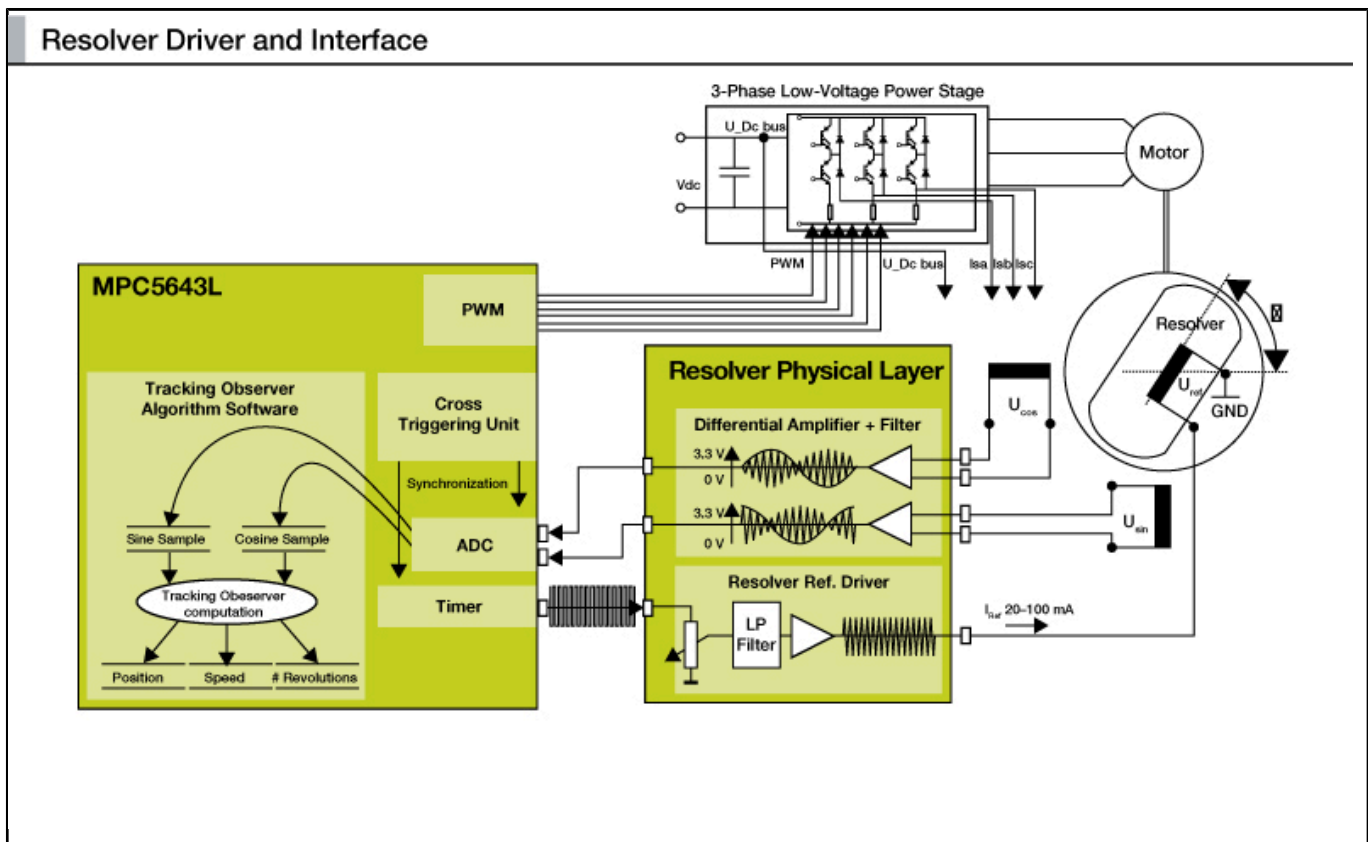

View additional information for [MPC5643L 3-phase PMSM Development Kit](#).

Note: The information on this document is subject to change without notice.

www.nxp.com

NXP and the NXP logo are trademarks of NXP B.V. All other product or service names are the property of their respective owners. The related technology may be protected by any or all of patents, copyrights, designs and trade secrets. All rights reserved. © 2023 NXP B.V.