



Dual High-Speed USB 2.0 Double-Pole Double-Throw Analog Switch

NX3DV42

Last Updated: Sep 21, 2022

The NX3DV42 is a double-pole double-throw analog switch suitable for use as an analog or digital multiplexer/demultiplexer. Its wide bandwidth and low bit-to-bit skew allows the NX3DV42 to pass high-speed differential signals with good signal integrity. Its high channel to channel crosstalk rejection results in minimal noise interference. The bandwidth is wide enough to pass high-speed USB 2.0 differential signals (480 Mb/s). It consists of two switches, each with two independent input/outputs (HSDn+ and HSDn-) and a common input/output (D+ or D-). One digital input (S) is used to select the switch position. When pin OE is HIGH, the switches are turned off. Schmitt trigger action at the select input (S) and enable input (OE) makes the circuit tolerant to slower input rise and fall times across the entire VCC range from 3.0 V to 4.3 V.

NX3DV42 Block Diagram Block Diagram

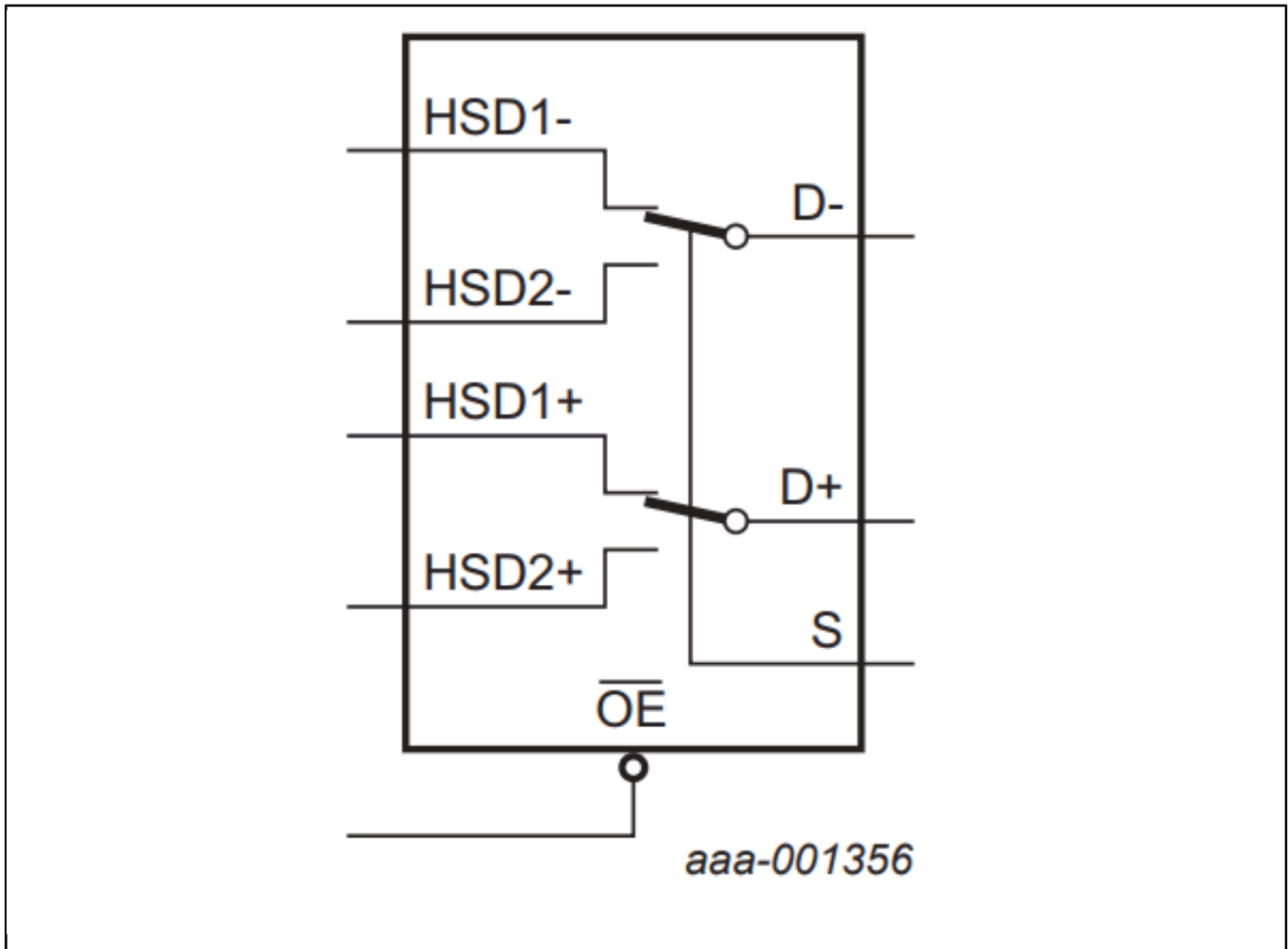

View additional information for [Dual High-Speed USB 2.0 Double-Pole Double-Throw Analog Switch](#).

Note: The information on this document is subject to change without notice.

www.nxp.com

NXP and the NXP logo are trademarks of NXP B.V. All other product or service names are the property of their respective owners. The related technology may be protected by any or all of patents, copyrights, designs and trade secrets. All rights reserved. © 2022 NXP B.V.