



Single Low-Ohmic 8-Channel Analog Switch

NX3L4051

Last Updated: Apr 8, 2022

The NX3L4051 is a low-ohmic 8-channel analog switch, suitable for use as an analog or digital multiplexer/demultiplexer. The NX3L4051 has three digital select inputs (S1 to S3), eight independent inputs/outputs (Y0 to Y7) and a common input/output (Z). All eight switches share an enable input (E). A HIGH on E causes all switches into the high impedance OFF-state, independent of Sn.

Schmitt trigger action at the digital inputs makes the circuit tolerant to slower input rise and fall times. Low threshold digital inputs allows this device to be driven by 1.8 V logic levels in 3.3 V applications without significant increase in supply current ICC. This makes it possible for the NX3L4051 to switch 4.3 V signals with a 1.8 V digital controller, eliminating the need for logic level translation. The NX3L4051 allows signals with amplitude up to VCC to be transmitted from Z to Yn or from Yn to Z. Its low ON resistance (0.5 Ω) and flatness (0.13 Ω) ensures minimal attenuation and distortion of transmitted signals.

NX3L4051, Q100 Block Diagram Block Diagram

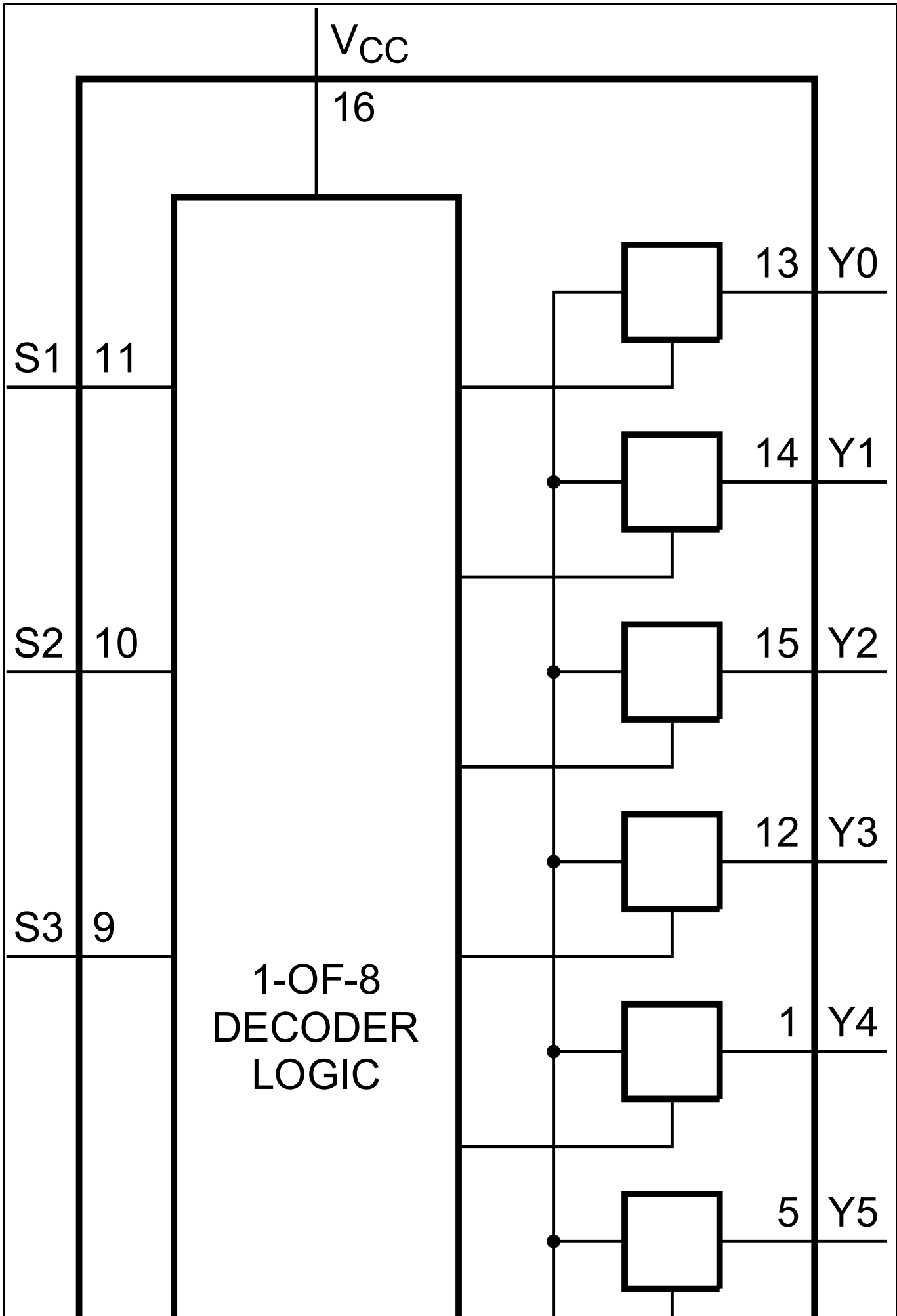

View additional information for [Single Low-Ohmic 8-Channel Analog Switch](#).

Note: The information on this document is subject to change without notice.

www.nxp.com

NXP and the NXP logo are trademarks of NXP B.V. All other product or service names are the property of their respective owners. The related technology may be protected by any or all of patents, copyrights, designs and trade secrets. All rights reserved. © 2022 NXP B.V.