



80C51 8–Bit Microcontroller Family

P87C660X2FA

Last Updated: Mar 8, 2023

The devices are Single-Chip 8-Bit Microcontrollers manufactured in an advanced CMOS process and are derivatives of the 80C51 microcontroller family. The instruction set is 100pct compatible with the 80C51 instruction set.

The devices support 6-clock/12-clock mode selection by programming an OTP bit (OX2) using parallel programming. In addition, an SFR bit (X2) in the clock control register (CKCON) also selects between 6-clock/12-clock mode.

These devices have either one or two I²C interfaces, capable of handling speeds up to 400 kbits/s (Fast I²C). They also have four 8-bit I/O ports, three 16-bit timer/event counters, a multi-source, four-priority-level, nested interrupt structure, an enhanced UART and on-chip oscillator and timing circuits.

The added features of the P8xC66xX2 make it a powerful microcontroller for applications that require pulse width modulation, high-speed I/O, I²C communication, and up/down counting capabilities such as motor control.

Block diagram: P87C51RA2BA, P87C51RA2FA, P87C51RB2BA, P87C51RB2BBD, P87C51RB2BN Block Diagram

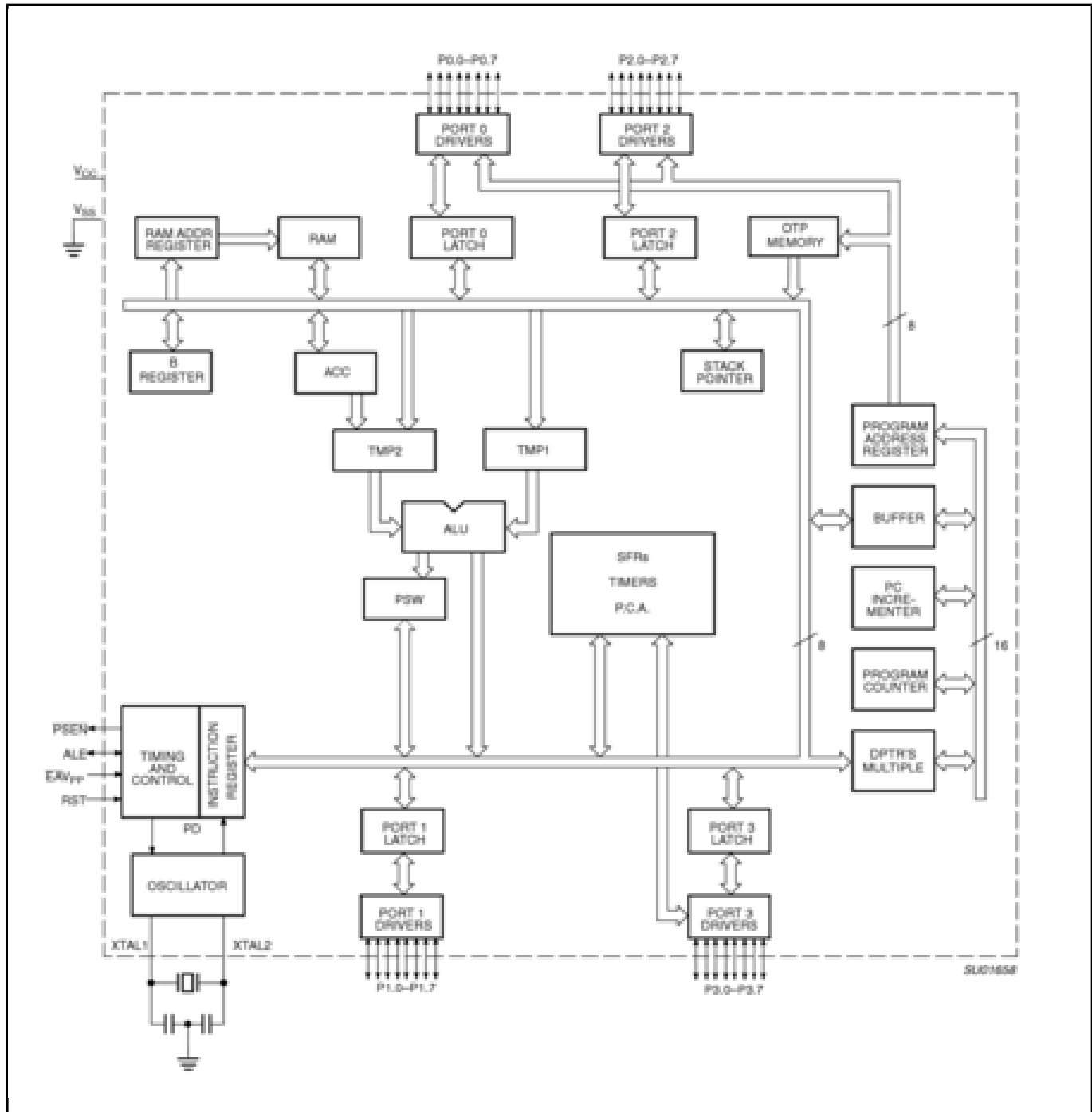

View additional information for [80C51 8-Bit Microcontroller Family](#).

Note: The information on this document is subject to change without notice.

www.nxp.com

NXP and the NXP logo are trademarks of NXP B.V. All other product or service names are the property of their respective owners. The related technology may be protected by any or all of patents, copyrights, designs and trade secrets. All rights reserved. © 2024 NXP B.V.