



# Automotive Low-Powered RTC IC

PCA85074ADP **NEW**

## Preproduction

This page contains information on a preproduction product. Specifications and information herein are subject to change without notice. For additional information please contact your sales representative.

Last Updated: Jun 25, 2026

The PCA85074ATL is a low-power, Automotive-grade real-time clock (RTC) IC designed for reliable timekeeping, supporting high-temperature operation up to 125 °C.

## PCA85074ADP Internal Block Diagram

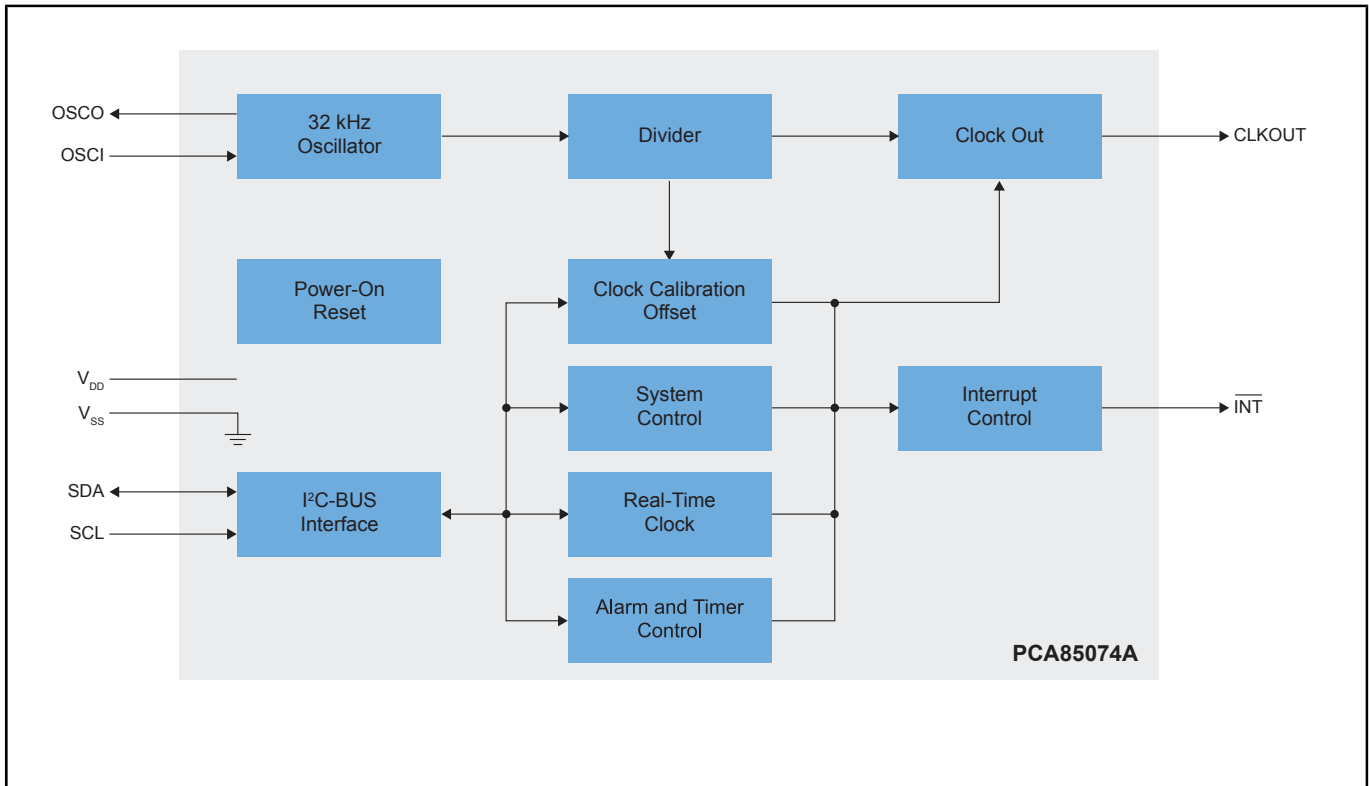

View additional information for [Automotive Low-Powered RTC IC](#).

**Note:** The information on this document is subject to change without notice.

**www.nxp.com**

NXP and the NXP logo are trademarks of NXP B.V. All other product or service names are the property of their respective owners. The related technology may be protected by any or all of patents, copyrights, designs and trade secrets. All rights reserved. © 2026 NXP B.V.