



4-Bit Multiplexed/1-Bit Latched 5-Bit I²C EEPROM DIP Switch

PCA8550

Last Updated: Mar 23, 2023

The primary function of the 4-bit 2-to-1 I²C multiplexer is to select either a 4-bit input or data from a non-volatile register and drive this value onto the output pins. One additional non-multiplexed register output is also provided. The non-multiplexed output is latched to prevent output value changes during I²C writes to the non-volatile register. A write protect input is provided to enable/disable the ability to write to the non-volatile register. An "override" input feature forces all outputs to logic 0.

PCA8550 Block Diagram Block Diagram

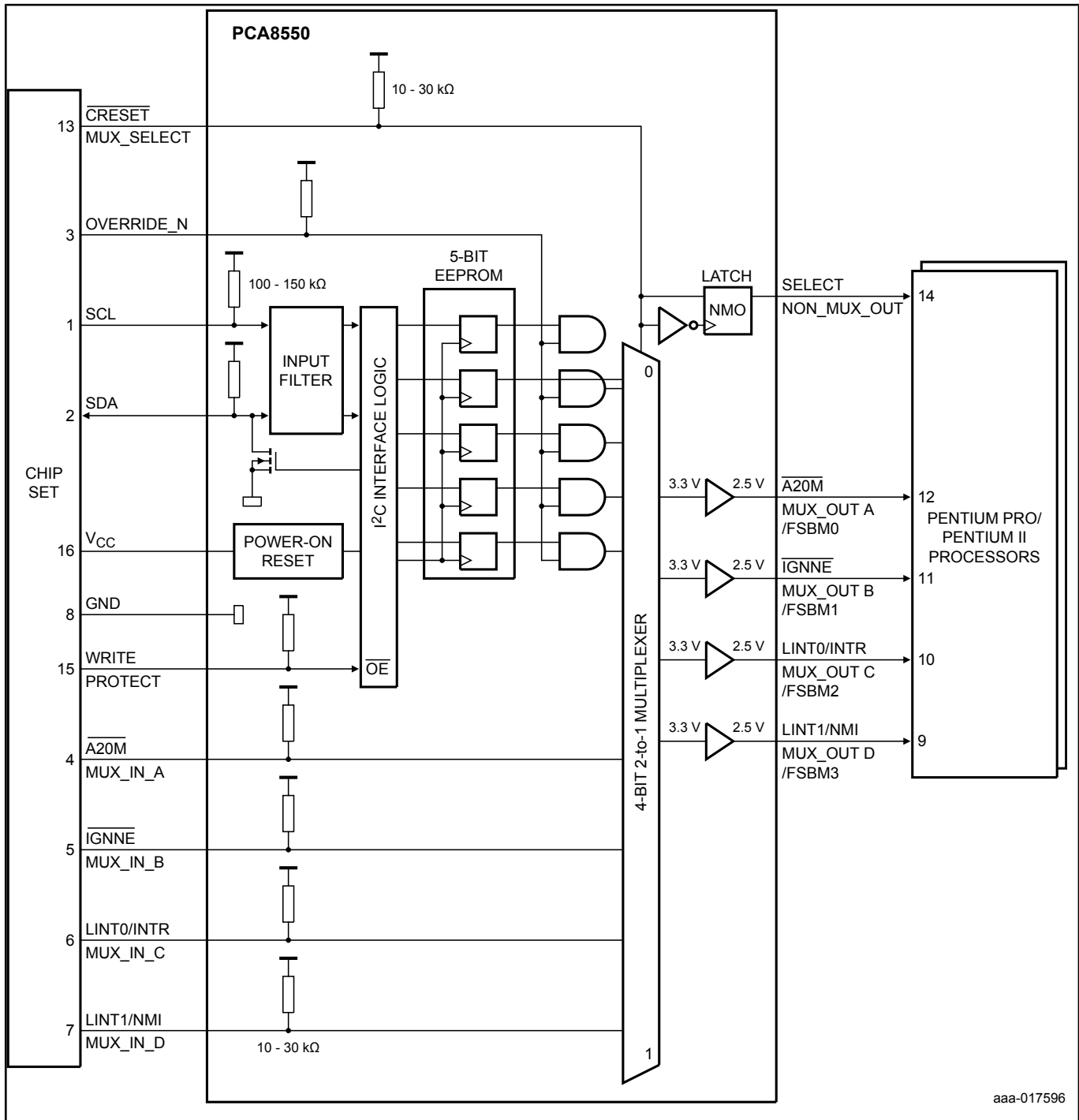

View additional information for [4-Bit Multiplexed/1-Bit Latched 5-Bit I²C EEPROM DIP Switch](#).

Note: The information on this document is subject to change without notice.

www.nxp.com

NXP and the NXP logo are trademarks of NXP B.V. All other product or service names are the property of their respective owners. The related technology may be protected by any or all of patents, copyrights, designs and trade secrets. All rights reserved. © 2023 NXP B.V.