



Two-Wire Serial Bus Extender for HDMI DDC I²C-Bus and SMBus

PCA9507

Last Updated: Jun 13, 2022

The PCA9507 is a 2-wire serial bus extender providing 3.3 V to 5 V level shift that allows up to 18 meters bus extension for reliable DDC, I²C-bus or SMBus applications. While retaining all the operating modes and features of the I²C-bus system during the level shifts, it also permits extension of the I²C-bus by providing bidirectional buffering for both the data (SDA) and the clock (SCL) line as well as the rise time accelerator on port A enabling the bus to drive a load up to 1400 pF or distance of 18 m on port A, and 400 pF on port B. Using the PCA9507 enables the system designer to isolate bus capacitance to meet HDMI DDC version 1.3 distance specification. The SDA and SCL pins are overvoltage tolerant and are high-impedance when the PCA9507 is unpowered.

The port B drivers with static level offset behave much like the drivers on the PCA9515 device, while the port A drivers integrate the rise time accelerator, sink more current and eliminate the static offset voltage. This results in a LOW on port B translating into a nearly 0 V LOW on port A. The static level offset design of the port B I/O drivers prevent them from being connected to another device that has rise time accelerator including the PCA9510, PCA9511, PCA9512, PCA9513, PCA9514, PCA9515, PCA9516A, PCA9517 (B-side), or PCA9518. The port A sides of two or more PCA9507s can be connected together, however, to allow a star topography with port A on the common bus, and port A can be connected directly to any other buffer with static or dynamic offset voltage. Multiple PCA9507s can be connected in series, port A to port B, with no build-up in offset voltage with only time of flight delays to consider. Rise time accelerator on port A is turned on when input threshold is above 0.3VCC(A).

The PCA9507 drivers are not enabled unless VCC(A) and VCC(B) are above 2.7 V. The EN pin can also be used to turn the drivers on and off under system control. Caution should be observed to only change the state of the enable pin when the bus is idle. The output pull-down on the port B internal buffer LOW is set for approximately 0.5 V, while the input threshold of the internal buffer is set about 70 mV lower (0.43 V). When the port B I/O is driven LOW internally, the LOW is not recognized as a LOW by the input. This prevents a lock-up condition from occurring.

PCA9507 Block Diagram Block Diagram

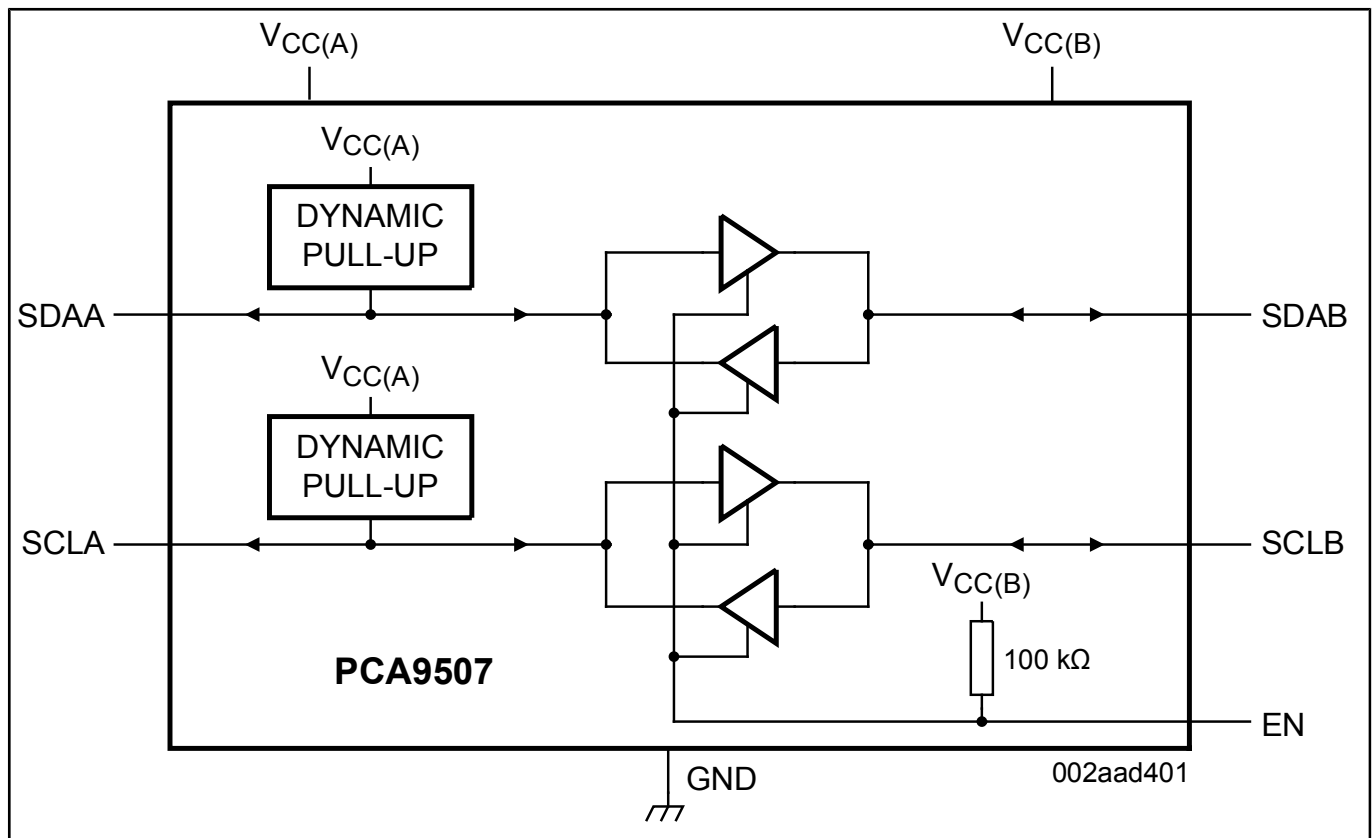

View additional information for [Two-Wire Serial Bus Extender for HDMI DDC I²C-Bus and SMBus](#).

Note: The information on this document is subject to change without notice.

www.nxp.com

NXP and the NXP logo are trademarks of NXP B.V. All other product or service names are the property of their respective owners. The related technology may be protected by any or all of patents, copyrights, designs and trade secrets. All rights reserved. © 2022 NXP B.V.