



# 4-Bit I<sup>2</sup>C-Bus LED Dimmer

## PCA9533

Last Updated: Sep 5, 2022

The PCA9533 is a 4-bit I<sup>2</sup>C-bus and SMBus I/O expander optimized for dimming LEDs in 256 discrete steps for Red/Green/Blue (RGB) color mixing and backlight applications.

The PCA9533 contains an internal oscillator with two user programmable blink rates and duty cycles coupled to the output PWM. The LED brightness is controlled by setting the blink rate high enough (> 100 Hz) that the blinking cannot be seen and then using the duty cycle to vary the amount of time the LED is on and thus the average current through the LED.

The initial setup sequence programs the two blink rates/duty cycles for each individual PWM. From then on, only one command from the bus controller is required to turn individual LEDs ON, OFF, BLINK RATE 1 or BLINK RATE 2. Based on the programmed frequency and duty cycle, BLINK RATE 1 and BLINK RATE 2 will cause the LEDs to appear at a different brightness or blink at periods up to 1.69 seconds. The open-drain outputs directly drive the LEDs with maximum output sink current of 25 mA per bit and 100 mA per package.

To blink LEDs at periods greater than 1.69 second the bus controller (MCU, MPU, DSP, chipset, etc.) must send repeated commands to turn the LED on and off as is currently done when using normal I/O expanders like the NXP Semiconductors PCF8574 or PCA9554. Any bits not used for controlling the LEDs can be used for General Purpose parallel Input/Output (GPIO) expansion, which provides a simple solution when additional I/O is needed for ACPI power switches, sensors, push-buttons, alarm monitoring, fans, etc.

The Power-On Reset (POR) initializes the registers to their default state, causing the bits to be set HIGH (LED off).

Due to pin limitations, the PCA9533 is not featured with hardware address pins. The PCA9533/01 and the PCA9533/02 have different fixed I<sup>2</sup>C-bus addresses allowing operation of both on the same bus.

## PCA9533 Block Diagram Block Diagram

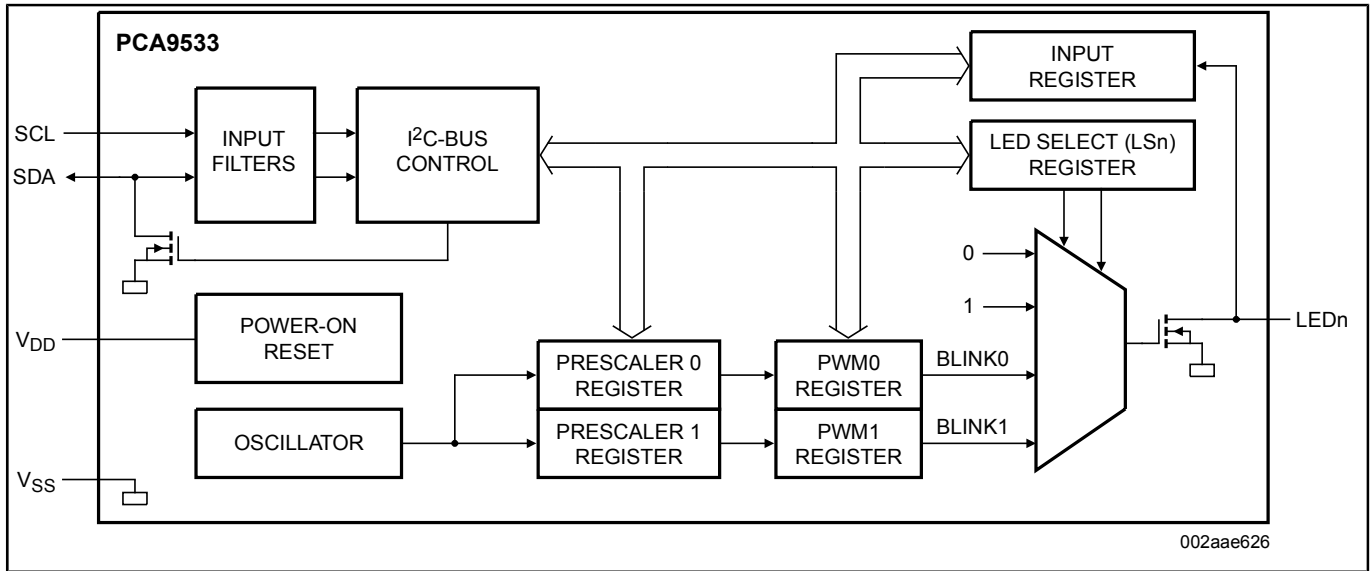

## Block diagram: PCA9533D, PCA9533DP Block Diagram

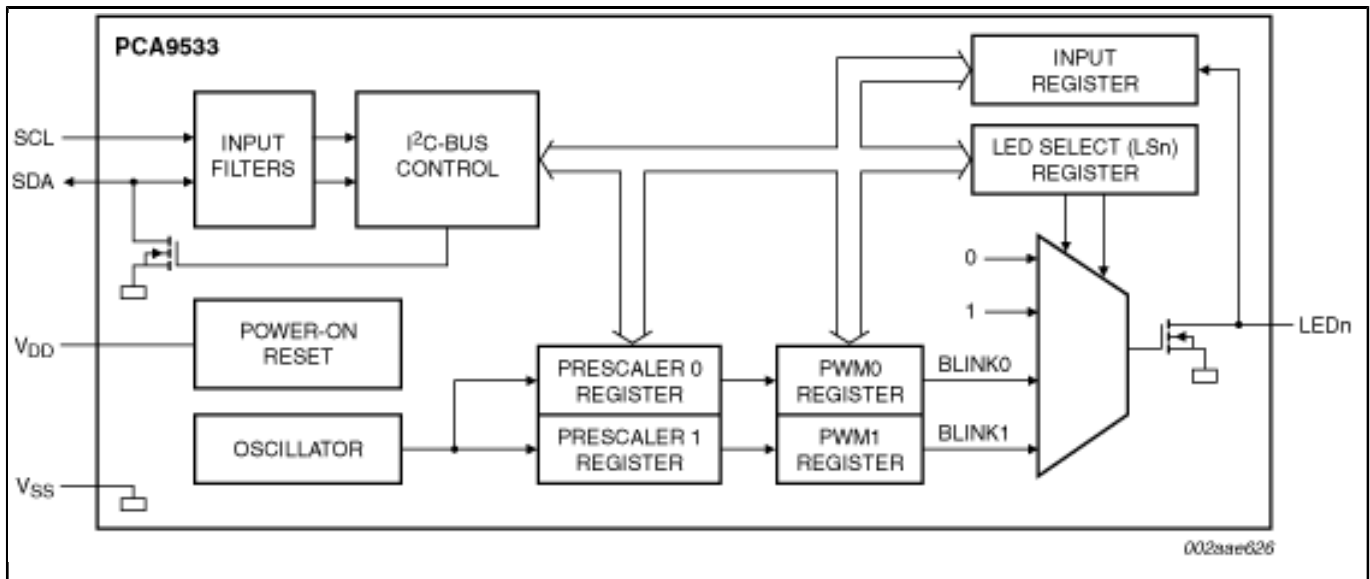

View additional information for [4-Bit I<sup>2</sup>C-Bus LED Dimmer](#).

Note: The information on this document is subject to change without notice.

[www.nxp.com](http://www.nxp.com)

NXP and the NXP logo are trademarks of NXP B.V. All other product or service names are the property of their respective owners. The related technology may be protected by any or all of patents, copyrights, designs and trade secrets. All rights reserved. © 2024 NXP B.V.