



# Low-Voltage 16-Bit I<sup>2</sup>C-Bus I/O Port with Interrupt and Weak Pull-Up

## PCA9555A

Last Updated: Feb 13, 2023

The PCA9555A is a low-voltage 16-bit General Purpose Input/Output (GPIO) expander with interrupt and weak pull-up resistors for I<sup>2</sup>C-bus/SMBus applications. NXP I/O expanders provide a simple solution when additional I/Os are needed while keeping interconnections to a minimum, for example, in ACPI power switches, sensors, push buttons, LEDs, fan control, etc.

In addition to providing a flexible set of GPIOs, the wide VDD range of 1.65 V to 5.5 V allows the PCA9555A to interface with next-generation microprocessors and microcontrollers where supply levels are dropping down to conserve power.

The PCA9555A contains the PCA9555 register set of four pairs of 8-bit Configuration, Input, Output, and Polarity Inversion registers.

The PCA9555A is a pin-to-pin replacement to the PCA9555 and other industry-standard devices. A more fully featured device, the PCAL9555A, is available with Agile I/O features. See the respective data sheet for more details.

The PCA9555A open-drain interrupt (INT) output is activated when any input state differs from its corresponding Input Port register state and is used to indicate to the system controller that an input state has changed.

INT can be connected to the interrupt input of a microcontroller. By sending an interrupt signal on this line, the remote I/O can inform the microcontroller if there is incoming data on its ports without having to communicate via the I<sup>2</sup>C-bus. Thus, the PCA9555A can remain a simple target device.

The device outputs have 25 mA sink capabilities for directly driving LEDs while consuming low device current.

The power-on reset sets the registers to their default values and initializes the device state machine.

All input/output pins have weak pull-up resistors connected to them to eliminate external components.

Three hardware pins (A0, A1, A2) select the fixed I<sup>2</sup>C-bus address and allow up to eight devices to share the same I<sup>2</sup>C-bus/SMBus.

### PCA9555A Block Diagram Block Diagram

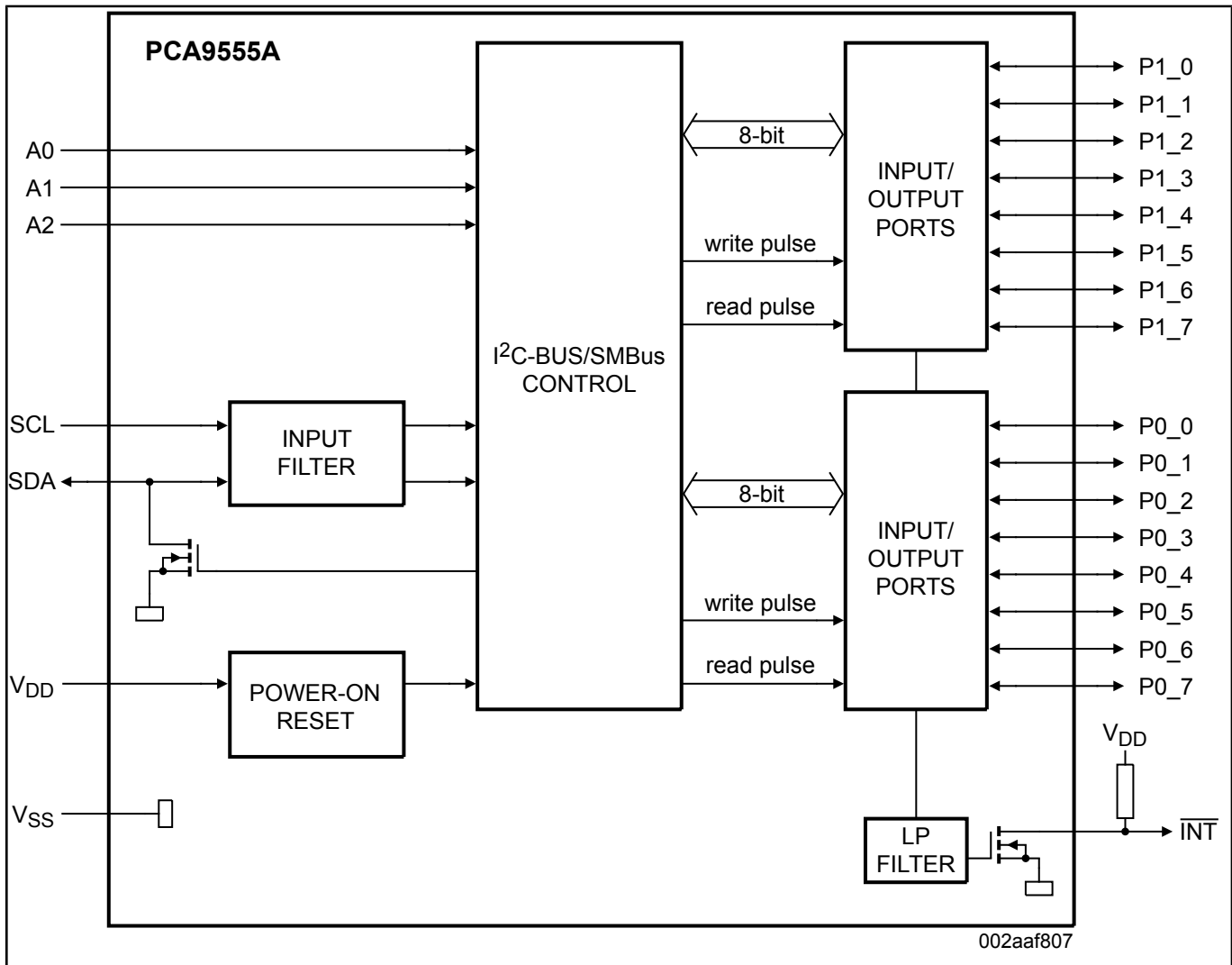

**Note:** The information on this document is subject to change without notice.

---

**[www.nxp.com](http://www.nxp.com)**

NXP and the NXP logo are trademarks of NXP B.V. All other product or service names are the property of their respective owners. The related technology may be protected by any or all of patents, copyrights, designs and trade secrets. All rights reserved. © 2024 NXP B.V.