



5-Bit Multiplexed/1-Bit Latched 6-Bit I²C EEPROM DIP Switch

PCA9559PW

Last Updated: Feb 13, 2023

The PCA9559 is a 20-pin CMOS device consisting of one 6-bit non-volatile EEPROM registers, 5 hardware pin inputs and a 5-bit multiplexed output with one latched EEPROM bit. It is used for DIP switch-free or jumper-less system configuration and supports Mobile and Desktop VID Configuration, where 2 preset values (1 set of internal non-volatile registers and 1 set of external hardware pins) set processor voltage for operation in either performance or deep sleep modes. The PCA9559 is also useful in server and telecom/networking applications when used to replace DIP switches or jumpers, since the settings can be easily changed via I²C/SMBus without having to power down the equipment to open the cabinet. The non-volatile memory retains the most current setting selected before the power is turned off.

The PCA9559 typically resides between the CPU and Voltage Regulator Module (VRM) when used for CPU VID (Voltage IDentification code) configuration. It is used to bypass the CPU-defined VID values and provide a different set of VID values the VRM, if an increase in the CPU voltage is desired. An increase in CPU voltage combined with an increase in CPU frequency leads to a performance boost of up to 7.5pct. Lower CPU voltage reduces power consumption.

The PCA9559 has 2 address pins allowing up to 4 devices to be placed on the same I²C-bus or SMBus.

PCA9559 Block Diagram Block Diagram

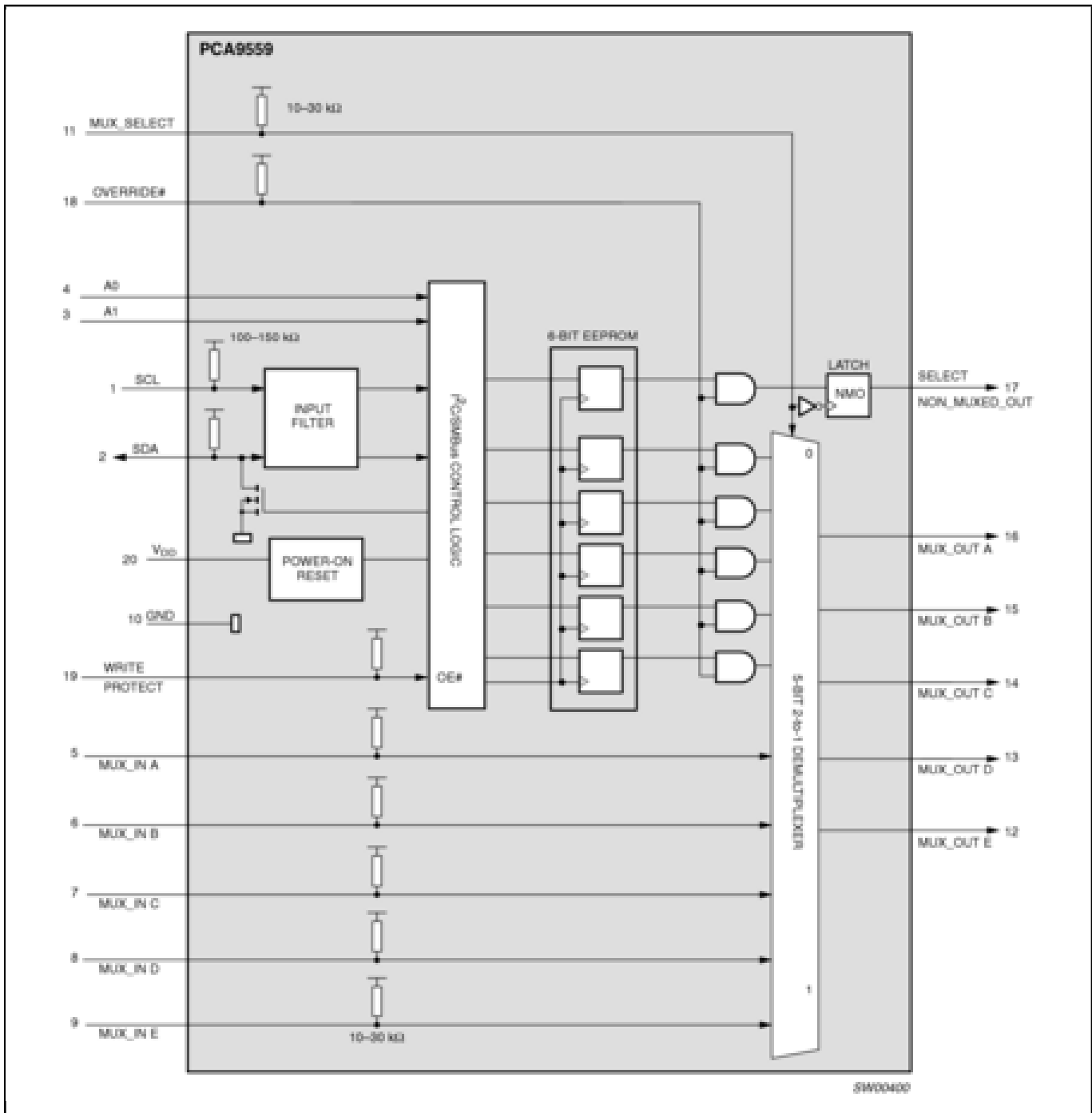

View additional information for [5-Bit Multiplexed/1-Bit Latched 6-Bit I²C EEPROM DIP Switch](#).

Note: The information on this document is subject to change without notice.

www.nxp.com

NXP and the NXP logo are trademarks of NXP B.V. All other product or service names are the property of their respective owners. The related technology may be protected by any or all of patents, copyrights, designs and trade secrets. All rights reserved. © 2023 NXP B.V.