



# 8-Channel Constant Current LED Driver with Output Error Detection

## PCA9922

Last Updated: Sep 5, 2022

The PCA9922 is an 8-channel constant current LED driver designed for LED signage and display applications. The output current is adjustable from 15 mA to 60 mA controlled by an external series resistor. The outputs are controlled via a serial interface with a maximum clock frequency of 25 MHz to allow for the system requirement of high volume data transmission. Each of the 8 channel outputs has edge rate control to limit the change in current when the outputs are enabled or disabled.

The device has built-in circuitry for detecting LED open-circuit and output short to ground. After signaling the specified error detect sequence on the input control lines, error status can be read out of the device via the serial data out.

The device is designed such that it may be cascaded with other similar devices. The SDO pin contains the output of the shift register which may be used for cascading to the SDI pin of the next device in the series. SDO changes state on the falling edge of CLK. SDI captures data on the rising edge of CLK.

The PCA9922 is a pin-to-pin functionally equivalent 5 V alternative for the ST2221A and STP08CDC596.

The PCA9922 is available in DIP16, TSSOP16 and HVQFN20 packages and is specified over the -40 # to +85 # industrial temperature range.

### Block diagram: PCA9922BS, PCA9922N, PCA9922PW Block Diagram

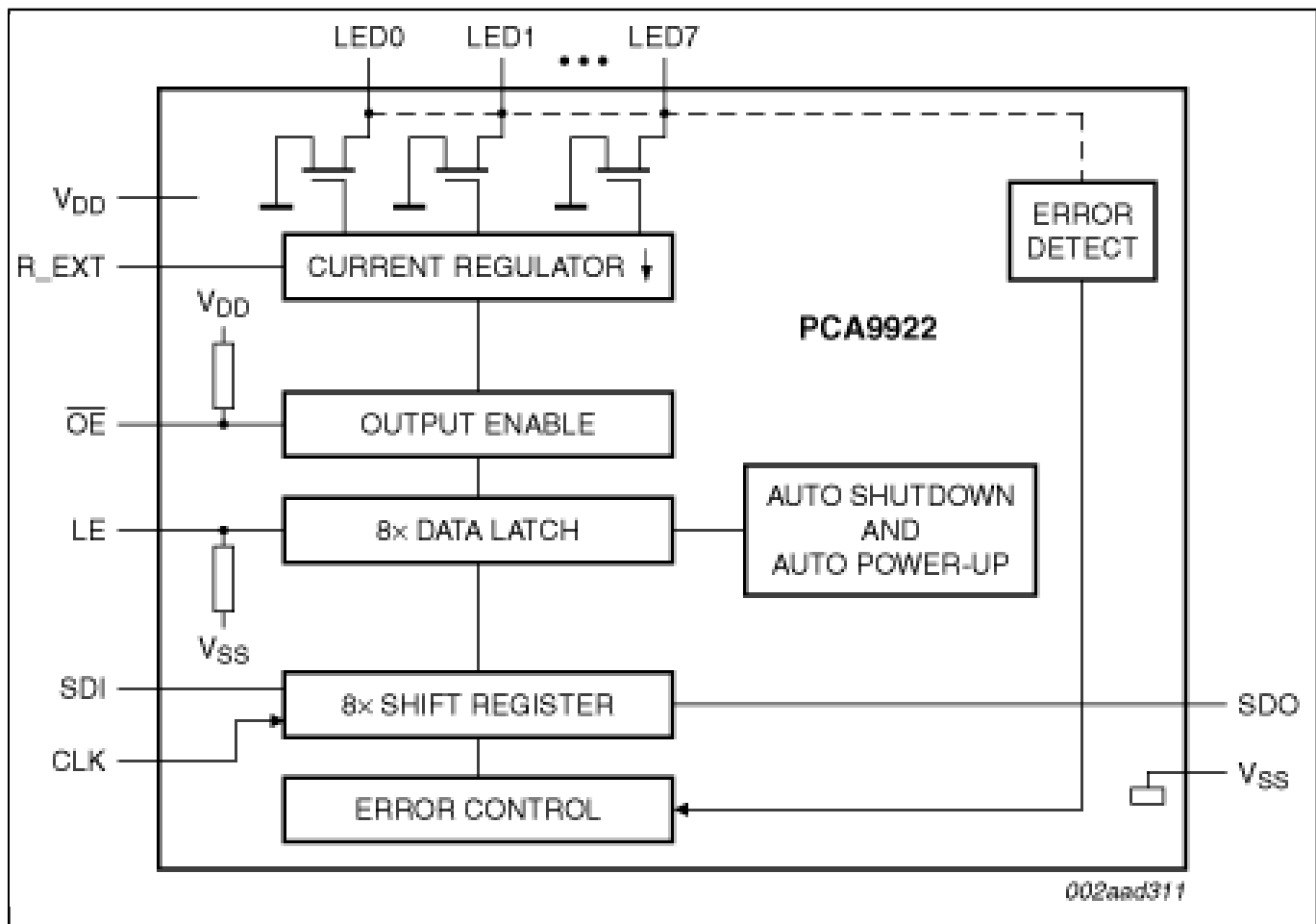

View additional information for [8-Channel Constant Current LED Driver with Output Error Detection](#).

**Note:** The information on this document is subject to change without notice.

[www.nxp.com](http://www.nxp.com)

NXP and the NXP logo are trademarks of NXP B.V. All other product or service names are the property of their respective owners. The related technology may be protected by any or all of patents, copyrights, designs and trade secrets. All rights reserved. © 2022 NXP B.V.