



LCD Row/Column Driver for Dot Matrix Graphic Displays

PCF8578

Not Recommended for New Designs

This page contains information on a product that is not recommended for new designs.

Last Updated: Aug 7, 2023

The PCF8578 is a low power CMOS LCD row and column driver, designed to drive dot matrix graphic displays at multiplex rates of 1:8, 1:16, 1:24 or 1:32. The device has 40 outputs, of which 24 are programmable and configurable for the following ratios of rows/columns: 32/8, 24/16, 16/24 or 8/32. The PCF8578 can function as a stand-alone LCD controller and driver for use in small systems. For larger systems it can be used in conjunction with up to 32 PCF8579s for which it has been optimized. Together these two devices form a general purpose LCD dot matrix driver chip set, capable of driving displays of up to 40960 dots. The PCF8578 is compatible with most microcontrollers and communicates via a two-line bidirectional bus (I²C-bus). Communication overhead is minimized by a display RAM with auto-incremented addressing and display bank switching.

Block diagram: PCF8578HT, PCF8578T Block Diagram

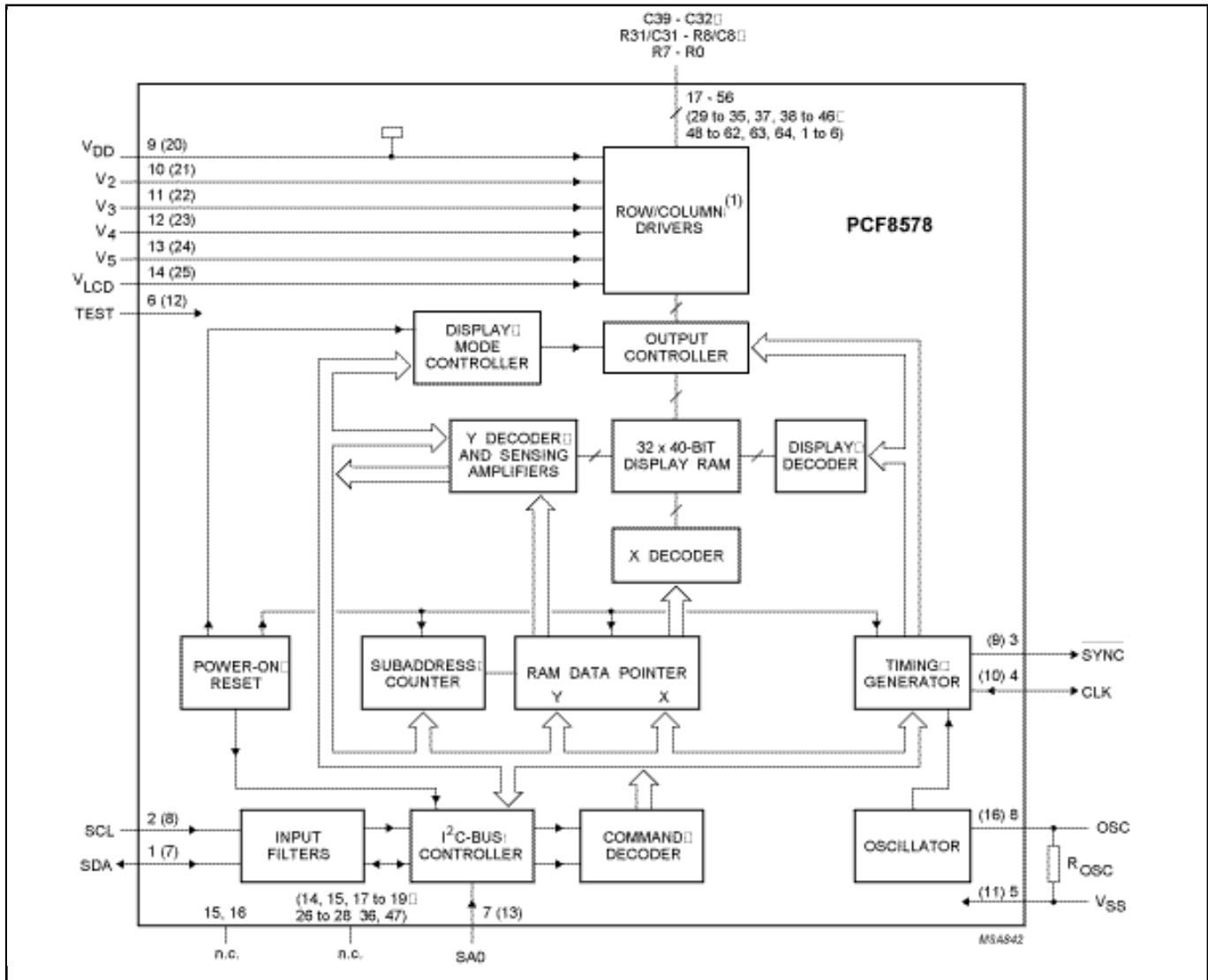

View additional information for [LCD Row/Column Driver for Dot Matrix Graphic Displays](#).

Note: The information on this document is subject to change without notice.

www.nxp.com

NXP and the NXP logo are trademarks of NXP B.V. All other product or service names are the property of their respective owners. The related technology may be protected by any or all of patents, copyrights, designs and trade secrets. All rights reserved. © 2023 NXP B.V.