



USB PD TCPC PHY IC

PTN5110

Last Updated: Apr 1, 2026

PTN5110 is a single-port TCPC-compliant USB Power Delivery (PD) PHY IC that implements Type-C Configuration Channel (CC) interface and USB PD Physical layer functions to a Type-C Port Manager (TCPM) that handles PD Policy management. It is designed to comply with USB PD, Type-C, and TCPC specifications. This IC is targeted primarily for use in system platforms (e.g. Notebook PCs, Desktop PCs, Chromebooks, Tablets, Convertibles, etc.). Other use cases may be feasible depending on the application architecture, e.g. docks, monitors, accessories, cable adapters, smartphones etc.

It can support various Type-C roles: Sink, Source, Sink with accessory support or DRP. It implements Type-C CC analog portion (i.e Rd/Rp/Ra detection, Rd/Rp indication) and PD Tx/Rx PHY and protocol state machines. PTN5110 supports TCPM in system realization of the following PD roles:

Provider (P) Provider/Consumer (P/C) Consumer (C) Consumer/Provider (C/P)

PTN5110 integrates VCONN load switch with programmable current limit, reverse leakage current blocking, and OverTemperature Protection (OTP). It implements two enable control outputs for controlling load switches/FETs on VBUS source and/or sink power paths. It also implements VBUS voltage monitoring/measurement, VBUS Force discharge and Bleeds discharge features.

PTN5110 provides the majority of relevant IO capability for the host processor/TCPM to easily control and manage the Type-C/PD interface via the TCPC interface:

- VBUS Power path control of source and sink power rails (EN_SRC, EN_SNK1)
- Up to four different follower addresses can be selected based on SLV_ADDR
- ILIM_5V_VBUS that allows TCPM to set two different current limits on VBUS 5 V Load switch
- FRS_EN that allows for arming 5 V SRC load switch for Fast Role Swap (FRS) support
- DBG_ACC that can be used by host TCPM indicate Type-C debug accessory detection

PTN5110 offers tremendous flexibility to platform integrators by supporting a wide range of power supply input voltages. PTN5110 can operate on VBUS to support certain system use cases needing dead battery operation.

PTN5110 is available in HX2QFN16, 2.6 mm x 2.6 mm x 0.35 mm, 0.4 mm pitch.

Remark: PTN5110 provides independently controllable pull-up resistor (R_p) implementations on CC1 and CC2 pins PTN5110 can detect/monitor voltage levels independently on each CC pin

PTN5110 Block Diagram

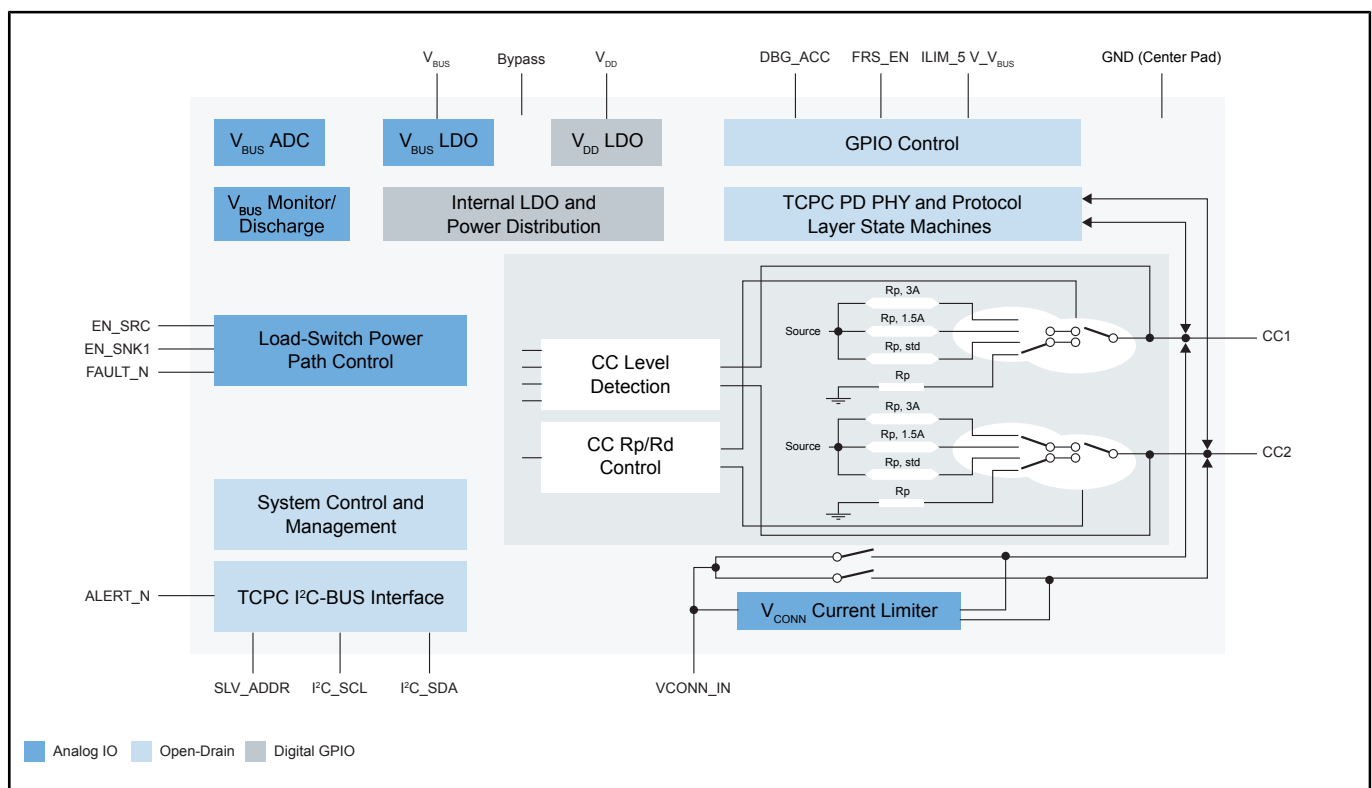

View additional information for [USB PD TCPC PHY IC](#).

Note: The information on this document is subject to change without notice.

www.nxp.com

NXP and the NXP logo are trademarks of NXP B.V. All other product or service names are the property of their respective owners. The related technology may be protected by any or all of patents, copyrights, designs and trade secrets. All rights reserved. © 2026 NXP B.V.