



# MC33775A Evaluation Board with Isolated Daisy Chain Communication

## RD33775ADSTEVB

Last Updated: Aug 9, 2023

The RD33775ADSTEVB evaluation board (EVB) features the MC33775A, a 14-channel battery cell controller for automotive and industrial Li-ion battery applications. It is a reference cell monitoring unit (CMU), designed to support customer development and evaluation.

The board can be connected to NXP 14-cell battery emulator or a customer Li-ion battery module with 4-14 cells in series. It supports cell voltage measurement, passive cell balancing and GPIOs.

# MC33775A Evaluation Board with Isolated ETPL Daisy Chain Communication Block Diagram

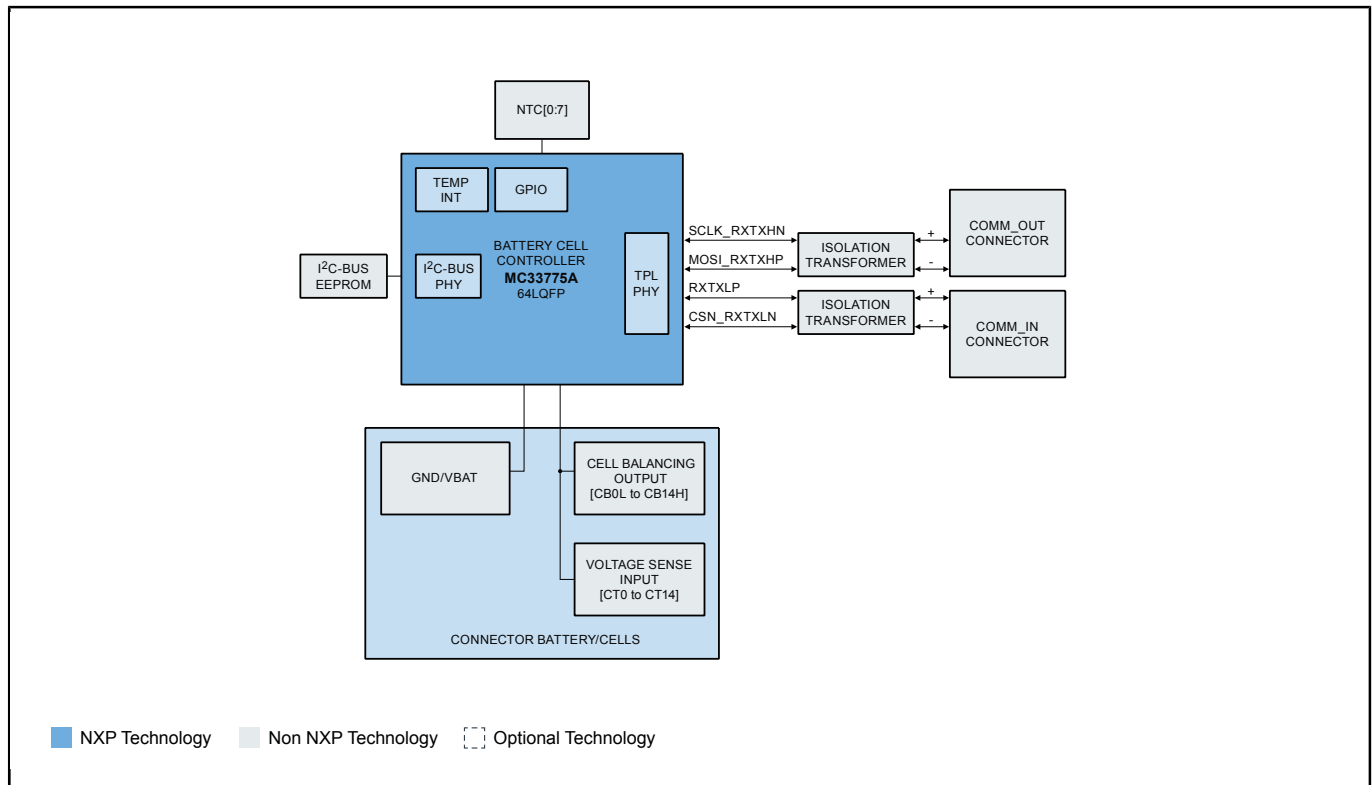

View additional information for [MC33775A Evaluation Board with Isolated Daisy Chain Communication](#).

**Note:** The information on this document is subject to change without notice.

**www.nxp.com**

NXP and the NXP logo are trademarks of NXP B.V. All other product or service names are the property of their respective owners. The related technology may be protected by any or all of patents, copyrights, designs and trade secrets. All rights reserved. © 2024 NXP B.V.