



# 3-Phase Reference Design for Fuji M653 IGBTs Featuring GD3100

## RDGD3100F3PH5EVB

Last Updated: Nov 15, 2022

The RDGD3100F3PH5EVB is a fully functional three-phase power gate drive reference design populated with six [GD3100 gate drivers](#) with fault management and supporting control circuitry.

This board supports SPI daisy chain for programming and communication with three high-side gate drivers and three low-side gate drivers independently. Included is S32SDEV-CON18 PCIe cable for connecting to MCU controller board [MPC5777C-DEVB](#) (not included). This board is designed to be connected to a Fuji Electric M653 Series IGBT module footprint (not included).

# RDGD3100F3PH5EVB Block Diagram

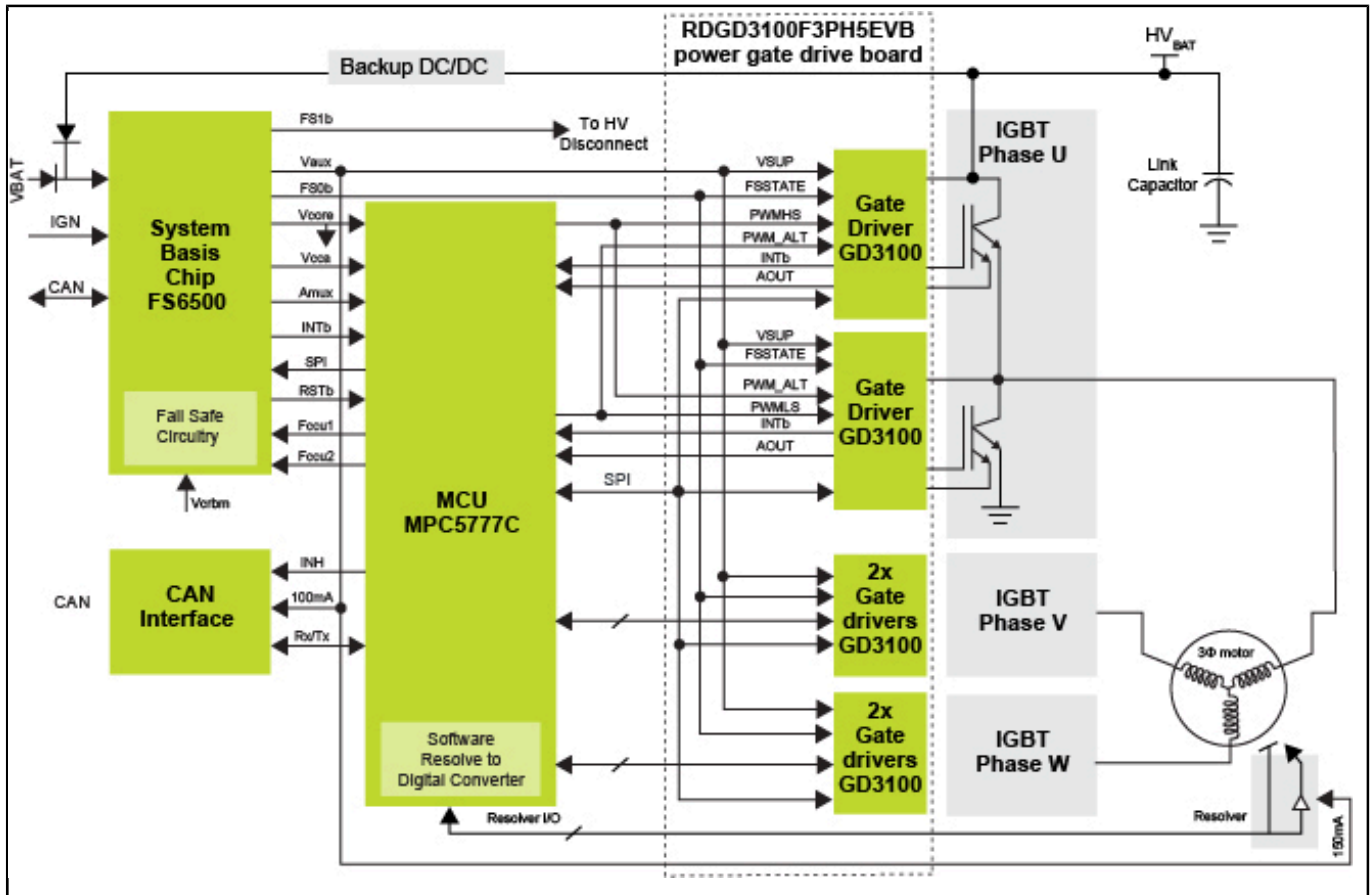

View additional information for [3-Phase Reference Design for Fuji M653 IGBTs Featuring GD3100](#).

Note: The information on this document is subject to change without notice.

[www.nxp.com](http://www.nxp.com)

NXP and the NXP logo are trademarks of NXP B.V. All other product or service names are the property of their respective owners. The related technology may be protected by any or all of patents, copyrights, designs and trade secrets. All rights reserved. © 2023 NXP B.V.