



# One-Chip RFCMOS Automotive Radar SoC for Distributed Architectures

## SAF86XX

### Preproduction

This page contains information on a preproduction product. Specifications and information herein are subject to change without notice. For additional information [contact support](#) or your sales representative.

Last Updated: Mar 7, 2024

The SAF86xx is a highly integrated one-chip RFCMOS radar SoC supporting future distributed automotive radar architectures. The integrated RFCMOS chip contains 4 transmitters, 4 receivers, ADC conversion, phase rotator, low-phase-noise VCO, BBE32EP DSP, Arm® Cortex® – M7 core and SRAM to support various use cases in short-range, medium-range and long-range automotive radar applications. It provides pre-processed radar data, e.g. compressed or uncompressed Range-FFT over Gigabit Ethernet to a radar post-processing unit. SAF86xx is developed in accordance with the functional safety standard ISO 26262 supporting ASIL Level B and ISO/SAE 21434 specifying engineering requirements for cybersecurity risk management. It is meeting the latest security requirements through its HSE security and MACsec engine.

# SAF86xx Radar SoC Block Diagram

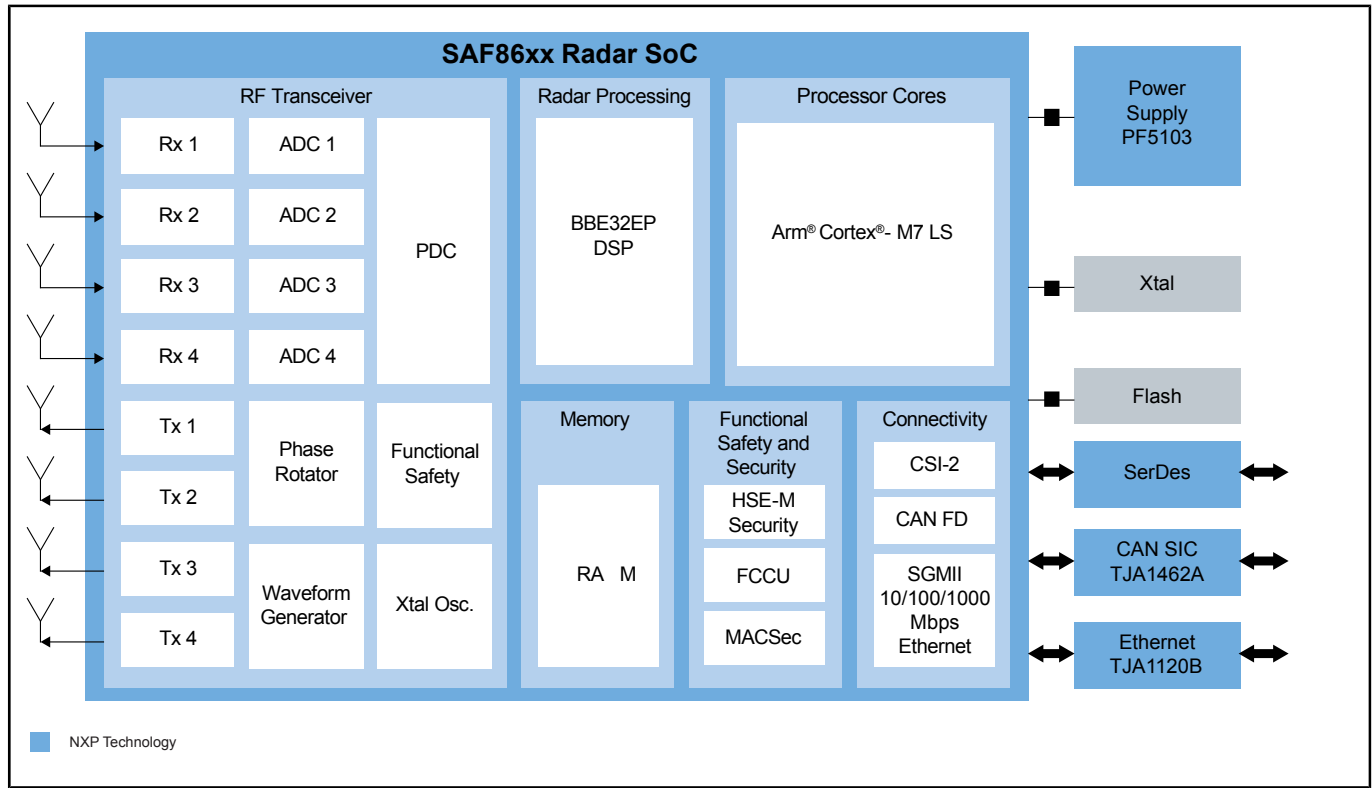

View additional information for [One-Chip RFCMOS Automotive Radar SoC for Distributed Architectures](#).

**Note:** The information on this document is subject to change without notice.

[www.nxp.com](http://www.nxp.com)

NXP and the NXP logo are trademarks of NXP B.V. All other product or service names are the property of their respective owners. The related technology may be protected by any or all of patents, copyrights, designs and trade secrets. All rights reserved. © 2024 NXP B.V.