



NXP EdgeReady MCU-Based Solution for Face Recognition with Liveness Detection

SLN-VIZNLC-IOT

Last Updated: May 15, 2023

NXP's EdgeReady MCU-based solution for face recognition leverages the i.MX RT106F crossover MCU, enabling developers to quickly and easily add face recognition with liveness detection to their products. Liveness detection prevents spoofing with a photograph and is implemented with low cost IR and RGB cameras. The development kit for this solution, SLN-VIZNLC-IOT, comes with fully integrated turnkey software, for quick out-of-the-box operation, minimizing time to market, risk and development effort. Face recognition is done entirely at the edge, addressing the privacy concerns of many consumers. This NXP EdgeReady solution is part of the EdgeVerse™ edge computing platform.

NXP EdgeReady MCU-based Face Recognition Block Diagram

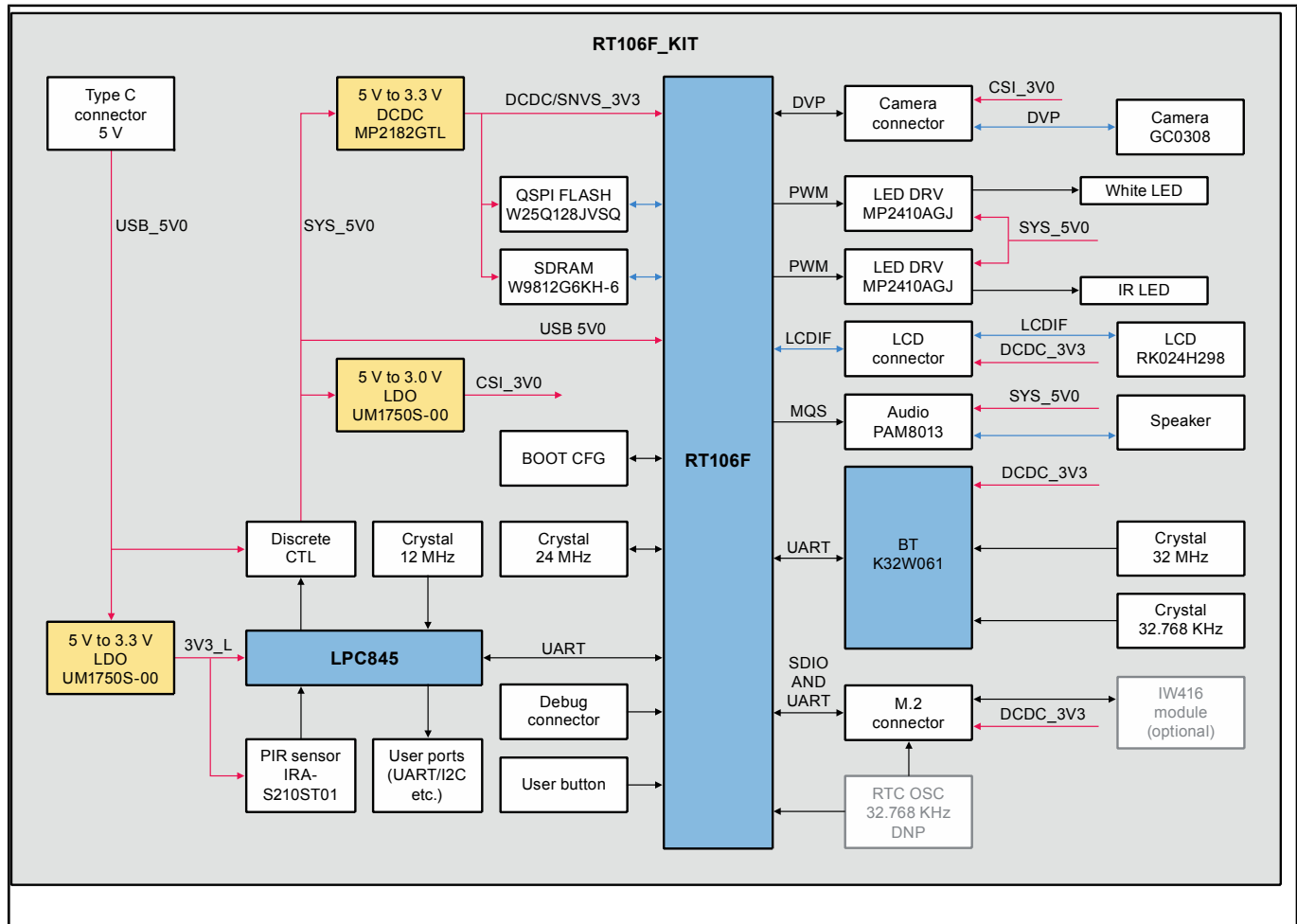

VIZNLC Face Recognition Software Block Diagram

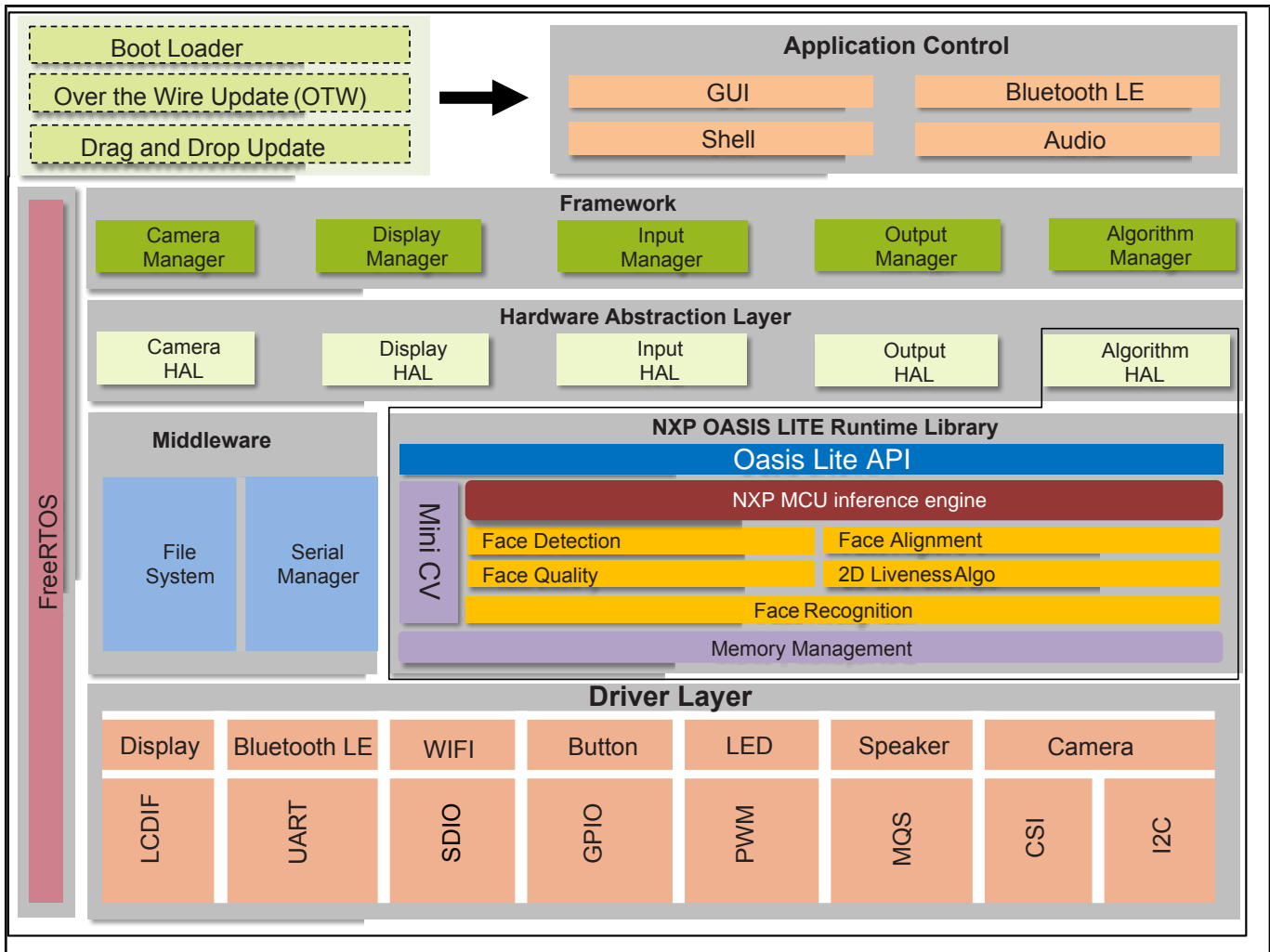

Demo Kit Block Diagram

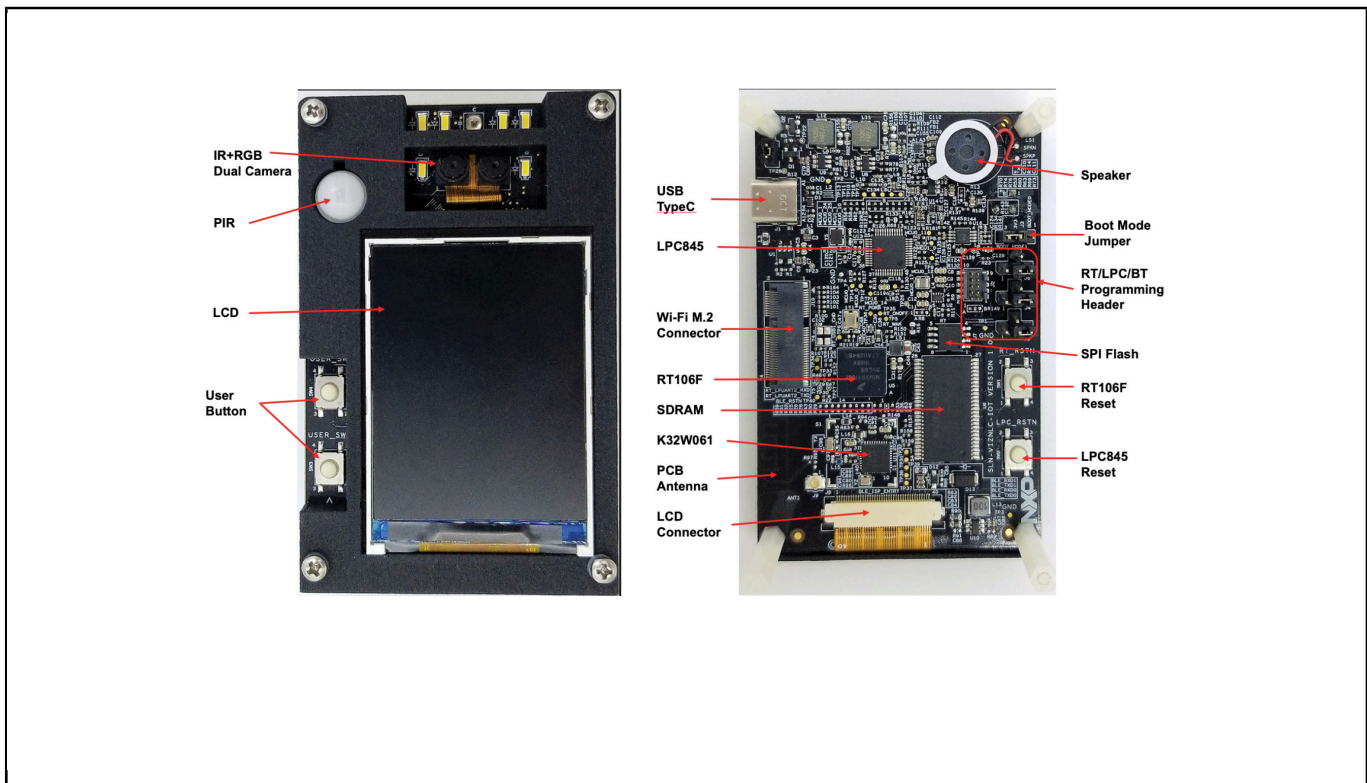

View additional information for [NXP EdgeReady MCU-Based Solution for Face Recognition with Liveness Detection](#).

Note: The information on this document is subject to change without notice.

www.nxp.com

NXP and the NXP logo are trademarks of NXP B.V. All other product or service names are the property of their respective owners. The related technology may be protected by any or all of patents, copyrights, designs and trade secrets. All rights reserved. © 2024 NXP B.V.