



Multiple voltage regulator with switch and ignition buffer

TDA3681

Not Recommended for New Designs

This page contains information on a product that is not recommended for new designs.

Last Updated: Apr 8, 2022

The TDA3681 is a multiple output voltage regulator with a power switch and an ignition buffer. It is intended for use in car radios with or without a microcontroller. The TDA3681 contains the following:

- Four fixed voltage regulators with a foldback current protection (regulators 1, 2, 3 and 4). Regulator 2, which is intended to supply a microcontroller, also operates during load dump and thermal shutdown
- Regulators 3 and 4 have a second supply pin that can be connected to a lower supply voltage (>6.5 V) to reduce the power dissipation
- A power switch with protection, operated by a control input
- Reset and hold outputs that can be used to interface with the microcontroller; the reset signal can be used to call up the microcontroller
- Both supply pins can withstand load dump pulses and negative supply voltages
- Regulator 2, which is in regulation at a backup voltage above 6.5 V
- A provision for the use of a reserve supply capacitor that will hold enough energy for regulator 2 (5 V continuous) to allow a microcontroller to prepare for loss of voltage
- An ignition input Schmitt trigger with push-pull output stage.

Block diagram: TDA3681J, TDA3681JR, TDA3681TH Block Diagram

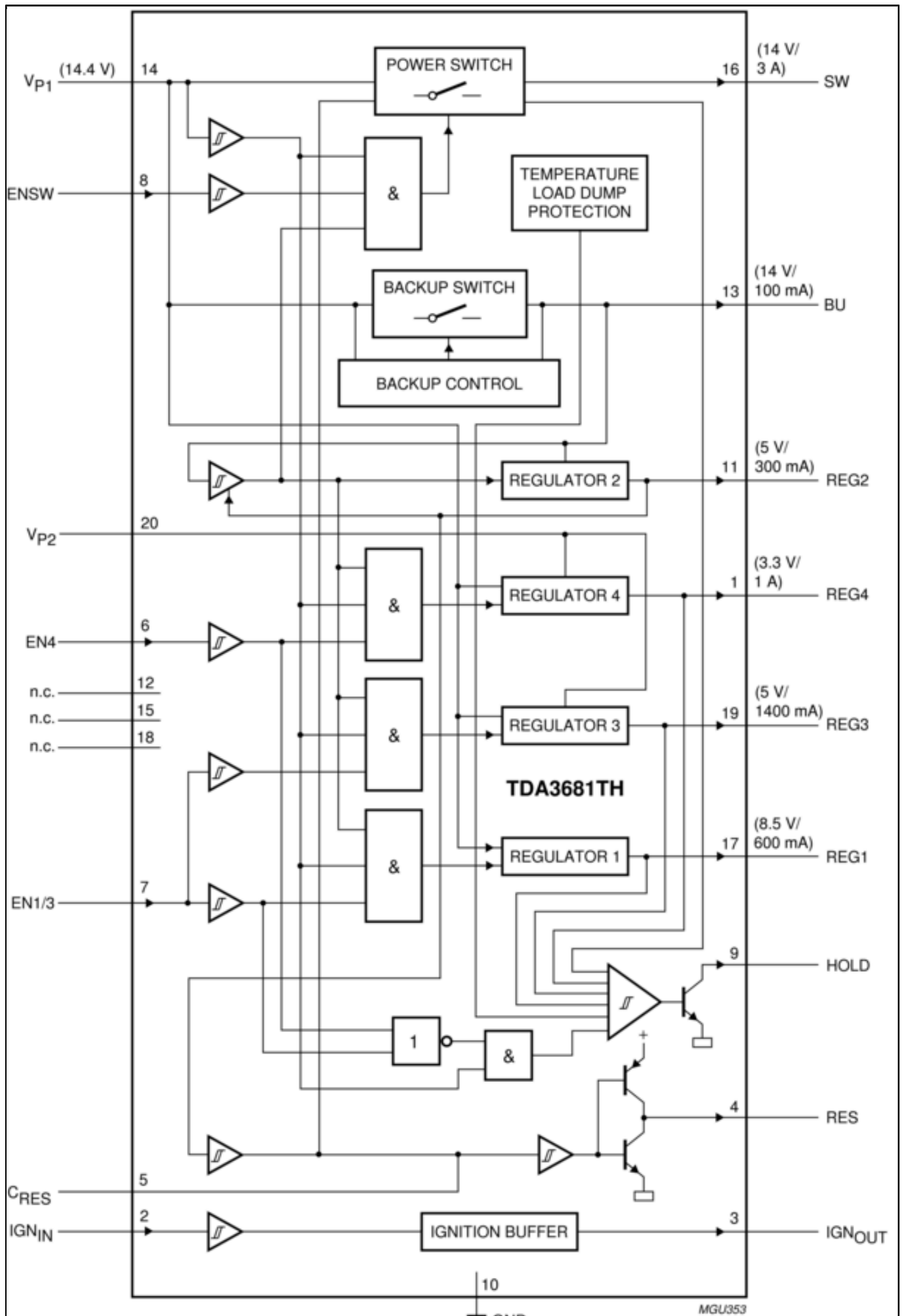

View additional information for [Multiple voltage regulator with switch and ignition buffer](#).

Note: The information on this document is subject to change without notice.

www.nxp.com

NXP and the NXP logo are trademarks of NXP B.V. All other product or service names are the property of their respective owners. The related technology may be protected by any or all of patents, copyrights, designs and trade secrets. All rights reserved. © 2023 NXP B.V.