



# Low-Power Single Card Reader

## TDA8029HL

Last Updated: Apr 8, 2022

The TDA8029 is a complete one chip, low cost, low power, robust smart card reader. Its different power reduction modes and its wide supply voltage range allow its use in portable equipment. Due to specific versatile hardware, a small embedded software program allows the control of many cards available in the market. The control from the host may be done through a standard serial interface.

The TDA8029 may be delivered with standard embedded software. For details on standard embedded software, please refer to “AN10206” for the TDA8029HL/C2.

## Block diagram: TDA8029HL Block Diagram

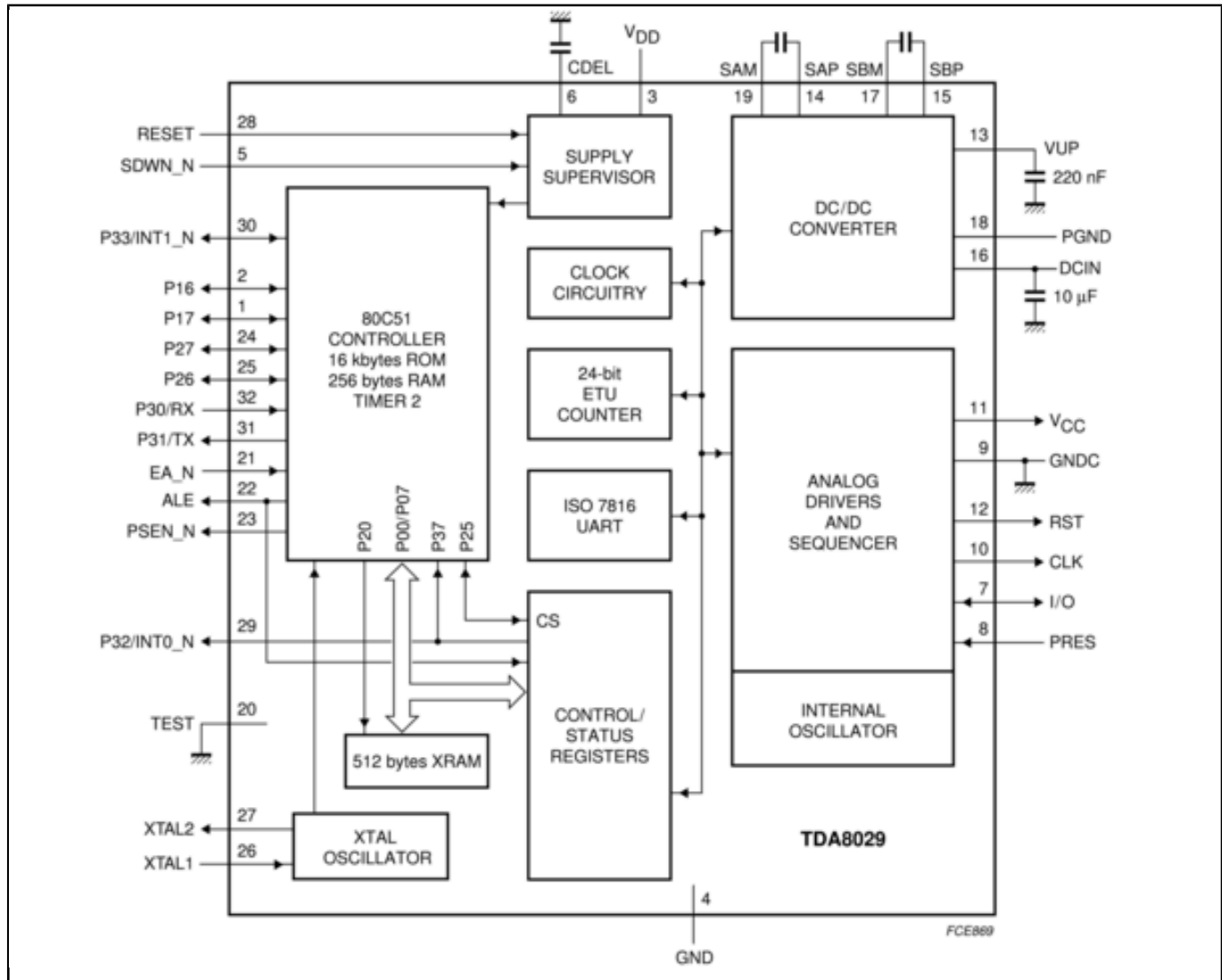

View additional information for [Low-Power Single Card Reader](#).

**Note:** The information on this document is subject to change without notice.

[www.nxp.com](http://www.nxp.com)

NXP and the NXP logo are trademarks of NXP B.V. All other product or service names are the property of their respective owners. The related technology may be protected by any or all of patents, copyrights, designs and trade secrets. All rights reserved. © 2023 NXP B.V.