



LIN Transceiver

TJA1020

Last Updated: Apr 10, 2022

The TJA1020 is the interface between the LIN leader/follower protocol controller and the physical bus in a Local Interconnect Network (LIN). It is primarily intended for in-vehicle sub-networks using baud rates from 2.4 up to 20 Kbaud.

The transmit data stream of the protocol controller at the TXD input is converted by the LIN transceiver into a bus signal with controlled slew rate and wave shaping to minimize EME. The LIN bus output pin is pulled HIGH via an internal termination resistor. For a leader application an external resistor in series with a diode should be connected between pin INH or pin BAT and pin LIN. The receiver detects the data stream at the LIN bus input pin and transfers it via pin RXD to the microcontroller.

In normal transceiver operation the TJA1020 can be switched in the normal slope mode or the low slope mode. In the low slope mode the TJA1020 lengthens the rise and fall slopes of the LIN bus signal, thus further reducing the already very low emission in normal slope mode.

In sleep mode the power consumption of the TJA1020 is very low, whereas in failure modes the power consumption is reduced to a minimum.

Block diagram: TJA1020T Block Diagram

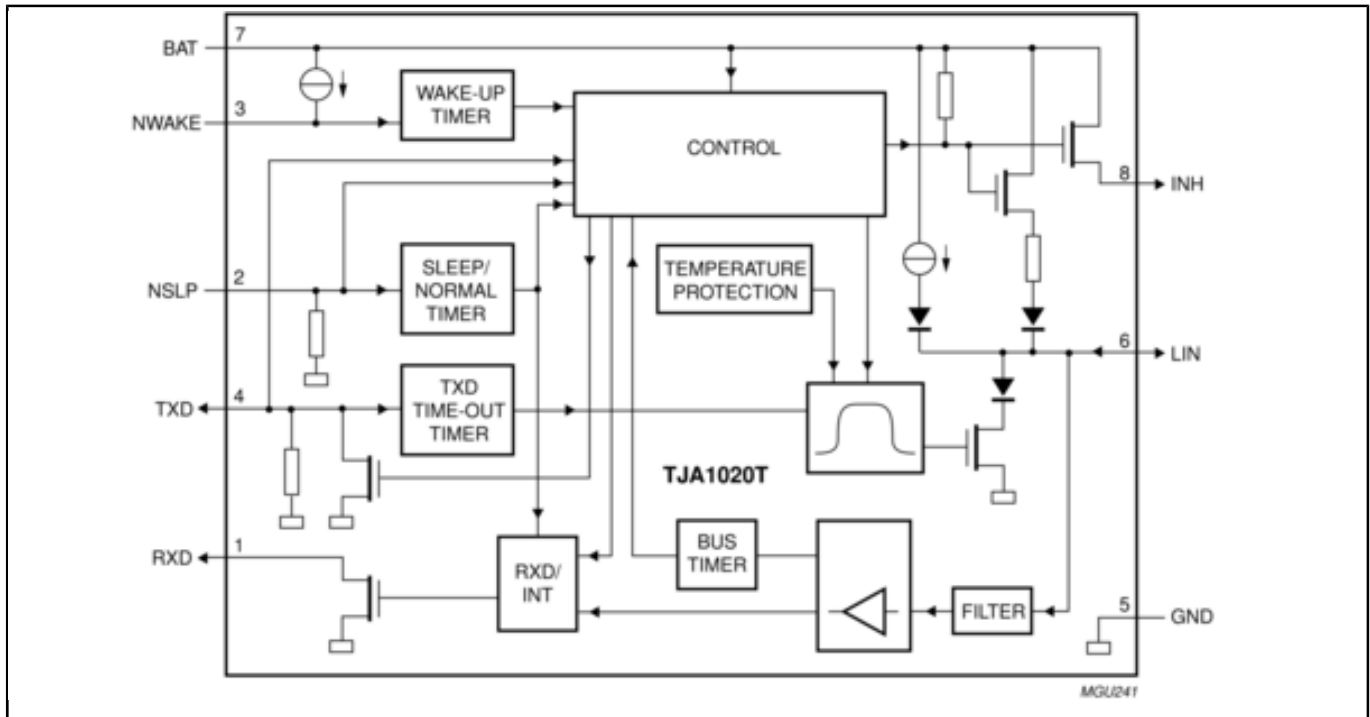

View additional information for [LIN Transceiver](#).

Note: The information on this document is subject to change without notice.

www.nxp.com

NXP and the NXP logo are trademarks of NXP B.V. All other product or service names are the property of their respective owners. The related technology may be protected by any or all of patents, copyrights, designs and trade secrets. All rights reserved. © 2022 NXP B.V.