



Dual High-Speed CAN Transceiver with Standby Mode

TJA1048

Last Updated: Apr 9, 2022

The TJA1048 is a dual high-speed CAN transceiver that provides an interface between a Controller Area Network (CAN) protocol controller and the physical two-wire CAN bus. The transceiver is designed for high-speed CAN applications in the automotive industry, providing the differential transmit and receive capability to (a microcontroller with) a CAN protocol controller.

The TJA1048 belongs to the third generation of high-speed CAN transceivers from NXP Semiconductors, offering significant improvements over first- and second-generation devices such as the TJA1040. It offers improved Electro Magnetic Compatibility (EMC) and ElectroStatic Discharge (ESD) performance, and also features:

- Ideal passive behavior to the CAN bus when the supply voltage is off
- A very low-current Standby mode with bus wake-up capability on both channels
- Can be interfaced directly to microcontrollers with supply voltages from 3 V to 5 V

The TJA1048 implements the CAN physical layer as defined in the current ISO11898 standard (ISO11898-2:2003, ISO11898-5:2007) and the pending updated version of ISO 11898-2:2016. Pending the release of the updated version of ISO11898-2:2016 including CAN FD and SAE J2284-4/5, additional timing parameters defining loop delay symmetry are specified. This implementation enables reliable communication in the CAN FD fast phase at data rates up to 5 Mbit/s.

These features make the TJA1048 an excellent choice for all types of HS-CAN networks containing more than one HS-CAN interface that require a low-power mode with wake-up capability via the CAN bus, especially for Body Control and Gateway units.

TJA1048 Block Diagram Block Diagram

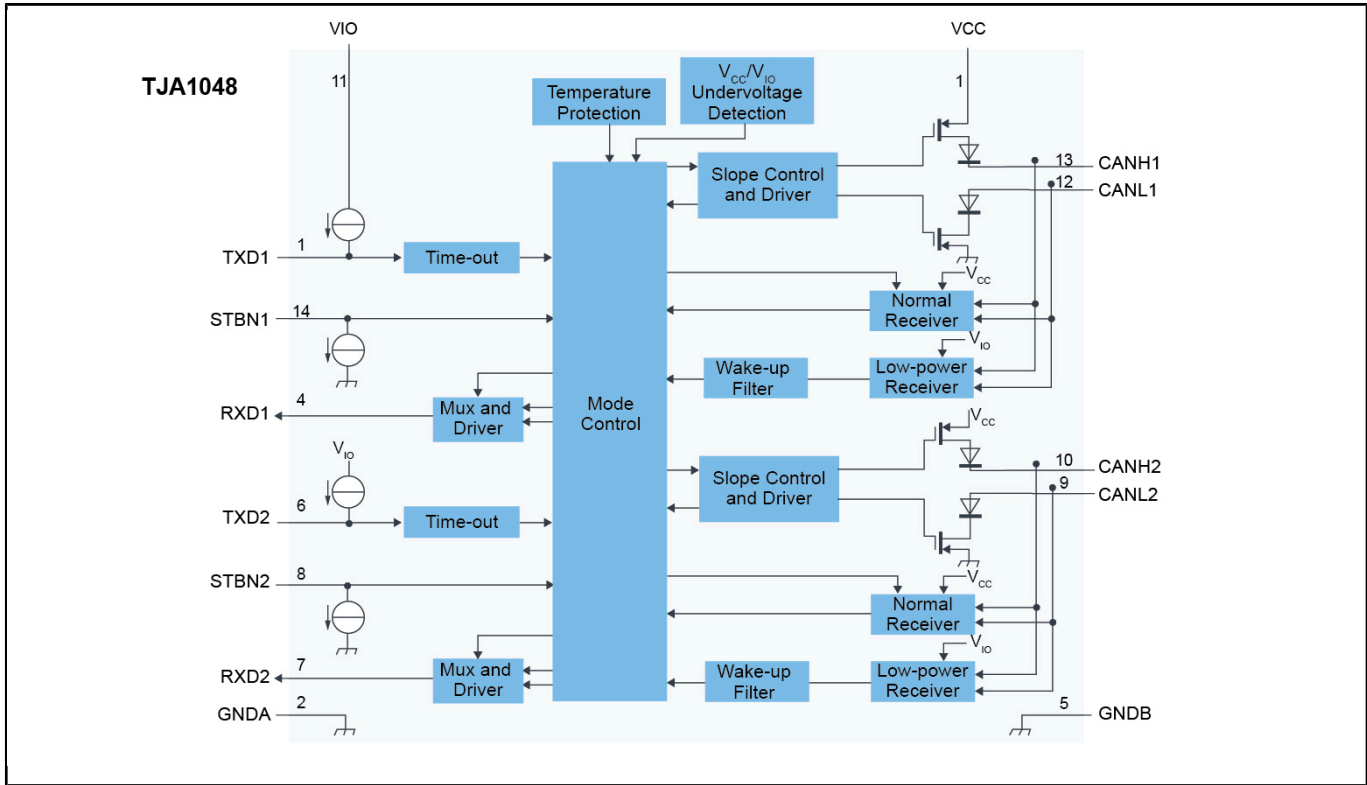

View additional information for [Dual High-Speed CAN Transceiver with Standby Mode](#).

Note: The information on this document is subject to change without notice.

www.nxp.com

NXP and the NXP logo are trademarks of NXP B.V. All other product or service names are the property of their respective owners. The related technology may be protected by any or all of patents, copyrights, designs and trade secrets. All rights reserved. © 2022 NXP B.V.