



High-Speed CAN Transceiver - Mantis Family

TJA1057

Last Updated: Sep 21, 2023

The TJA1057 is part of the Mantis family of high-speed CAN transceivers. It provides an interface between a controller area network (CAN) protocol controller and the physical two-wire CAN bus. The transceiver is designed for high-speed CAN applications in the automotive industry, providing the differential transmit and receive capability to (a microcontroller with) a CAN protocol controller.

The TJA1057 offers a feature set optimized for 12 V automotive applications, with significant improvements over first- and second-generation CAN transceivers from NXP, such as the TJA1050, and excellent electro magnetic compatibility (EMC) performance.

The TJA1057 also displays ideal passive behavior to the CAN bus when the supply voltage is off.

TJA1057 Block Diagram Block Diagram

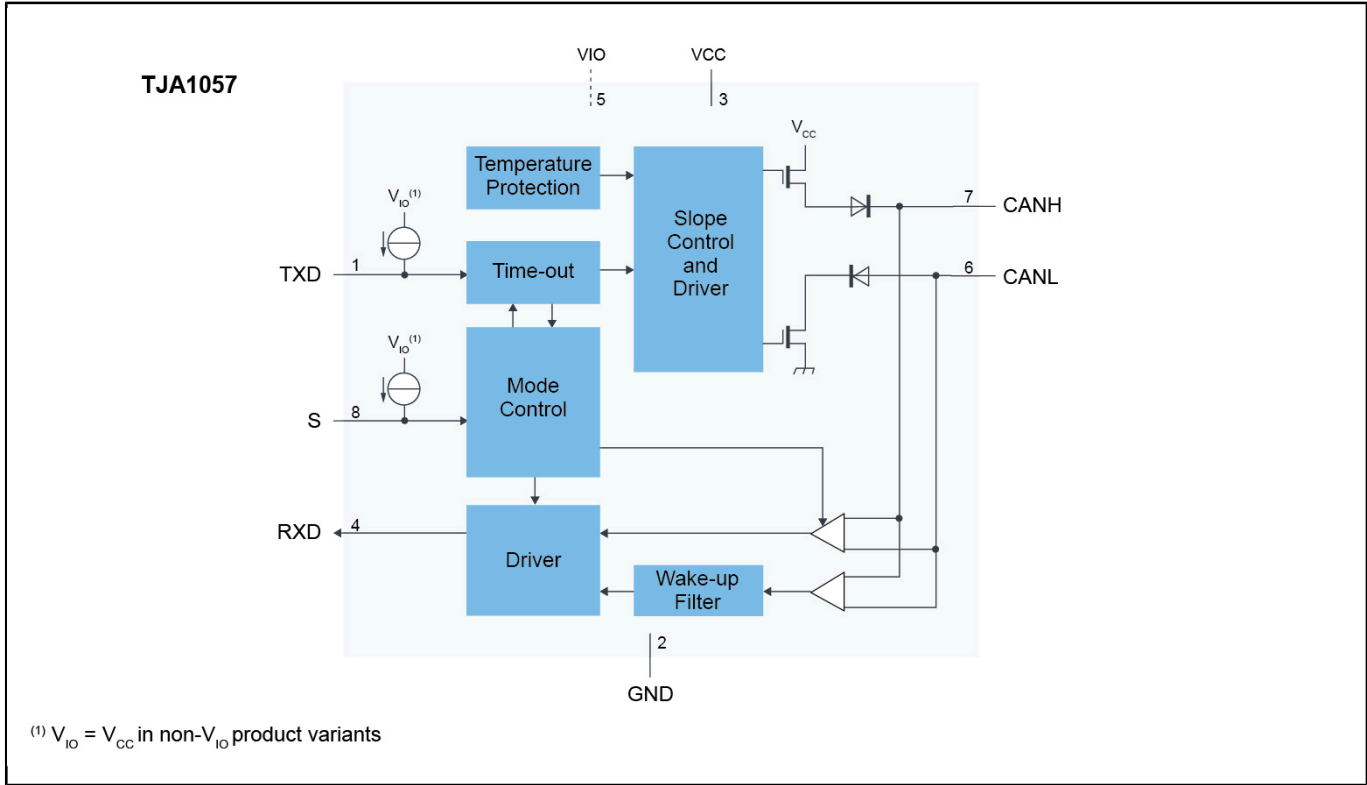

View additional information for [High-Speed CAN Transceiver - Mantis Family](#).

Note: The information on this document is subject to change without notice.

www.nxp.com

NXP and the NXP logo are trademarks of NXP B.V. All other product or service names are the property of their respective owners. The related technology may be protected by any or all of patents, copyrights, designs and trade secrets. All rights reserved. © 2023 NXP B.V.