



i.MX 6Solo Processors – Single-Core, Multimedia, 3D Graphics, Arm[®] Cortex[®]-A9 Core

i.MX6S

Last Updated: Apr 16, 2024

The i.MX 6 series of applications processors combines scalable platforms with broad levels of integration and power-efficient processing capabilities particularly suited to multimedia applications. The i.MX 6Solo processor features:

- Enhanced capabilities of high-tier portable applications by fulfilling MIPS needs of operations systems and games
- Multilevel memory system
- Smart speed technology that enables the designer to deliver a feature-rich product, requiring levels of power far lower than industry expectations
- Dynamic voltage and frequency scaling
- Powerful graphics acceleration
- Interface flexibility
- Integrated power management throughout the device
- Advanced hardware-enabled security

The i.MX 6Solo is supported by companion power management ICs (PMIC) [MMPF0100](#), [MMPF0200](#) and [PF3001](#).

i.MX 6 applications processors are part of NXP's EdgeVerse™ [edge computing](#) platform.

i.MX 6Solo Multimedia Applications Processor Block Diagram Block Diagram

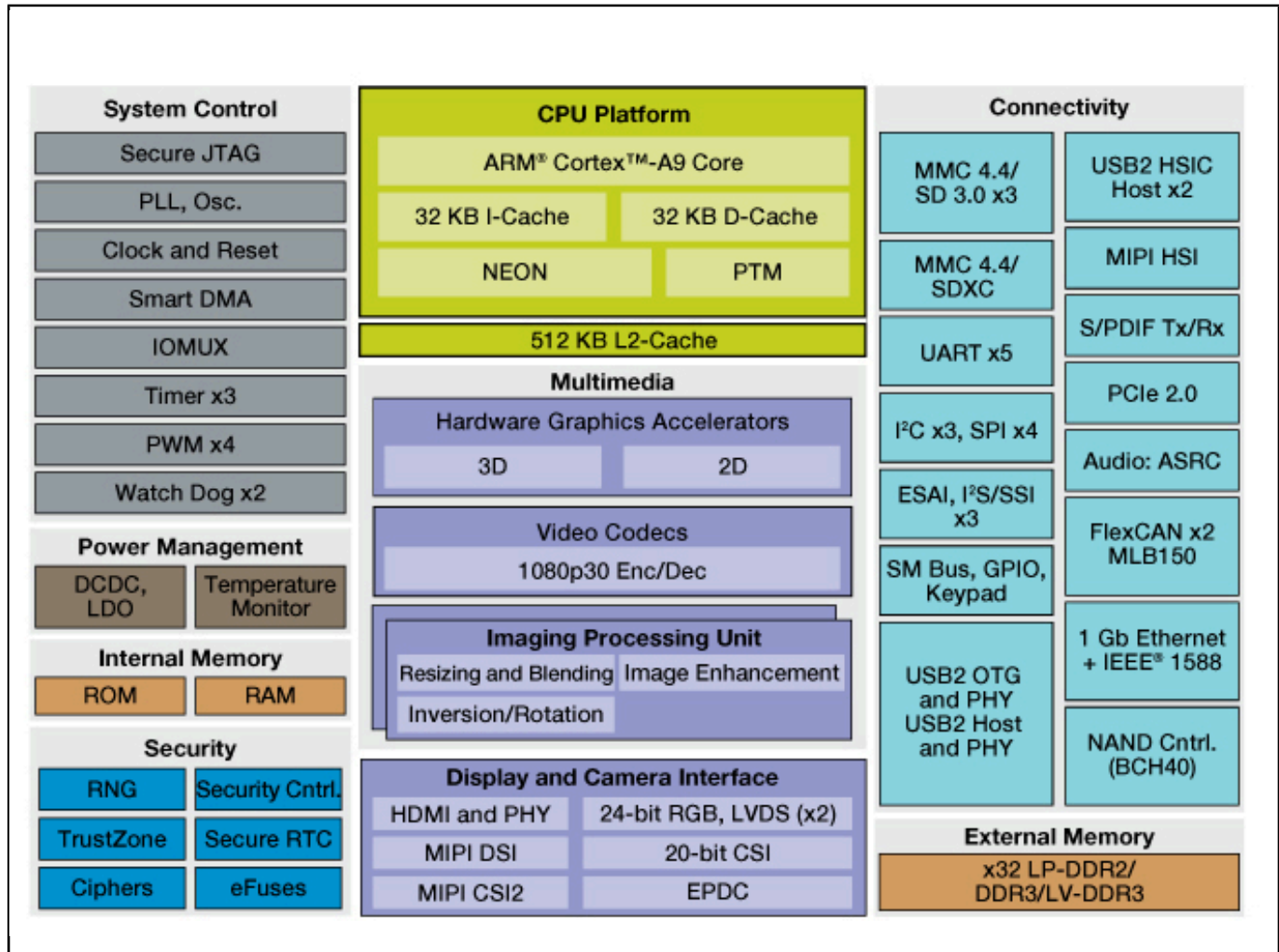

View additional information for [i.MX 6Solo Processors – Single-Core, Multimedia, 3D Graphics, Arm® Cortex®-A9 Core](#).

Note: The information on this document is subject to change without notice.

www.nxp.com

NXP and the NXP logo are trademarks of NXP B.V. All other product or service names are the property of their respective owners. The related technology may be protected by any or all of patents, copyrights, designs and trade secrets. All rights reserved. © 2024 NXP B.V.