



SPI-Programmable H-Bridge Brushed DC Motor Driver

HB2002

Last Updated: Aug 22, 2023

The HB2002 meets shifting demands for motor control applications in automotive and industrial spaces, delivering the efficient and robust performance necessary for tomorrow's safety-critical solutions.

- Safety and Protection: H-Bridge motor driver designed using ISO 26262 processes to support ASIL C and D system qualifications.
- Scalability: SPI-programmable current limits, slew rates, fault reporting, and control schemes enable the same IC to service various applications and motor sizes.
- Thermal Management: Integrated power MOSFETs have temperature-dependent current limit foldback to reduce power and prevent excessive device heating.

HB2002: SPI-Programmable H-Bridge Brushed DC Motor Driver Block Diagram

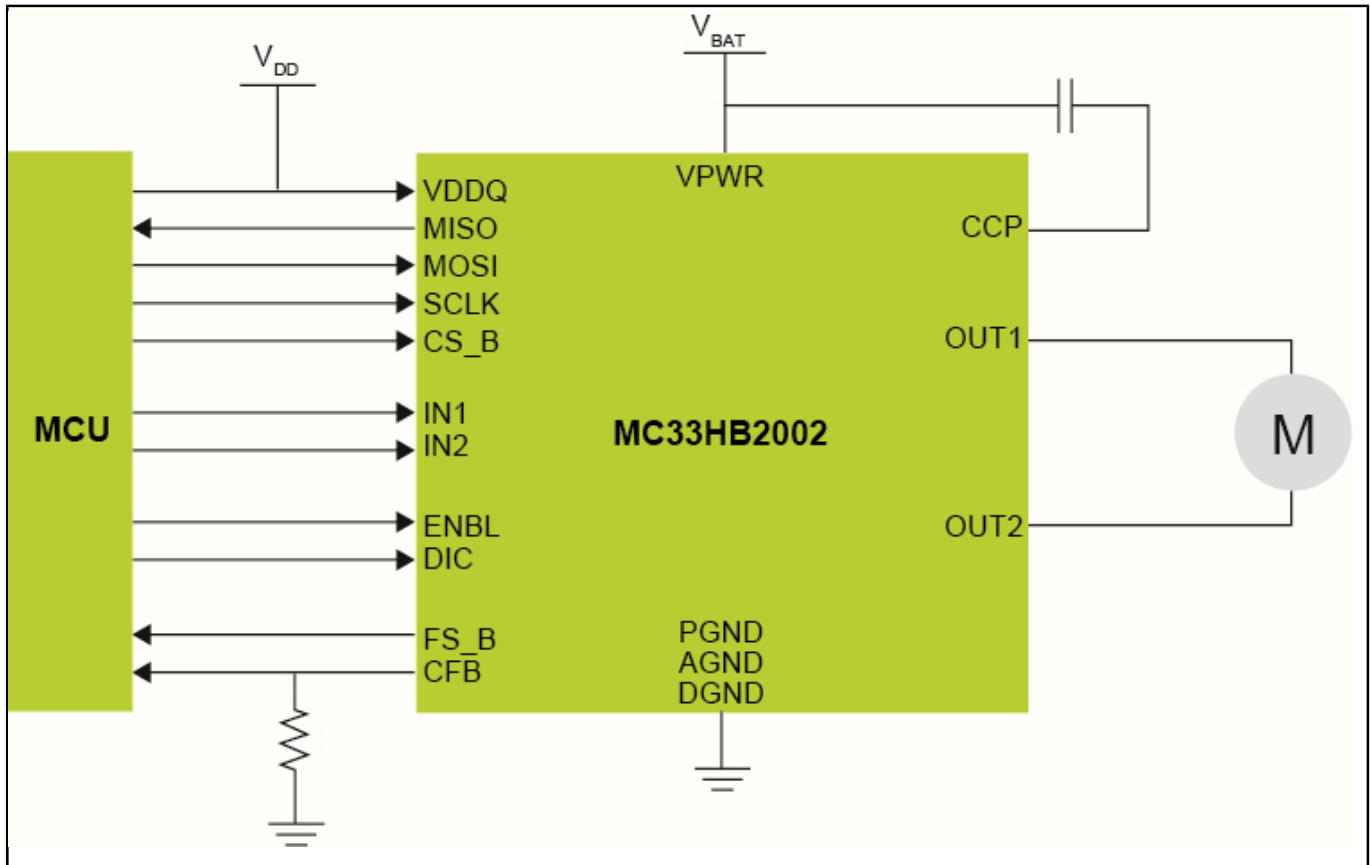

View additional information for [SPI-Programmable H-Bridge Brushed DC Motor Driver](#).

Note: The information on this document is subject to change without notice.

www.nxp.com

NXP and the NXP logo are trademarks of NXP B.V. All other product or service names are the property of their respective owners. The related technology may be protected by any or all of patents, copyrights, designs and trade secrets. All rights reserved. © 2024 NXP B.V.