



MPC5643L 3-phase PMSM Development Kit

MTRCKTDPS5643L

Last Updated: Nov 27, 2023

The MTRCKTDPS5643L motor control development kit is ideal for applications requiring two PMSM motors, like active suspension or electric powertrain. The kit is designed to enable rapid prototyping and evaluation of the motor control application without having to wait for the final hardware design. The kit includes a 32-bit NXP® MPC5643L based controller board and the 3-phase low-voltage power stage board.

An integral part of the automotive motor control development kit is the application software which provides a complete reference implementation of the PMSM motor control application and also takes advantage of the Automotive Math and Motor Control Library Set.

Motor Control Algorithm Concept Block Diagram

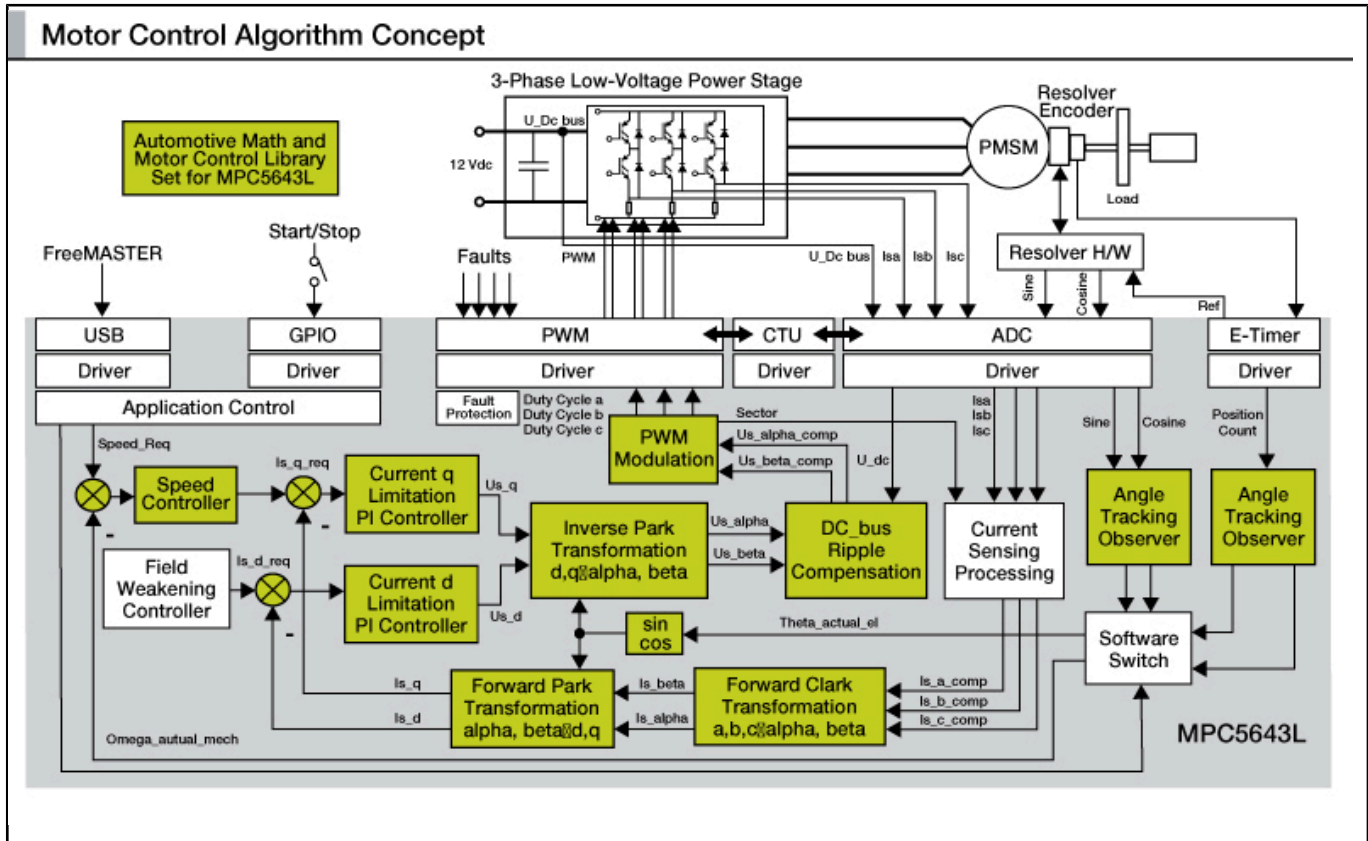

MTRCKTDPS5643L Dual 3-phase PMSM Development Kit with NXP MPC5643L MCU Block Diagram

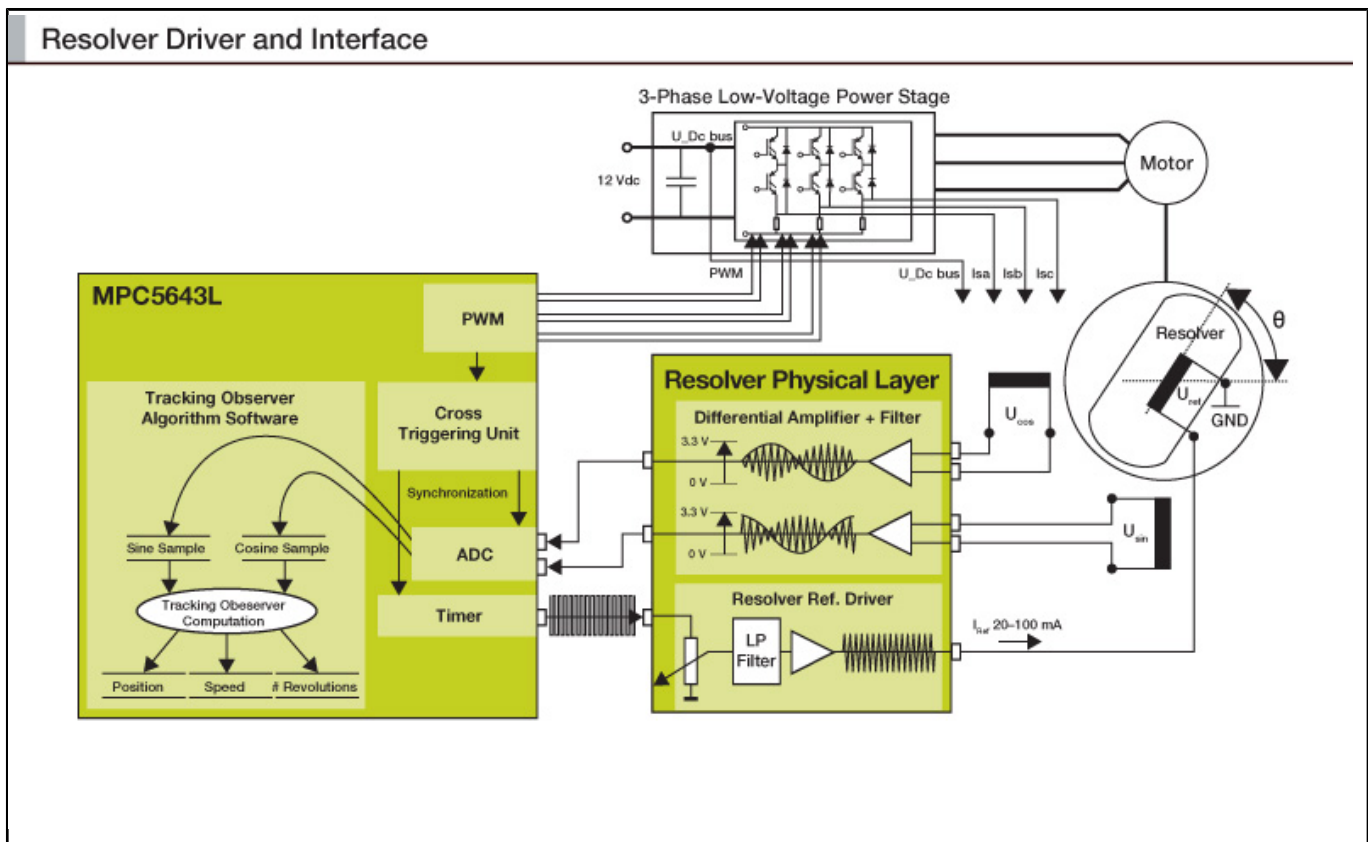

View additional information for [MPC5643L 3-phase PMSM Development Kit](#).

Note: The information on this document is subject to change without notice.

www.nxp.com

NXP and the NXP logo are trademarks of NXP B.V. All other product or service names are the property of their respective owners. The related technology may be protected by any or all of patents, copyrights, designs and trade secrets. All rights reserved. © 2024 NXP B.V.