

NOTE: The theory in this application note is still applicable, but some of the products referenced may be discontinued.

AN1022

Mechanical and Thermal Considerations in Using RF Linear Hybrid Amplifiers

Prepared by: Don Feeney
 Motorola RF Devices

ABSTRACT

Motorola's thin film hybrid amplifiers are medium power (0.2 W to 2.0 W power output) broadband devices (1 to 1000 MHz) that are biased in a class A mode for linear operation. To insure a proper electrical/mechanical interface with adequate RF/thermal characteristics, certain guidelines are presented for the design engineer to obtain maximum electrical performance and the longest operating life.

THERMAL CONSIDERATIONS

A question that often arises from engineers using our hybrid amplifiers is "What is the thermal impedance?" Thermal impedance (expressed as θ_{JC}) is a very real and important parameter for the RF design engineer using discrete solid state devices. However, this term loses its meaning in a multistage hybrid amplifier. Each stage may be biased at different quiescent conditions resulting in different junction temperatures under a given set of environmental conditions. Additionally, hybrid circuit design engineers may speak of θ_{JC} referring to the thermal impedance of a single transistor die mounted on a hybrid circuit using their particular assembly processes. However, this term has no meaning to the customer using their product who can only compute the power consumption of the total amplifier.

To avoid this confusion, Motorola RF Devices simply rates the maximum operating case temperature for their RF linear hybrid amplifiers. These amplifiers are designed so that under the worst case operating conditions, the maximum junction temperature of any of the transistor die will be below 150°C. This junction temperature correlates with our two years of accumulated reliability data which predicts an MTBF in excess of 142 years.

HEATSINK YOUR HYBRID

Like all RF power devices, hybrid amplifiers require heatsinking for proper operation. How much heatsinking is necessary? As much as is required to maintain the case operating temperature at the maximum value under worst case ambient temperature and maximum supply voltage. The presence or absence of the RF signal is insignificant due to the class A bias conditions. Reducing the supply voltage will decrease the power consumption, but it will also decrease the linearity. Attach the hybrid amplifier directly to the chassis, to a module card sidewall, to a small baseplate, or to a mounting bracket that is connected to one of the above. But before you complete your design, verify that the maximum case (flange) temperature for the hybrid amplifier

is within the manufacturer's specified limits under your worst case operating conditions.

One additional note of caution. DO NOT attempt to lap or file the heatsink of the hybrid amplifier. Not only does this void the warranty (considered "mishandling" by the manufacturer), but you can induce substrate cracking during the machining operation. If you need a shorter heatsink, consider the hermetic package option or the low profile package available on some models. Motorola RF linear hybrid amplifiers are shipped with a mounting surface flatness of ± 0.002 ". To improve heatsinking, thermal grease can be used.

PRINTED CIRCUIT BOARD INTERFACE

All Motorola RF linear hybrid amplifiers are internally matched to a nominal characteristic impedance of 50 or 75 ohms, both at the input and the output. This not only reduces the external components normally required to match to these impedances in discrete designs, but it also simplifies the requirements for interfacing printed circuit board connections — for short path lengths, strip line width has little effect on RF performance.

Motorola RF linear hybrid amplifiers feature .020" diameter gold plated pins¹ spaced at .100" centers. Nominal pin length is .460" (.375" for hermetic package).² There is provision for a total of nine pins, but unused pins will be missing (refer to pin configuration diagram for the particular hybrid amplifier). Viewing the hybrid from the top, pin 1 is identified on the left. This is the RF input, usually transformer coupled.³ The two adjacent pins are ground connections. The middle three pins are reserved for power supply connections. Positive polarity units have the power supply pin located in the middle.⁴ Units designed to operate from a negative supply have the power supply connection offset one pin to the left to guard against inadvertent installation in an improper test fixture. The extreme right hand pin is the RF output, and the two adjacent pins are ground connections. All ground connections are internally connected to the flange, except as noted on the functional schematic (refer to particular data sheets).

EXTERNAL COMPONENTS

Although it is not specified as a requirement on the data sheets, it is usually good RF practice to add a low impedance RF bypass capacitor (e.g., 0.1 μ F chip capacitor) located near the power supply pin. Additional decoupling is normally not required. However, some Motorola RF linear hybrids require external chokes and capacitors for proper operation.⁵



Chip capacitors are recommended. A broadband 30 μ H RF choke may be constructed by winding 30 turns of #36AWG magnet wire on a Ferroxcube 891 T050/4C4 core (alternate core is Indiana General P/N CF 12001). With an accompanying order of hybrid amplifiers, this choke may be procured through Motorola.

For Motorola hybrid amplifier model CA2820, the external chokes isolate the transistor from the power supply. Positioning of these chokes will have an effect on the high frequency end of the amplitude response.

TEST FIXTURES

Figures 1 through 10 detail the assembly of standard test fixtures for Motorola's line of RF linear hybrid amplifiers. Much of this mechanical information will prove useful to the engineer who is designing one of these units into his

equipment. The details of the test fixture assembly for the CA2820 presented in Figure 7 apply to most of the standard RF linear hybrid amplifiers (just substitute PC boards, adjust pin spacing, and remove external components as required). Special provisions for adapting this same test fixture for the low profile package, the bent pin option, and the hermetic package option are presented in Figures 8, 9, and 10.

- 1 Pin diameter for hermetic package is .018".
- 2 These pins will mate with sockets manufactured by Amphenol (P/N 502-20071-572) and Barnes (P/N 027-018-02).
- 3 Except for CA2820, which has an internal DC blocking capacitor at the input.
- 4 Except for CA2820 and CA2870. Refer to individual datasheets.
- 5 e.g. CA2820, CA2870

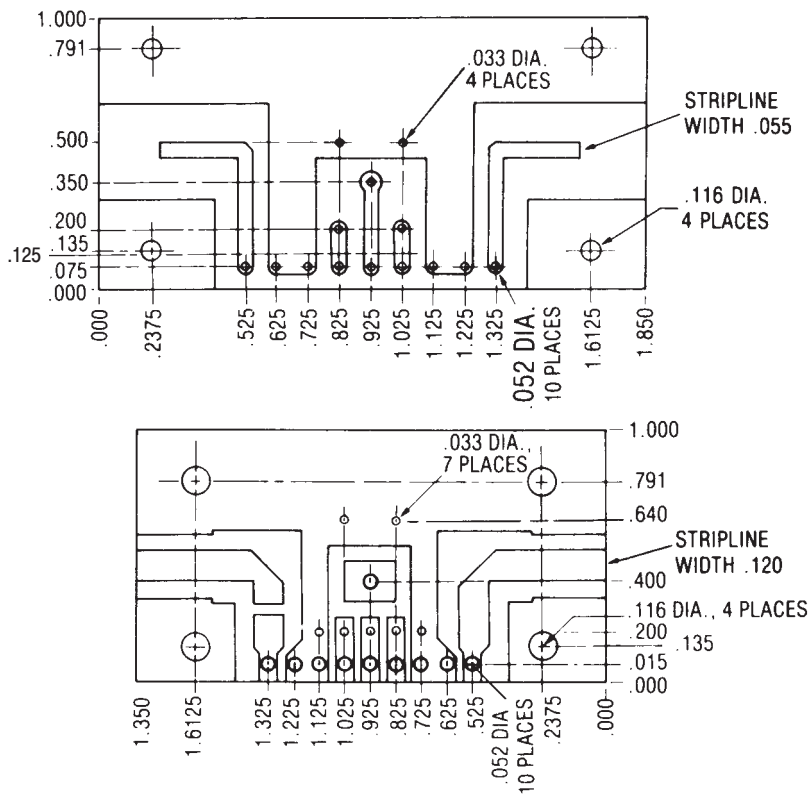

NOTES:

- 1. All dimensions in inches, tolerance $\pm .005$.
- 2. Material is double sided glass epoxy (G10), 1/16" thickness, 1 oz. copper, solder plated.
- 3. TF-06 used for CA2820 only. All other models use TF-03.

Figure 1. PC Board Construction for Hybrid Amplifier Test Fixtures

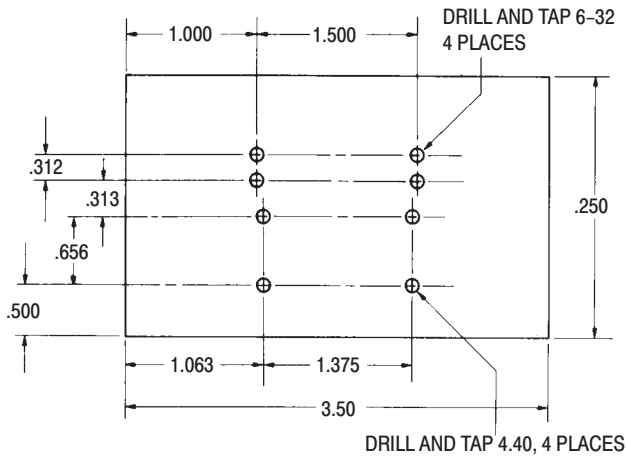

NOTES:

1. All dimensions in inches, tolerance $\pm .005$.
2. Material is 3/8 aluminum.

Figure 2. Heatsink Base Plate Construction for Hybrid Amplifier Test Fixture

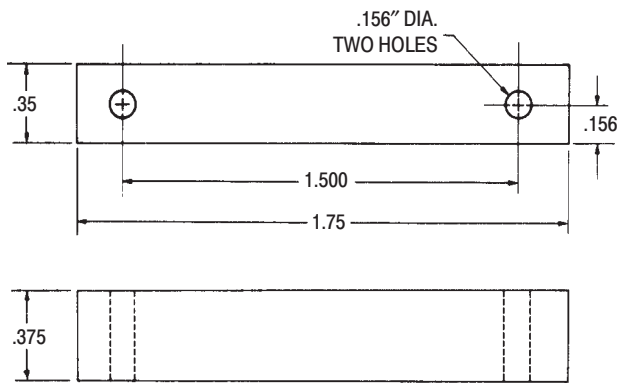

Figure 4. Adapter for Low Profile Package to Standard Hybrid Amplifier Test Fixtures

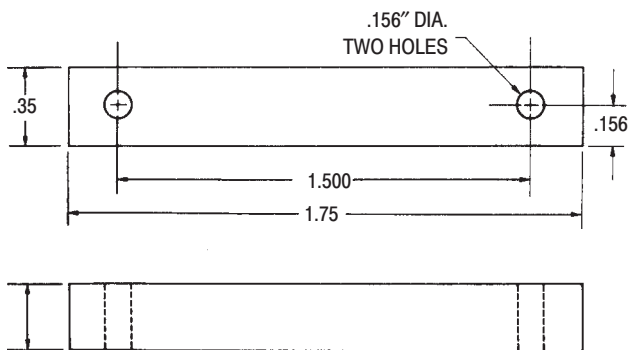
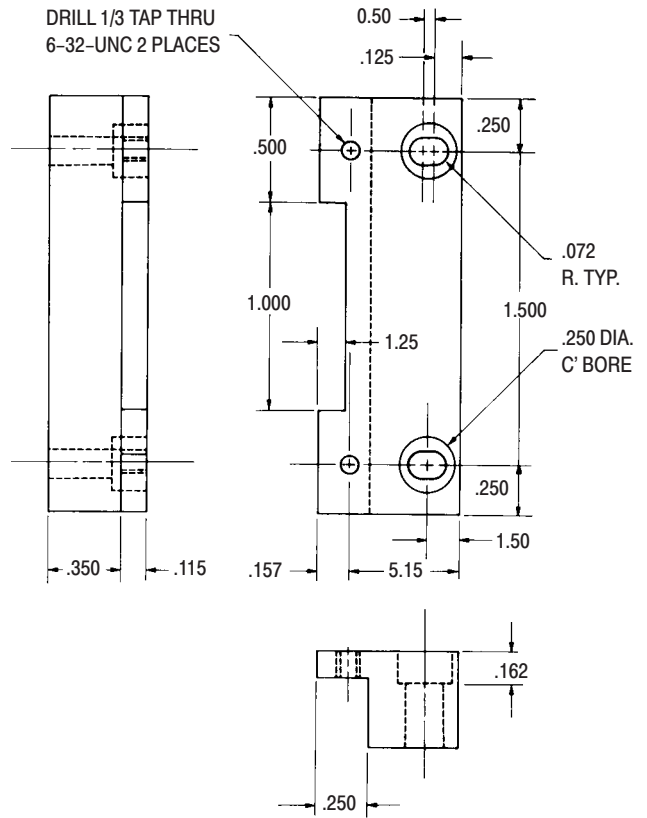

Figure 5. Spacer for Bent Pin Package Option to Standard Hybrid Amplifier Test Fixtures



NOTES:

1. All dimensions in inches, tolerances $\pm .005$.
2. Material is aluminum.

Figure 3. Adapter for Hermetic Package to Standard Hybrid Amplifier Test Fixtures

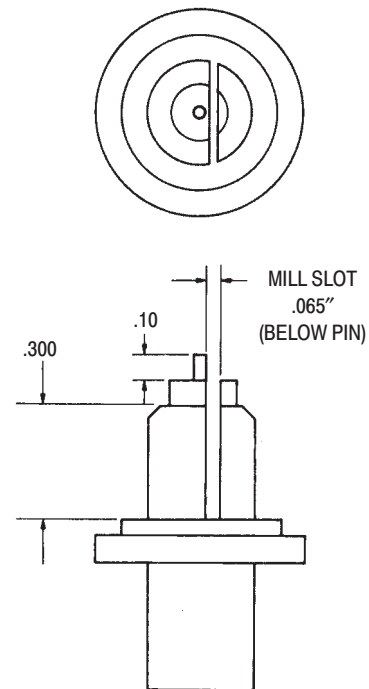

AMPHENOL P/N US-625/U (50Ω)
TROPOMETER P/N UBJ-20 (75Ω)

Figure 6. Modifications to BNC Connector

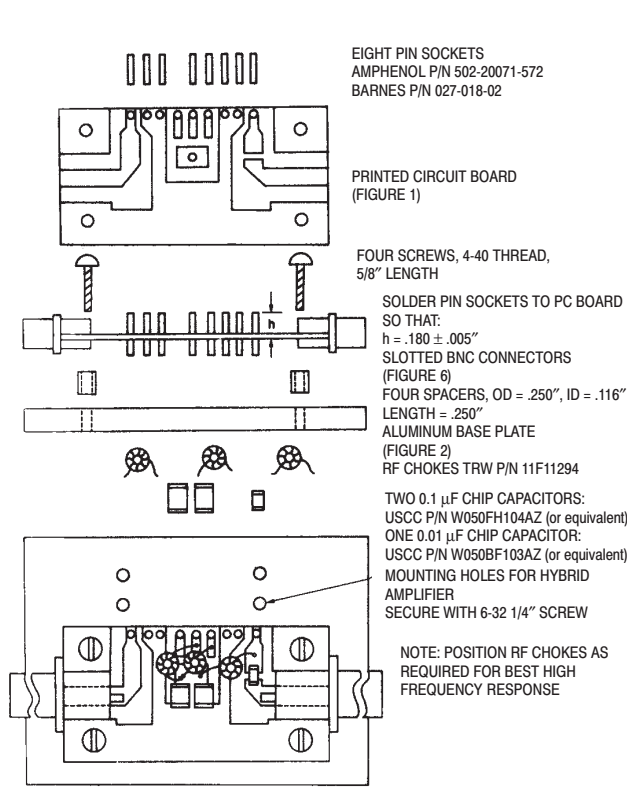

Figure 7. CA2820 Test Fixture Assembly (Case 714F-01)

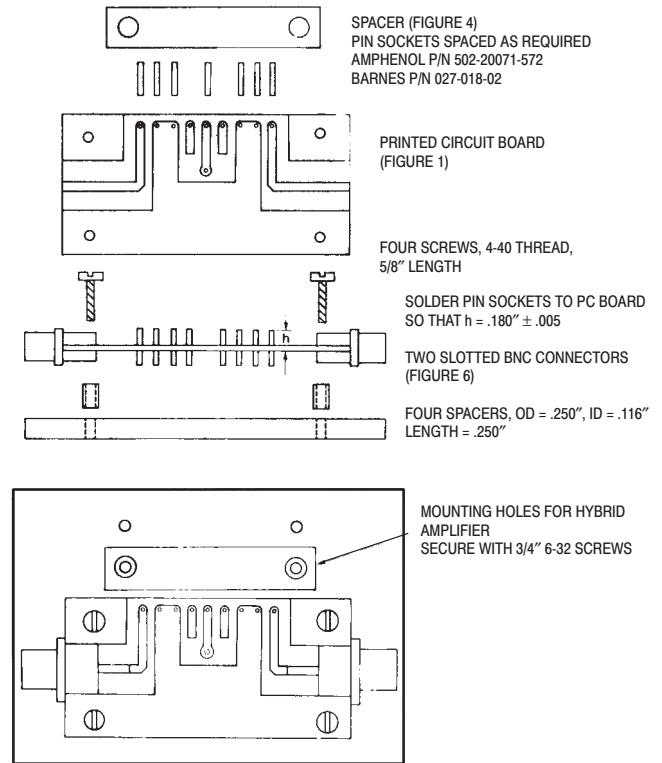

Figure 8. Text Fixture Assembly for Hybrid Amplifiers in Low Profile Package (Case 714G-01)

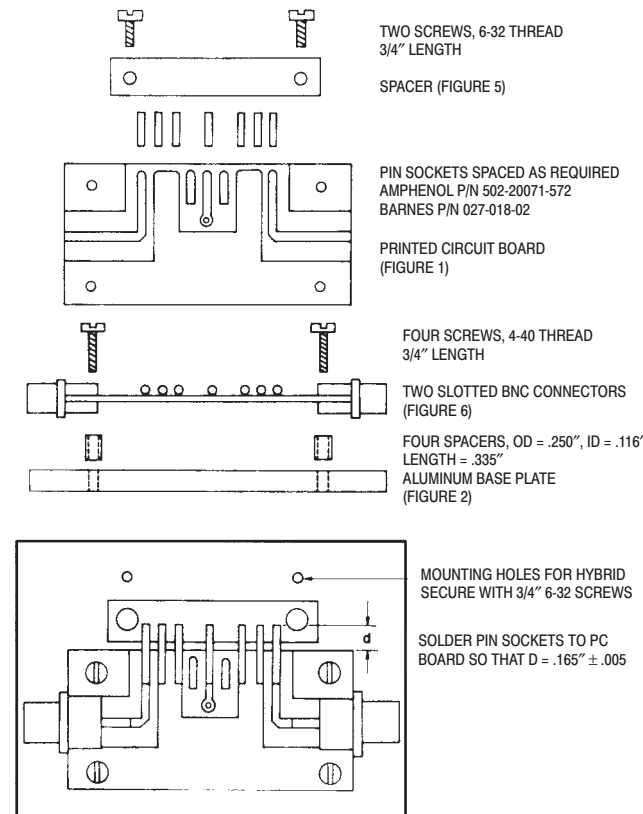

Figure 9. Text Fixture Assembly for Hybrid Amplifiers with Bent Pin Option (Case 714J-01)

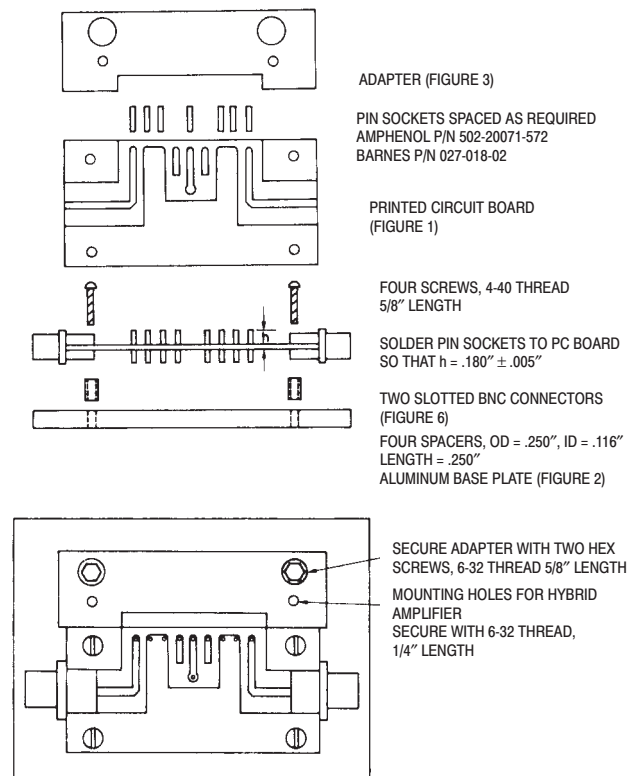



Figure 10. Test Fixture Assembly for Hybrid Amplifiers in Hermetic Package (Case 826-01)





Motorola reserves the right to make changes without further notice to any products herein. Motorola makes no warranty, representation or guarantee regarding the suitability of its products for any particular purpose, nor does Motorola assume any liability arising out of the application or use of any product or circuit, and specifically disclaims any and all liability, including without limitation consequential or incidental damages. "Typical" parameters can and do vary in different applications. All operating parameters, including "Typicals" must be validated for each customer application by customer's technical experts. Motorola does not convey any license under its patent rights nor the rights of others. Motorola products are not designed, intended, or authorized for use as components in systems intended for surgical implant into the body, or other applications intended to support or sustain life, or for any other application in which the failure of the Motorola product could create a situation where personal injury or death may occur. Should Buyer purchase or use Motorola products for any such unintended or unauthorized application, Buyer shall indemnify and hold Motorola and its officers, employees, subsidiaries, affiliates, and distributors harmless against all claims, costs, damages, and expenses, and reasonable attorney fees arising out of, directly or indirectly, any claim of personal injury or death associated with such unintended or unauthorized use, even if such claim alleges that Motorola was negligent regarding the design or manufacture of the part. Motorola and  are registered trademarks of Motorola, Inc. Motorola, Inc. is an Equal Opportunity/Affirmative Action Employer.

Literature Distribution Centers:

USA: Motorola Literature Distribution; P.O. Box 20912; Phoenix, Arizona 85036.

EUROPE: Motorola Ltd.; European Literature Centre; 88 Tanners Drive, Blakelands, Milton Keynes, MK14 5BP, England.

JAPAN: Nippon Motorola Ltd.; 4-32-1, Nishi-Gotanda, Shinagawa-ku, Tokyo 141, Japan.

ASIA PACIFIC: Motorola Semiconductors H.K. Ltd.; Silicon Harbour Center, No. 2 Dai King Street, Tai Po Industrial Estate, Tai Po, N.T., Hong Kong.

MOTOROLA
**For More Information On This Product,
Go to: www.freescale.com**
AN1022/D