

# AN10950

## LPC24XX external memory bus example

Rev. 1.1 — 9 November 2012

Application note

### Document information

Info	Content
<b>Keywords</b>	LPC24XX, EMC, memory, SDRAM, SRAM, flash
<b>Abstract</b>	This application note will detail an example design illustrating how to connect asynchronous and dynamic memory elements to the external memory bus of the LPC24XX. This note also includes a set of suggested design rules which apply to both the schematic capture and layout phases of PCB design.



**Revision history**

Rev	Date	Description
1.1	20121109	<ul style="list-style-type: none"><li>• Updated paragraph 4 in section 2.</li><li>• Added paragraph after table 1.</li></ul>
1	20100706	<ul style="list-style-type: none"><li>• Initial version</li></ul>

**Contact information**

For additional information, please visit: <http://www.nxp.com>

For sales office addresses, please send an email to: [salesaddresses@nxp.com](mailto:salesaddresses@nxp.com)

## 1. Introduction

---

The LPC24XX provides multiple static and dynamic memory chip select outputs to enable designers to work with a large set of memory topologies. Designers must take care to ensure that their PCB satisfies the electrical and timing characteristics of the external memory bus or their embedded systems may not be able to operate reliably at maximum frequency. Consult with the “Dynamic characteristics: Dynamic external memory interface” and “Dynamic characteristics: Static external memory interface” sections of the LPC24XX Data Sheet for a detailed list of specifications.

The ability of a memory bus with multiple devices to operate properly is dependent on several factors: the electrical characteristics of the memory devices, the operating frequency of memory transactions, the length of the traces between the LPC24XX and memory device, as well as the voltage levels being used.

## 2. Suggestions for achieving peak performance

---

Several factors can affect the performance of an embedded system using the LPC24XX. Signal integrity of the external memory bus is important in order to achieve robust operation at 72 MHz. Operating performance can also be negatively impacted by the choice of memory topologies in a design.

One may need to evaluate whether a single or dual memory device design is preferred. In order to reduce the size of a PCB, a designer may choose to use a single 16-bit memory device in their system. This would meet the loading requirements on the external memory bus and may operate reliably at 72 MHz, but because the data bus is constricted performance will be degraded.

In order to improve the performance, one might simply add an additional 16-bit memory. Without proper consideration to signal integrity, however, this additional 16-bit device may result in a marginal design. If care is not taken to properly fan out the memory bus to all memory elements, the bus may become improperly loaded. This can be mitigated by using buffer circuitry in the case of static memories, but the additional parts can increase board costs. In the case of dynamic memories this can be overcome by using a lower clock frequency, at the price of reducing performance.

As seen in [Table 1](#), if a design used an AM29LV64 flash memory and a combination of two 16-bit HYB39S128 SDRAM, the I/O pins would have a loading of 18.0 pF (without taking parasitic capacitances of the PCB into account). Many designs are not this simplistic, however, and if the design required the use of an additional SRAM (or a peripheral device using an SRAM interface) the loading on the data bus could increase.

The recommended topology consists of a single 32-bit wide SDRAM memory device. This way the bus loading is not excessive, nor are additional data transfers required to achieve maximum throughput.

Always remember to properly configure the EMC in software to match the memory topology for a given design. Each channel's EMCDynamicConfig register should be configured as per Table 87 of the LPC24XX User Manual to ensure proper functionality. Also note that the EMC of the LPC24XX supports a maximum of 256 MB per memory range.

**Table 1. Loading characteristics**  
 Maximum loading by various memory ICs<sup>[1]</sup>

Part	Clock pin	Data width	Native input, 32 bit wide input	Input/output
HYB39S128	3.5 pF	16 bits	3.8 pF , 7.6 pF	6.0 pF
MT48LC4M32B2	4.0 pF	32 bits	4.0 pF , 4.0 pF	6.5 pF
M29EW	n/a	16 bits	7.0 pF , 14.0 pF	5.0 pF
AM29LV64	n/a	16 bits	7.5 pF , 15.0 pF	12.0 pF
CY62256VN	n/a	8 bits	6.0 pF , 24.0 pF	8.0 pF

[1] The values specified in the table are taken from memory IC's datasheets.

The total capacitive loading on the external memory controller pins can affect the timing for all devices on the memory bus, including the LPC24XX's. User should carefully read the data sheets for all devices on the memory bus, including the LPC24XX's electrical and timing specifications to make sure their applications have enough margin to meet the timing specifications. Please be aware that the LPC24XX's external memory controller timing specifications in the datasheet are based on a balanced loading of 30 pF on each external controller memory pin.

### 3. Suggested design rules

The following rules act as a collection of guidelines, which if properly followed will reduce the risk of a design failing. However, in some instances it is not possible to meet all of these requirements; if proper signal integrity analysis of the design is conducted, depending on the results of simulation it may be possible to build a robust design which does not utilize every one of these recommendations.

#### 3.1 General rules

Because Dynamic memories rely heavily on their clocks, it is important to minimize latency and jitter on the clock output signals in relation to the rest of the external memory bus. A six layer PCB with power planes is recommended for high performance designs. Ensure that both the LPC24XX and all memory elements are properly decoupled from their power supplies with low-ESR capacitors (MLCC or Tantalum). Consult all chosen memory device documentation for recommended decoupling capacitors arrangements. If analysis cannot be done, a general recommendation of at least a single 4.7 uF bulk capacitor per device in combination with a 100 nF per supply pin should work reliably in most cases.

When using a mixture of dynamic and static memories (as shown in the following example) it is recommended that all signals being used in the static memory bus are buffered prior to arriving at memory devices. Any signals which arrive at a connector or are taken off board should also be buffered. It is recommended that the entire bus, including all control and address signals (rather than simply the data lines) be buffered to ensure all signals arrive downstream with minimal jitter or skew.

Dynamic memories typically are not buffered due to their synchronous nature. Ensure that the selected memory devices do not exceed the electrical characteristics of the CLKOUT signals. In order to reduce reflections on the dynamic memory bus, it is recommended that the data bus on the LPC24XX and on all dynamic memory devices is properly terminated.

### 3.2 Schematic

When using multiple banks of dynamic memory, evenly distribute CLKOUT[1:0] amongst the memory banks, rather than disproportionately loading any individual clock. Be sure that the connectivity of BA[1:0] on memory devices is connected to their multi-function pins A[14:13] on the LPC24XX (even when using lower density memories with fewer address lines).

### 3.3 Placement

Memory elements should be placed as close as possible to the LPC24XX. If interconnecting of the memory bus cannot be accomplished without the use of vias, care should be taken to ensure that no unnecessary vias are added to the traces. While it is not a strict requirement, stripline transmission lines are preferred.

### 3.4 Routing

Non-buffered interconnecting traces should be as short as possible, and are not recommended to exceed 50 mm. When a bus is branched, ensure that all stub connection lengths are within  $\pm 5.0$  mm of each other. Orthogonal connections should jog using 45° tapers or smooth curves, rather than 90° corners. See [Fig 9](#) for the recommended physical placement of devices.

## 4. Example: Embedded uCLinux (no-MMU support)

A common use for the LPC24XX involves the device running an embedded distribution of the Linux operating system without MMU support, such as uCLinux. Typically these designs will use a non-volatile memory (such as parallel NOR flash) to store the root file system and a compressed kernel image, which is copied by the boot loader into a high speed memory (such as an SDRAM) for execution. This application note will cover the design and analysis of a simple embedded system using an LPC24XX with NOR flash and SDRAM while insuring that it will operate at maximum frequency.

The non-volatile memory is usually accessed only during system startup by the boot loader and during field updates. Because of this limited use a designer will typically accept the tradeoff between the performance penalty incurred by the use of a 16-bit wide device and reduced cost due to decreased part count.

## 5. Design details

The design in this application note is as follows: A single 32-bit wide SDRAM will be connected to the external memory controller without the use of external buffering circuitry. It is critical that the memory be connected with traces which do not add excessive capacitance to the bus. A thorough design analysis should always be conducted to ensure that the electrical specifications of the LPC24XX are met.

The LPC24XX will boot from a single 16-bit wide NOR FLASH memory with buffered data, address and control signals. This example design is meant primarily to illustrate how to buffer the asynchronous bus of the LPC24XX, and it is assumed that a real end user design may require additional asynchronous memory devices in addition to the NOR FLASH. Notice that the memory structure of the MT48LC4M32B2 is compatible with the "32 bit external bus high-performance address mapping" of the EMC as seen in Table 87 in the LPC24XX User Manual. Also note that the MT48LC4M32B2 can only operate at frequencies above 50 MHz with CAS latencies of 2 or 3.

When using LPC2420/60/70 parts care must be taken to ensure boot memory is connected to the proper chip select lines and that the BOOT[1:0] pins properly reflect the bus width of the attached memory when they are sampled at startup. Section 8.6 “LPC2420/60/70 boot control” of the LPC24XX User Manual details the startup behavior and requirements.

## 6. Example IC bill of materials

**Table 2. Bill of materials**

Designator	Manufacturer	Part Number	Description
U1	NXP	LPC2478FBD208	ARM7 32-bit microcontroller
U2	Micron	MT48LC4M32B2	SDRAM 128 Mbit
U3,U4,U5	NXP	74ABT162245A	16-bit bus transceiver
U6	Spansion	AM29LV641DH101REI	4M x 16 flash memory
C1-C12,C14-C17,C19-C22,C24-C27,C29-C32	Murata	GRM155R61A104KA01D	0.100 uF 25V X7R 0603
C13,C18,C23,C28	Kemet	C0603C475K8PACTU	4.7 uF 10V X5R 0603
R11-R12	Unspecified	Generic 0 Ohm	Debug jumper
R5,R7,R13-R16	Unspecified	Generic 500-1500 Ohm	Pull up/down
R1-4,R6,R8-R10	CTS	742C163220JPTR	20.0 Ohm array

## 7. Schematics

Please be aware that the following schematics are lacking many application specific connections, such as input power conversion, USB connectivity, additional LPC24XX peripherals, etc. While care has been taken to demonstrate a full performance example using the external memory bus, the included schematics alone are not sufficient for PCB fabrication.

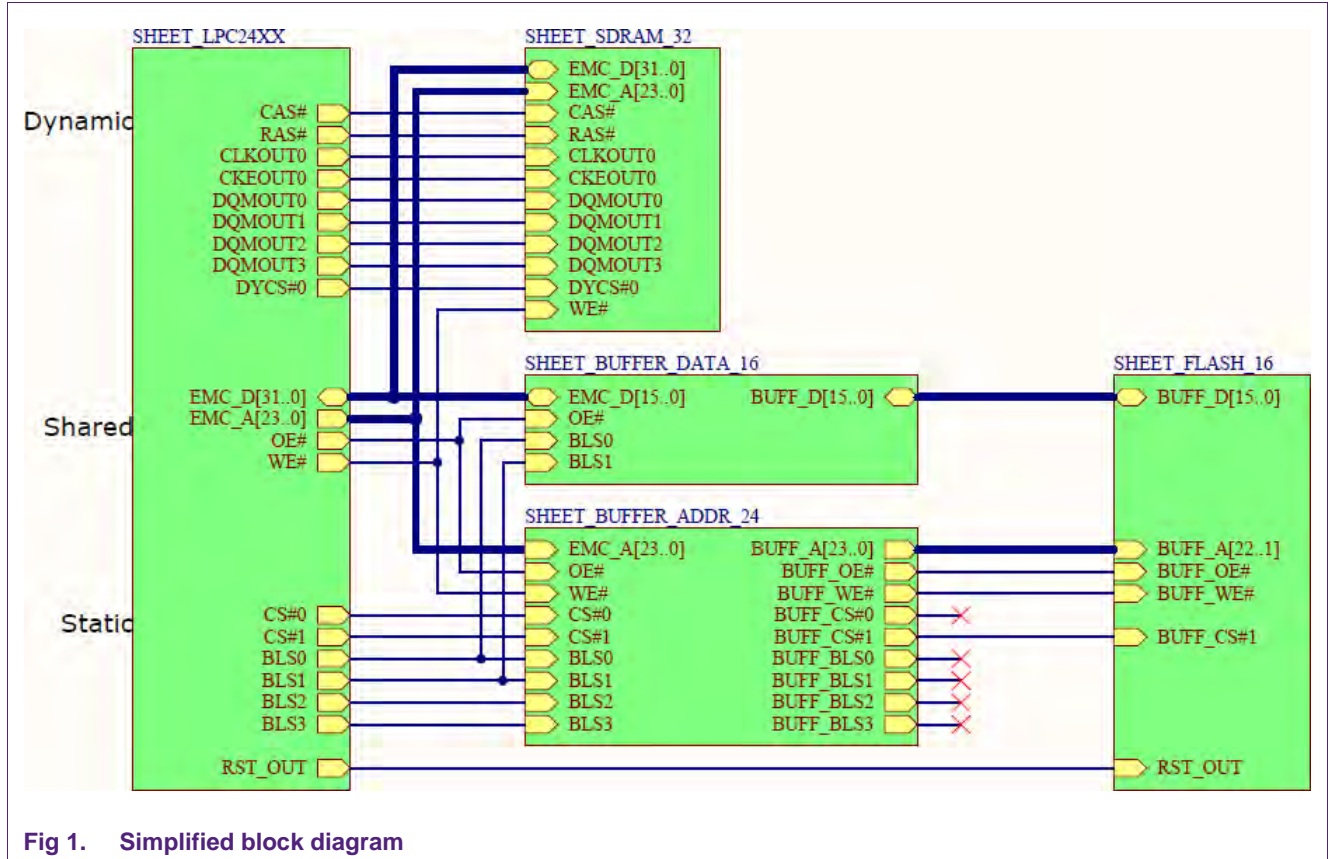
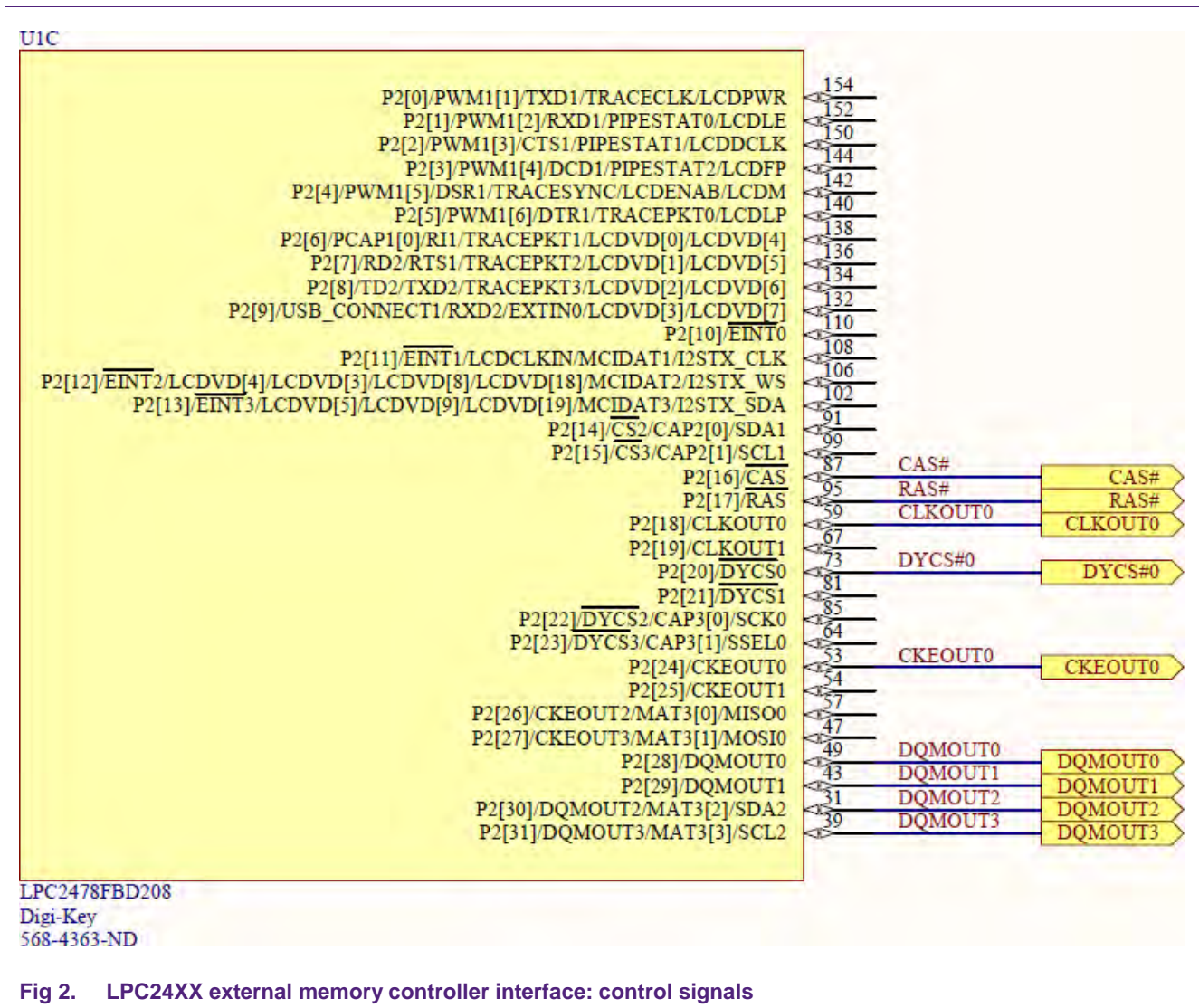
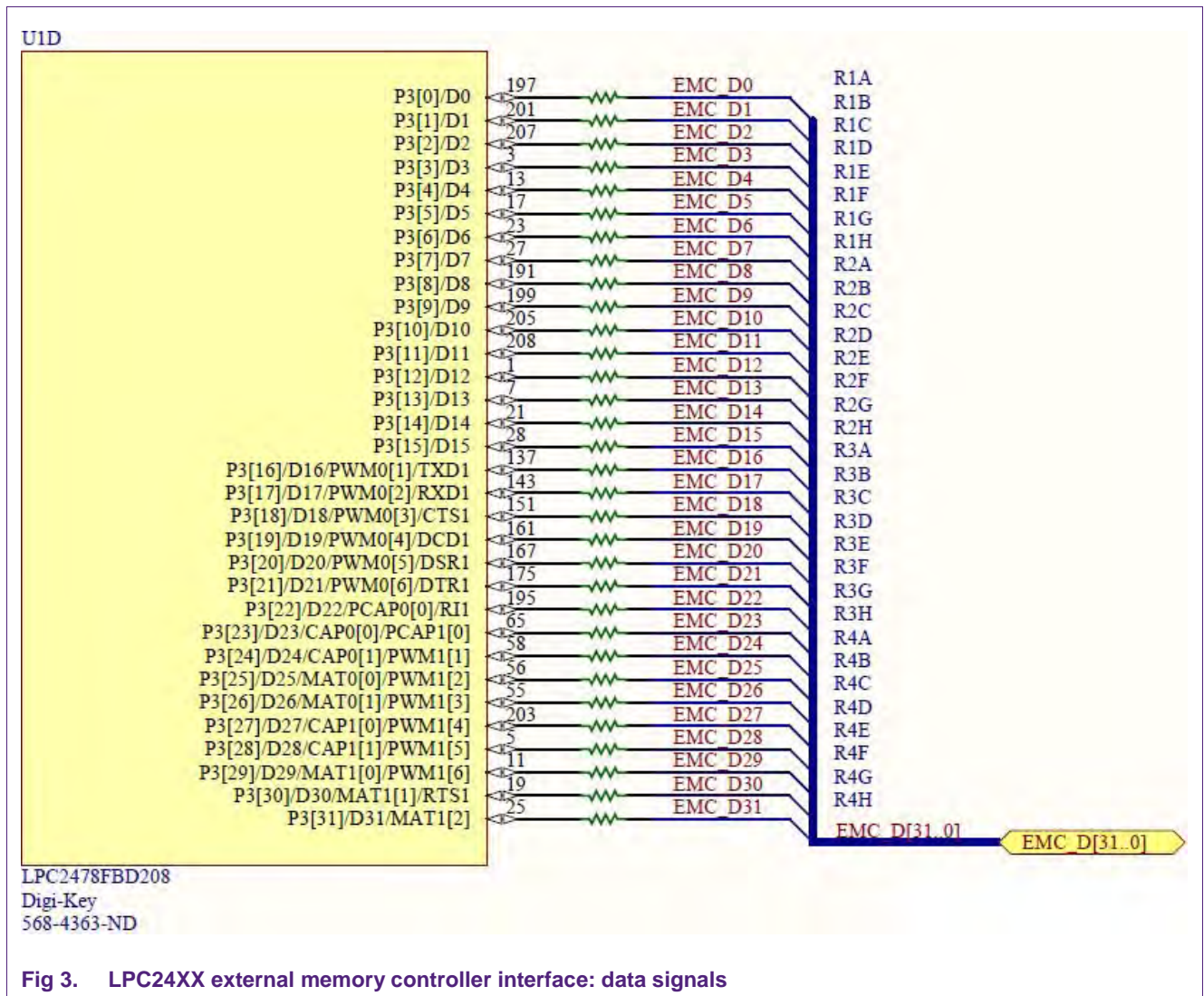

Fig 1. Simplified block diagram









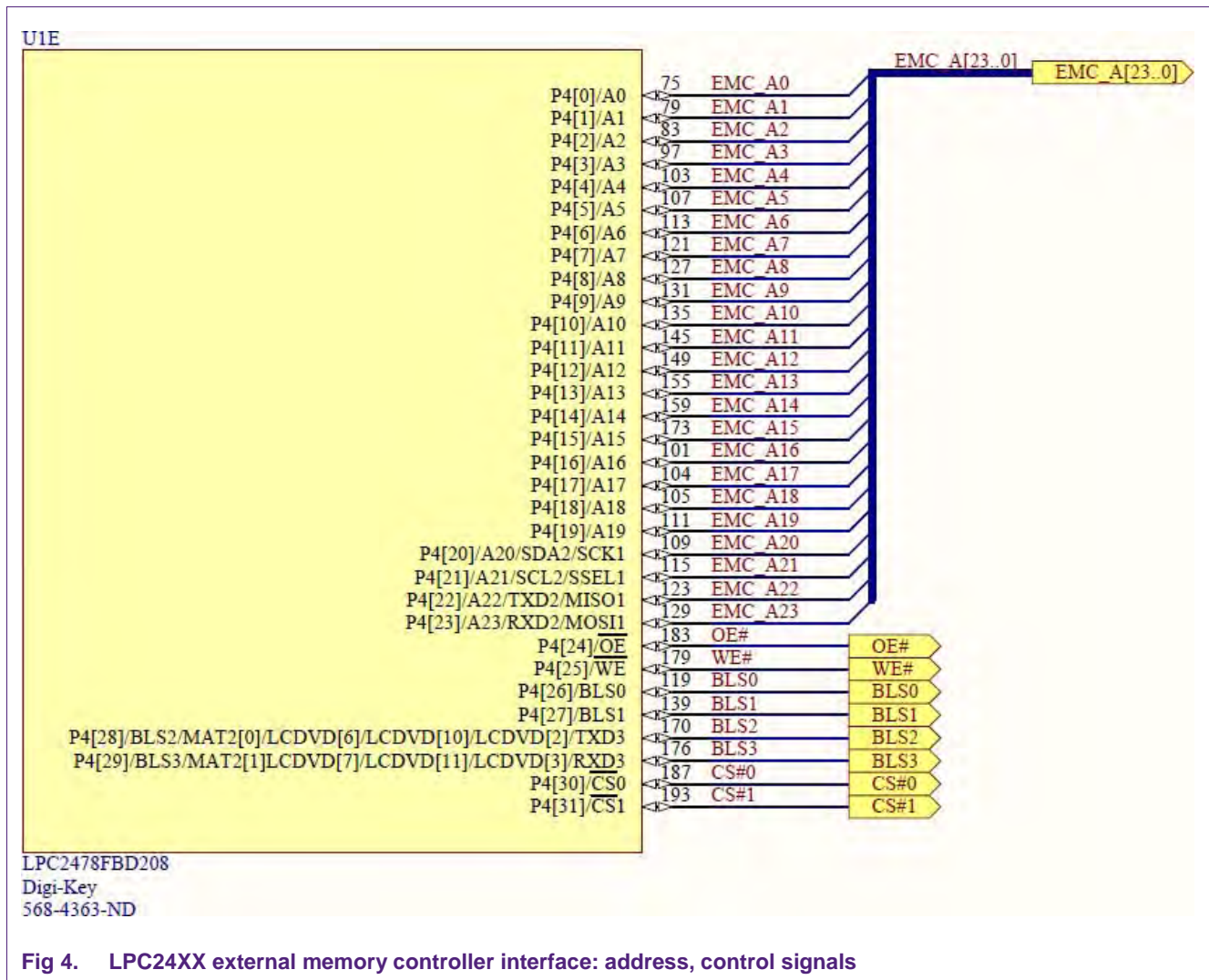

Fig 4. LPC24XX external memory controller interface: address, control signals

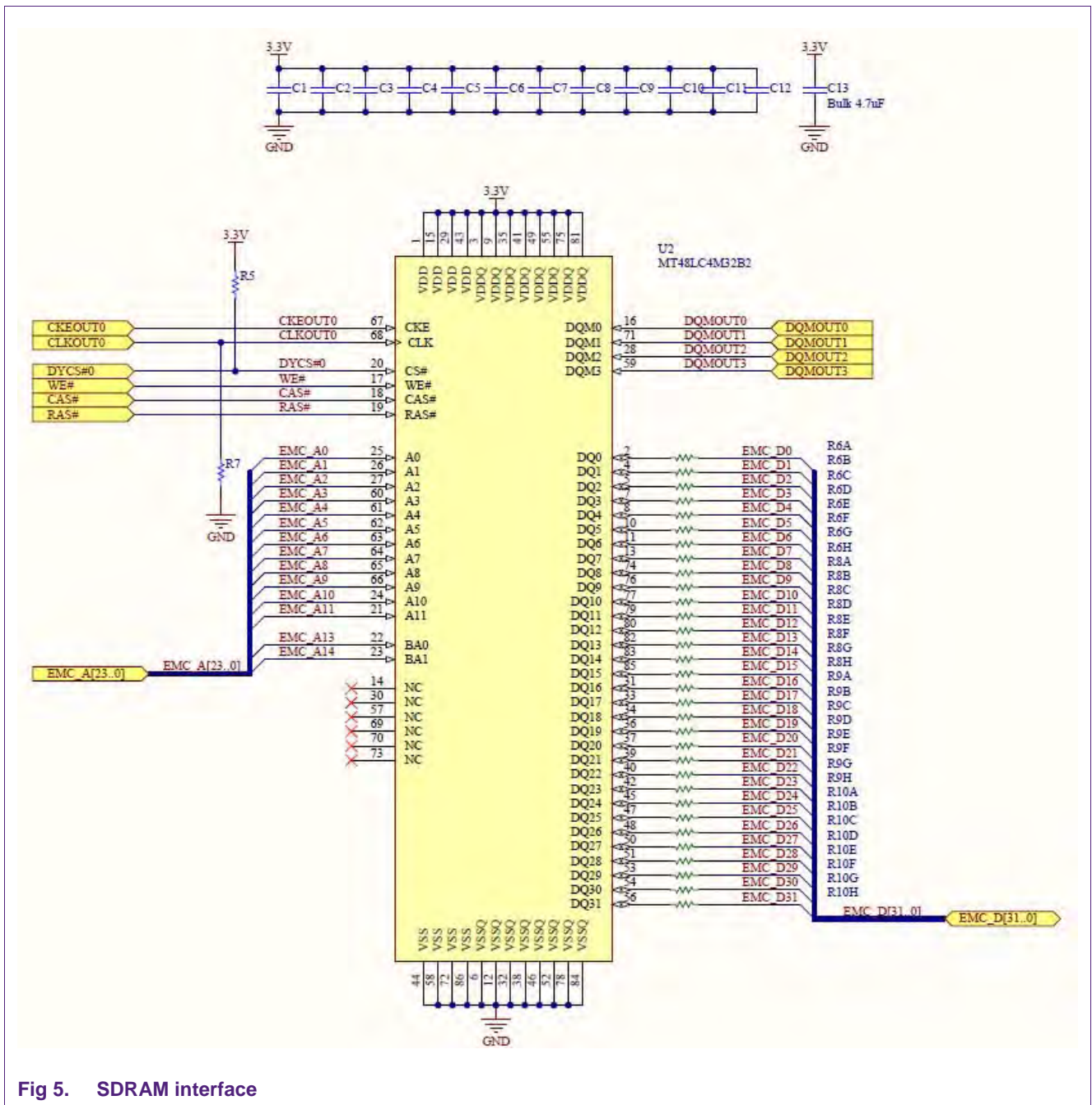

Fig 5. SDRAM interface



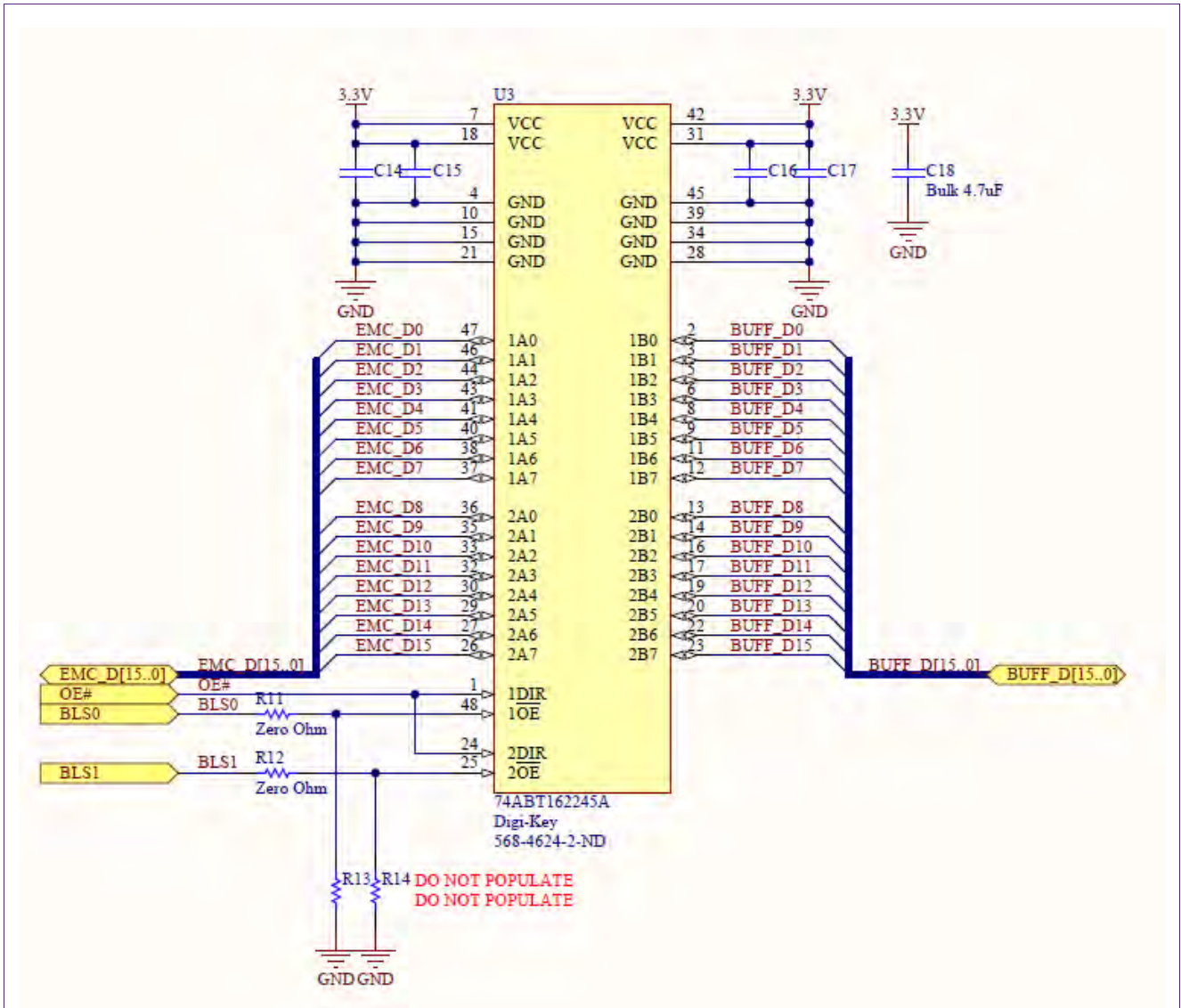

Fig 6. Data[15:0] buffering, BLS[1:0] control output enable

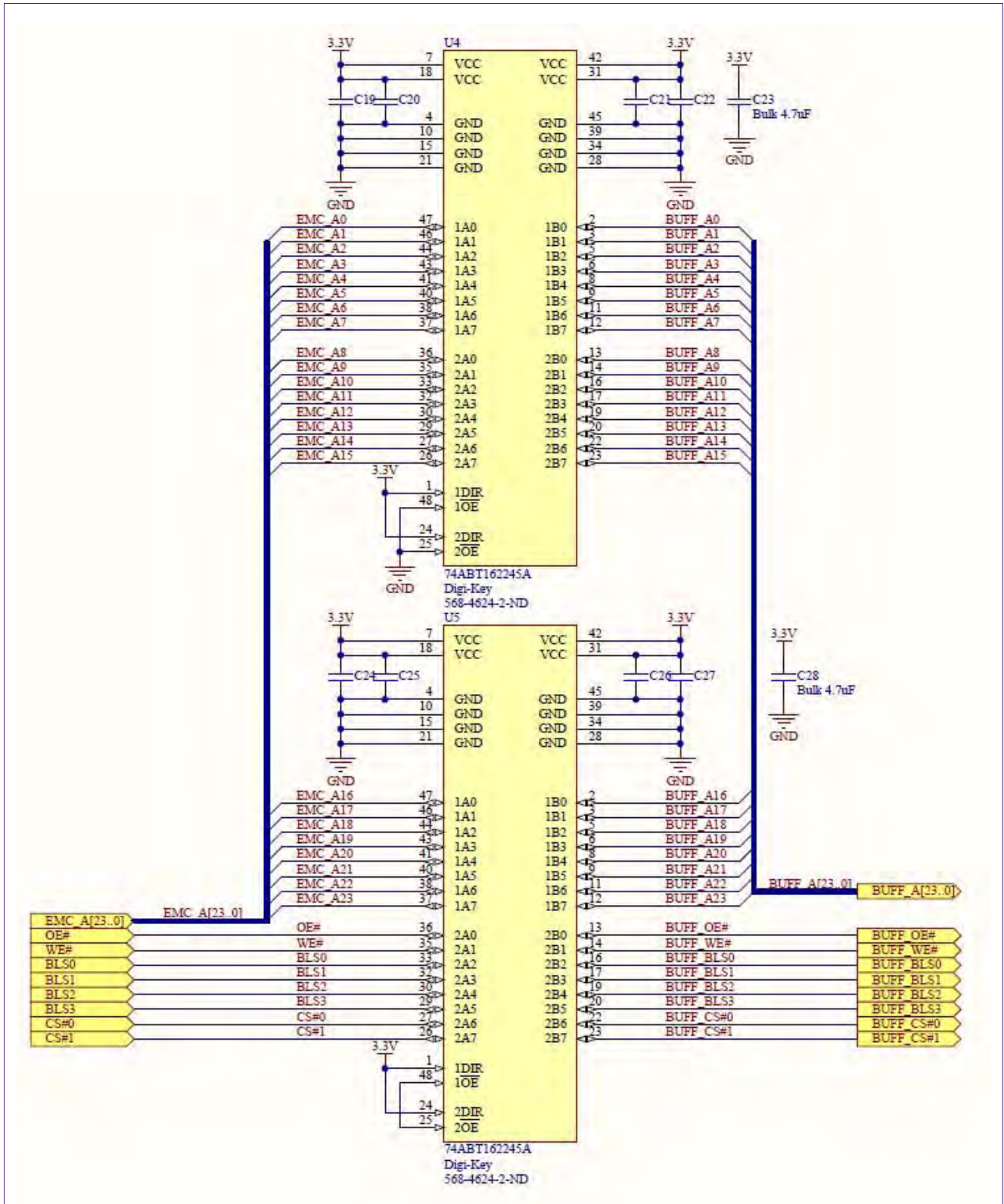

Fig 7. Address[23:0] buffering, static control buffering

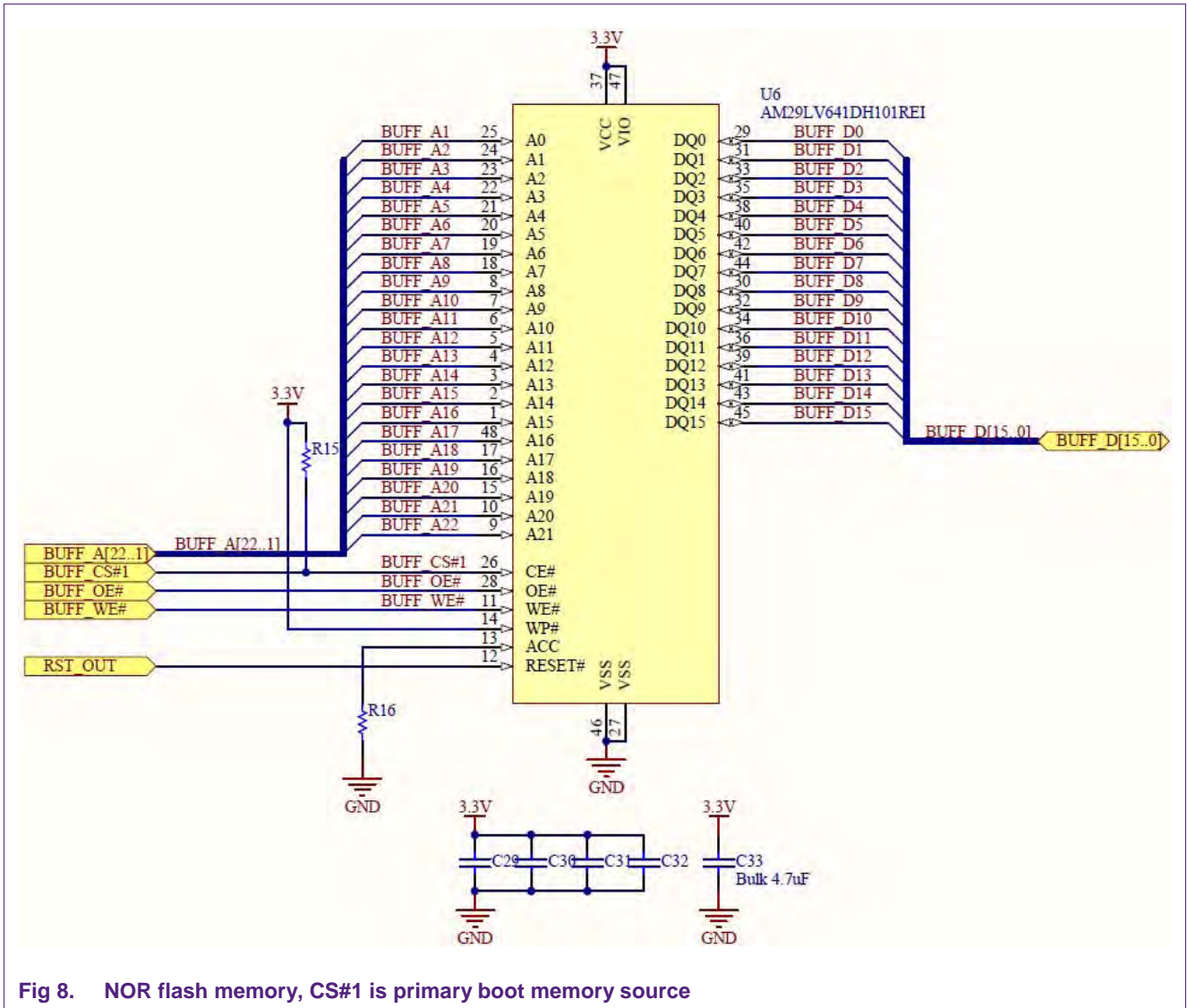

Fig 8. NOR flash memory, CS#1 is primary boot memory source

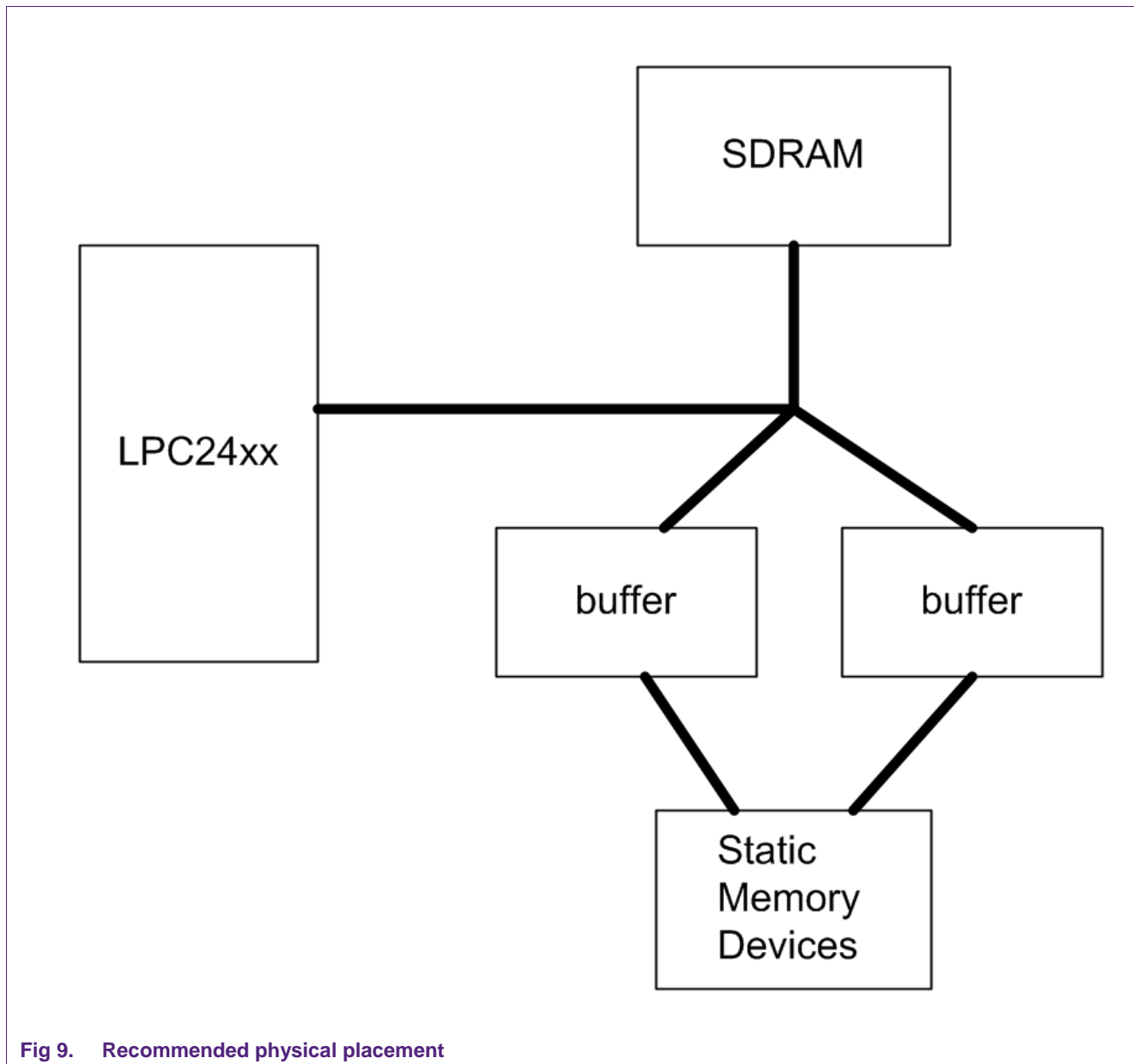

Fig 9. Recommended physical placement

## 8. Conclusion

This example project should illustrate how to properly design a PCB making use of the LPC24XX's external memory bus. Be aware that the design in this application note is relatively simplistic, and more complicated designs will warrant thorough design analysis, with a focus on signal integrity.

Always take care to carefully read the data sheets for all devices on the memory bus, including the LPC24XX's electrical and timing specifications.

By following the design rules included in the application note, designers can avoid many common (and easily corrected) pitfalls which might have otherwise prevented their systems from operating at the maximum system speed.



## 9. Legal information

### 9.1 Definitions

**Draft** — The document is a draft version only. The content is still under internal review and subject to formal approval, which may result in modifications or additions. NXP Semiconductors does not give any representations or warranties as to the accuracy or completeness of information included herein and shall have no liability for the consequences of use of such information.

### 9.2 Disclaimers

**Limited warranty and liability** — Information in this document is believed to be accurate and reliable. However, NXP Semiconductors does not give any representations or warranties, expressed or implied, as to the accuracy or completeness of such information and shall have no liability for the consequences of use of such information. NXP Semiconductors takes no responsibility for the content in this document if provided by an information source outside of NXP Semiconductors.

In no event shall NXP Semiconductors be liable for any indirect, incidental, punitive, special or consequential damages (including - without limitation - lost profits, lost savings, business interruption, costs related to the removal or replacement of any products or rework charges) whether or not such damages are based on tort (including negligence), warranty, breach of contract or any other legal theory.

Notwithstanding any damages that customer might incur for any reason whatsoever, NXP Semiconductors' aggregate and cumulative liability towards customer for the products described herein shall be limited in accordance with the Terms and conditions of commercial sale of NXP Semiconductors.

**Right to make changes** — NXP Semiconductors reserves the right to make changes to information published in this document, including without limitation specifications and product descriptions, at any time and without notice. This document supersedes and replaces all information supplied prior to the publication hereof.

**Suitability for use** — NXP Semiconductors products are not designed, authorized or warranted to be suitable for use in life support, life-critical or safety-critical systems or equipment, nor in applications where failure or malfunction of an NXP Semiconductors product can reasonably be expected to result in personal injury, death or severe property or environmental damage. NXP Semiconductors and its suppliers accept no liability for inclusion and/or use of NXP Semiconductors products in such equipment or applications and therefore such inclusion and/or use is at the customer's own risk.

**Applications** — Applications that are described herein for any of these products are for illustrative purposes only. NXP Semiconductors makes no representation or warranty that such applications will be suitable for the specified use without further testing or modification.

Customers are responsible for the design and operation of their applications and products using NXP Semiconductors products, and NXP Semiconductors accepts no liability for any assistance with applications or customer product design. It is customer's sole responsibility to determine whether the NXP Semiconductors product is suitable and fit for the

customer's applications and products planned, as well as for the planned application and use of customer's third party customer(s). Customers should provide appropriate design and operating safeguards to minimize the risks associated with their applications and products.

NXP Semiconductors does not accept any liability related to any default, damage, costs or problem which is based on any weakness or default in the customer's applications or products, or the application or use by customer's third party customer(s). Customer is responsible for doing all necessary testing for the customer's applications and products using NXP Semiconductors products in order to avoid a default of the applications and the products or of the application or use by customer's third party customer(s). NXP does not accept any liability in this respect.

**Export control** — This document as well as the item(s) described herein may be subject to export control regulations. Export might require a prior authorization from competent authorities.

**Evaluation products** — This product is provided on an "as is" and "with all faults" basis for evaluation purposes only. NXP Semiconductors, its affiliates and their suppliers expressly disclaim all warranties, whether express, implied or statutory, including but not limited to the implied warranties of non-infringement, merchantability and fitness for a particular purpose. The entire risk as to the quality, or arising out of the use or performance, of this product remains with customer.

In no event shall NXP Semiconductors, its affiliates or their suppliers be liable to customer for any special, indirect, consequential, punitive or incidental damages (including without limitation damages for loss of business, business interruption, loss of use, loss of data or information, and the like) arising out of the use of or inability to use the product, whether or not based on tort (including negligence), strict liability, breach of contract, breach of warranty or any other theory, even if advised of the possibility of such damages.

Notwithstanding any damages that customer might incur for any reason whatsoever (including without limitation, all damages referenced above and all direct or general damages), the entire liability of NXP Semiconductors, its affiliates and their suppliers and customer's exclusive remedy for all of the foregoing shall be limited to actual damages incurred by customer based on reasonable reliance up to the greater of the amount actually paid by customer for the product or five dollars (US\$5.00). The foregoing limitations, exclusions and disclaimers shall apply to the maximum extent permitted by applicable law, even if any remedy fails of its essential purpose.

### 9.3 Trademarks

Notice: All referenced brands, product names, service names and trademarks are property of their respective owners.

## 10. Contents

---

<b>1.</b>	<b>Introduction .....</b>	<b>3</b>
<b>2.</b>	<b>Suggestions for achieving peak performance..</b>	<b>3</b>
<b>3.</b>	<b>Suggested design rules .....</b>	<b>4</b>
3.1	General rules.....	4
3.2	Schematic .....	5
3.3	Placement .....	5
3.4	Routing.....	5
<b>4.</b>	<b>Example: Embedded uCLinux (no-MMU support).....</b>	<b>5</b>
<b>5.</b>	<b>Design details .....</b>	<b>5</b>
<b>6.</b>	<b>Example IC bill of materials.....</b>	<b>6</b>
<b>7.</b>	<b>Schematics .....</b>	<b>7</b>
<b>8.</b>	<b>Conclusion.....</b>	<b>15</b>
<b>9.</b>	<b>Legal information .....</b>	<b>16</b>
9.1	Definitions .....	16
9.2	Disclaimers.....	16
9.3	Trademarks.....	16
<b>10.</b>	<b>Contents.....</b>	<b>17</b>

---

Please be aware that important notices concerning this document and the product(s) described herein, have been included in the section 'Legal information'.

---

© NXP B.V. 2012.

All rights reserved.

For more information, please visit: <http://www.nxp.com>  
For sales office addresses, please send an email to: [salesaddresses@nxp.com](mailto:salesaddresses@nxp.com)

Date of release: 9 November 2012

Document identifier: AN10950