

Calibration-Free Pressure Sensor System

by: Michel Burri, Senior System Engineer
Geneva, Switzerland

INTRODUCTION

The MPX2000 series pressure transducers are semiconductor devices which give an electrical output signal proportional to the applied pressure. The sensors are a single monolithic silicon diaphragm with strain gauge and thin-film resistor networks on the chip. Each chip is laser trimmed for full scale output, offset, and temperature compensation.

The purpose of this document is to describe another method of measurement which should facilitate the life of the design. The MPX2000 series sensors are available both as unported elements and as ported assemblies suitable for pressure, vacuum and differential pressure measurements in the range of 10 kPa through 200 kPa.

The use of the on-chip A/D converter of the MC68HC05B6 HCMOS MCU makes possible the design of an accurate and reliable pressure measurement system.

SYSTEM ANALYSIS

The measurement system is made up of the pressure sensor, the amplifiers, and the MCU. Each element in the chain has its own device-to-device variations and temperature effects which should be analyzed separately. For instance, the 8-bit A/D converter has a quantization error of about ± 0.2 percent. This error should be subtracted from the maximum error specified for the system to find the available error for the rest of elements in the chain. The MPX2000 series pressure sensors are designed to provide an output sensitivity of 4.0 mV/V excitation voltage with full-scale pressure applied or 20 mV at the excitation voltage of 5.0 V_{DC} .

An interesting property must be considered to define the configuration of the system: the ratiometric function of both the A/D converter and the pressure sensor device. The ratiometric function of these elements makes all voltage variations from the power supply rejected by the system. With this advantage, it is possible to design a chain of amplification where the signal is conditioned in a different way.

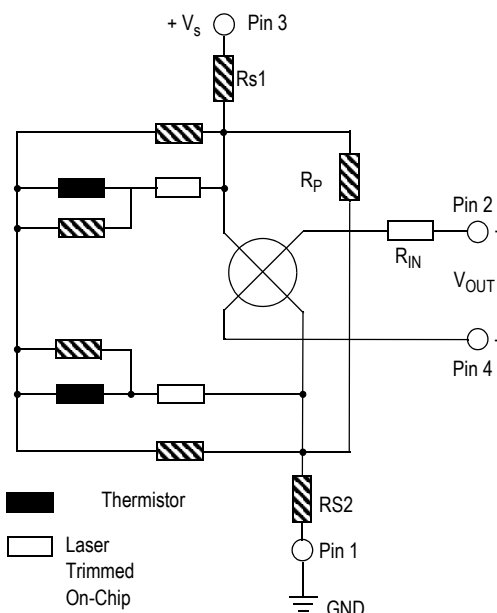

Figure 1. Seven Laser-Trimmed Resistors and Two Thermistors Calibrate the Sensor for Offset, Span, Symmetry and Temperature Compensation

The op amp configuration should have a good common-mode rejection ratio to cancel the DC component voltage of the pressure sensor element which is about half the excitation voltage value V_S . Also, the op amp configuration is important when the designer's objective is to minimize the calibration procedures which cost time and money and often don't allow the unit-to-unit replacement of devices or modules.

One other aspect is that most of the applications are not affected by inaccuracy in the region from 0 kPa to 40 kPa. Therefore, the goal is to obtain an acceptable tolerance of the system from 40 kPa through 100 kPa, thus minimizing the inherent offset voltage of the pressure sensor.

PRESSURE SENSOR CHARACTERISTICS

Figure 2 shows the differential output voltage of the MPX2100 series at +25°C. The dispersion of the output voltage determines the best tolerance that the system may

achieve without undertaking a calibration procedure, if any other elements or parameters in the chain do not introduce additional errors.

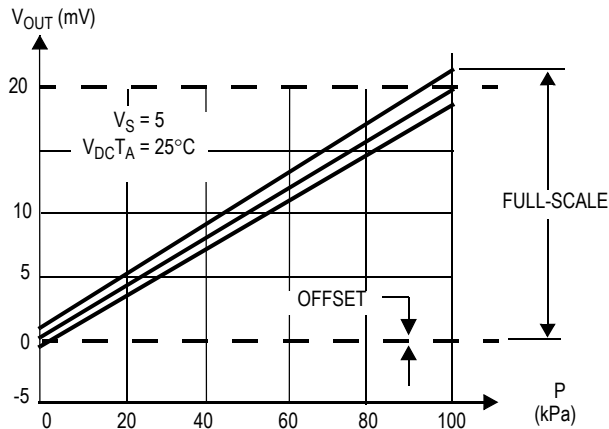

Figure 2. Spread of the Output Voltage versus the Applied Pressure at 25°C

The effects of temperature on the full scale output and offset are shown in Figure 3. It is interesting to notice that the offset variation is greater than the full scale output and both have a positive temperature coefficient respectively of +8.0 $\mu\text{V}/\text{degree}$ and +5.0 μV excitation voltage. That means that the full scale variation may be compensated by modifying the gain somewhere in the chain amplifier by components arranged to produce a negative T_C of 250 PPM/ $^{\circ}\text{C}$. The dark area of Figure 3 shows the trend of the compensation which improves the full scale value over the temperature range. In the area of 40 kPa, the compensation acts in the ratio of 40/100 of the value of the offset temperature coefficient.

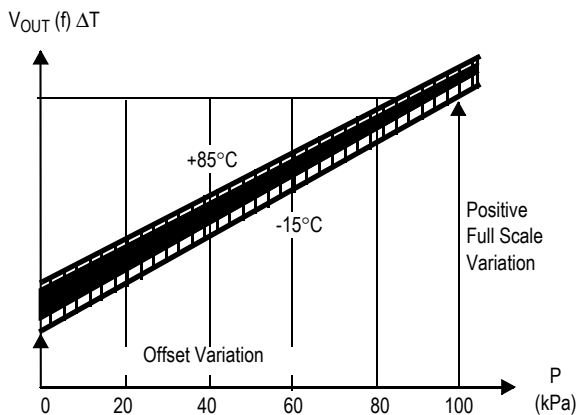

Figure 3. Output Voltage versus Temperature. The Dark Area Shows the Trend of the Compensation

OP AMP CHARACTERISTICS

For systems with only one power supply, the instrument amplifier configuration shown in Figure 4 is a good solution to monitor the output of a resistive transducer bridge.

The instrument amplifier does provide an excellent CMRR and a symmetrical buffered high input impedance at both non-inverting and inverting terminals. It minimizes the number of the external passive components used to set the gain of the amplifier. Also, it is easy to compensate the temperature variation of the Full Scale Output of the Pressure Sensor by implementing resistors " R_f " having a negative coefficient temperature of -250 PPM/ $^{\circ}\text{C}$.

The differential-mode voltage gain of the instrument amplifier is:

$$A_{vd} = \frac{V1-V2}{V_{s2}-V_{s4}} = \left(1 + \frac{2 R_f}{R_g}\right) \quad (1)$$

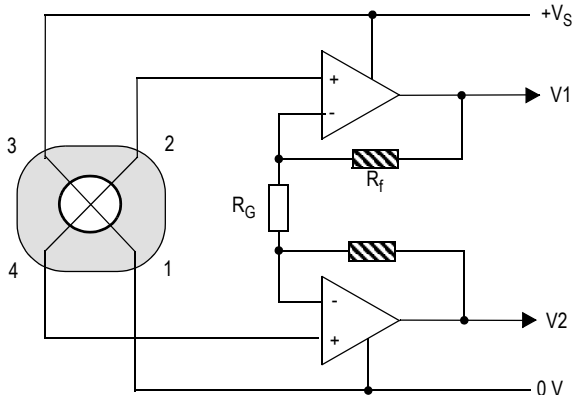

Figure 4. One Power Supply to Excite the Bridge and to Develop a Differential Output Voltage

The major source of errors introduced by the op amp is offset voltages which may be positive or negative, and the input bias current which develops a drop voltage ΔV through the feedback resistance R_f . When the op amp input is composed of PNP transistors, the whole characteristic of the transfer function is shifted below the DC component voltage value set by the Pressure Sensor as shown in Figure 5.

The gain of the instrument amplifier is calculated carefully to avoid a saturation of the output voltage, and to provide the maximum of differential output voltage available for the A/D Converter. The maximum output swing voltage of the amplifiers is also dependent on the bias current which creates a ΔV voltage on the feedback resistance R_f and on the Full Scale output voltage of the pressure sensor.

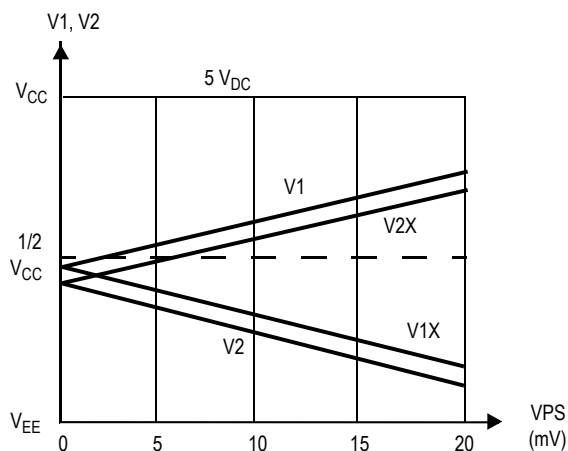

Figure 5. Instrument Amplifier Transfer Function with Spread of the Device to Device Offset Variation

Figure 5 shows the transfer function of different instrument amplifiers used in the same application. The same sort of random errors are generated by crossing the inputs of the instrument amplifier. The spread of the differential output voltage ($V1-V2$) and ($V2x-V1x$) is due to the unsigned voltage offset and its absolute value. Figure 6 and Figure 7 show the unit-to-unit variations of both the offset and the bias current of the dual op amp MC33078.

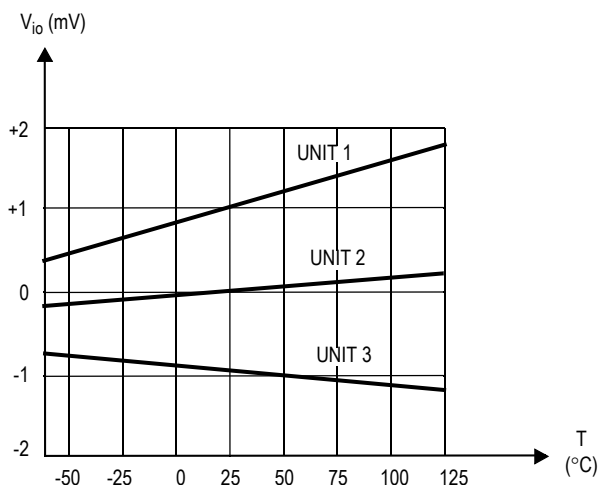

Figure 6. Input Offset Voltage versus Temperature

To realize such a system, the designer must provide a calibration procedure which is very time consuming. Some extra potentiometers must be implemented for setting both the offset and the Full Scale Output with a complex temperature compensation network circuit.

The new proposed solution will reduce or eliminate any calibration procedure.

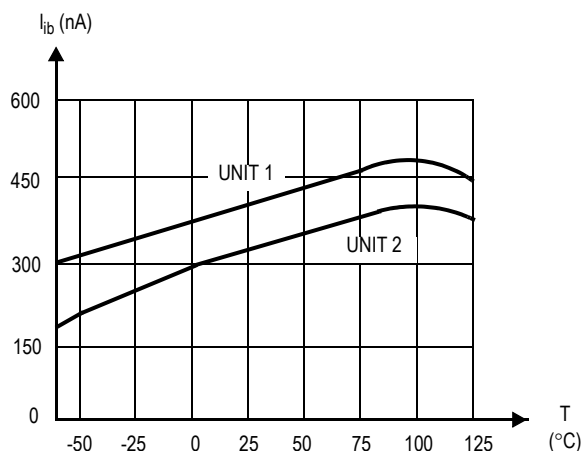

Figure 7. Input Bias Current versus Temperature

MCU CONTRIBUTION

As shown in Figure 5, crossing the instrument amplifier inputs generated their mutual differences which can be computed by the MCU.

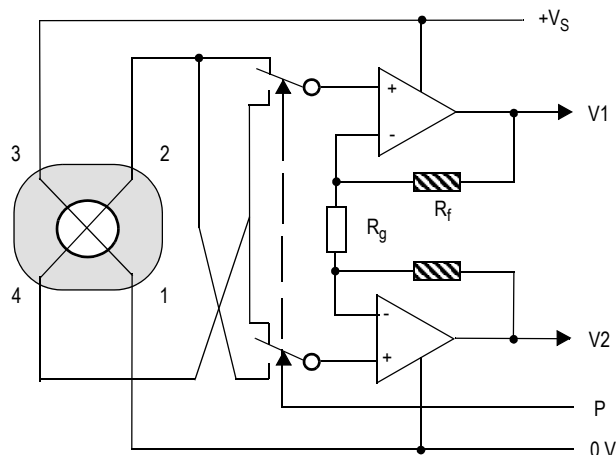

Figure 8. Crossing of the Instrument Amplifier Input Using a Port of the MCU

Figure 8 shows the analog switches on the front of the instrument amplifier and the total symmetry of the chain. The residual resistance $R_{DS(on)}$ of the switches does not introduce errors due to the high input impedance of the instrument amplifier.

With the aid of two analog switches, the MCU successively converts the output signals $V1$, $V2$.

Four conversions are necessary to compute the final result. First, two conversions of $V1$ and $V2$ are executed and stored in the registers $R1$, $R2$. Then, the analog switches are commuted in the opposite position and the two last conversions of $V2_x$ and $V1_x$ are executed and stored in the registers $R2_x$ and $R1_x$. Then, the MCU computes the following equation:

$$\text{RESULT} = (R1-R2) + (R2x-R1x) \quad (2)$$

The result is twice a differential conversion. As demonstrated below, all errors from the instrument amplifier

are cancelled. Other averaging techniques may be used to improve the result, but the appropriated algorithm is always determined by the maximum bandwidth of the input signal and the required accuracy of the system.

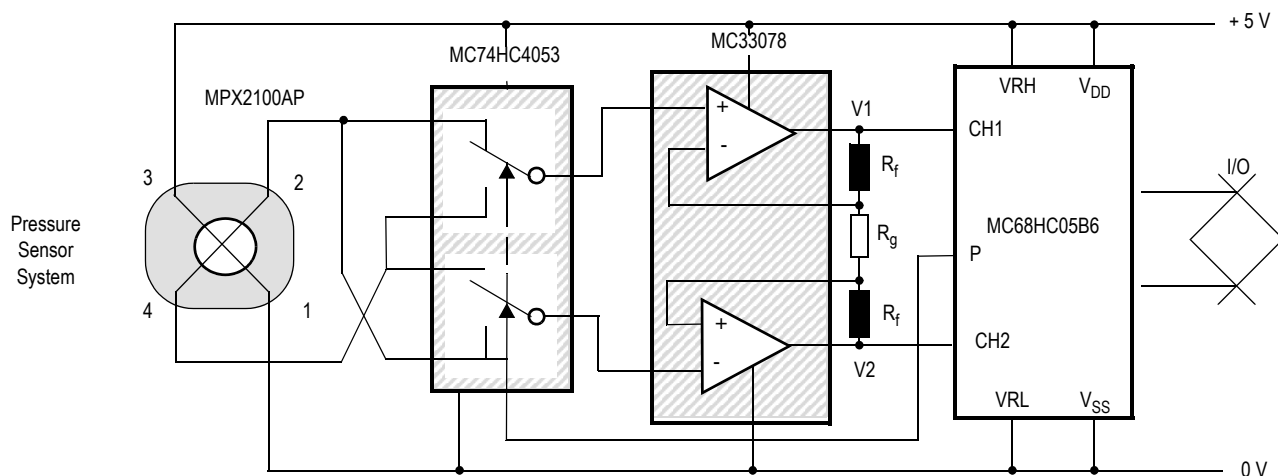

Figure 9. Two Channel Input and One Output Port Are Used by the MCU

SYSTEM CALCULATION

Sensor out 2
 $Vs2 = a(P) + of2$

Sensor out 4
 $Vs4 = b(P) + of4$

Amplifier out 1
 $V1 = Avd(Vs2 + OF1)$

Amplifier out 2
 $V2 = Avd(Vs4 + OF2)$

Inverting of the amplifier input
 $V1x = Avd(Vs4 + OF1)$ $V2x = Avd(Vs2 + OF2)$

Delta = $V1 - V2$ 1st differential result
 $= Avd * (Vs2 + OF1) - Avd * (Vs4 + OF2)$

Deltax = $V2x - V1x$ 2nd differential result
 $= Avd * (Vs2 + OF2) - Avd * (Vs4 + OF1)$

Adding of the two differential results

$$\begin{aligned} VoutV &= \text{Delta} + \text{Deltax} \\ &= Avd * Vs2 + Avd * OF2 + Avd * OF2 - Avd * OF1 \\ &\quad + Avd * OF1 - Avd * OF2 + Avd * OF2 - Avd * OF1 \\ &= 2 * Avd * (Vs2 - Vs4) \\ &= 2 * Avd * [(a(P) + of2) - (b(P) + of4)] \\ &= 2 * Avd * [V(P) + Voffset] \end{aligned}$$

There is a full cancellation of the amplifier offset OF1 and OF2. The addition of the two differential results V1-V2 and V2x-V1x produce a virtual output voltage VoutV which becomes the applied input voltage to the A/D converter. The result of the conversion is expressed in the number of counts or bits by the ratiometric formula shown below:

$$\text{count} = VoutV * \frac{255}{VRH - VRL}$$

255 is the maximum number of counts provided by the A/D converter and VRH-VRL is the reference voltage of the ratiometric A/D converter which is commonly tied to the 5.0 V supply voltage of the MCU.

When the tolerance of the full scale pressure has to be in the range of ± 2.5 percent, the offset of the pressure sensor may be neglected. That means the system does not require any calibration procedure.

The equation of the system transfer is then:

$$\text{count} = 2 * Avd * V(P) * 51/V \text{ where:}$$

Avd is the differential-mode gain of the instrument amplifier which is calculated using the equation (1). Then with $R_f = 510 \text{ k}\Omega$ and $R_g = 9.1 \text{ k}\Omega$ $Avd = 113$.

The maximum counts available in the MCU register at the Full Scale Pressure is:

$$\text{count (Full Scale)} = 2 * 113 * 0.02 \text{ V} * 51/V = 230$$

knowing that the MPX2100AP pressure sensor provides 20 mV at 5.0 excitation voltage and 100 kPa full scale pressure.

The system resolution is 100 kPa/230 that give 0.43 kPa per count.

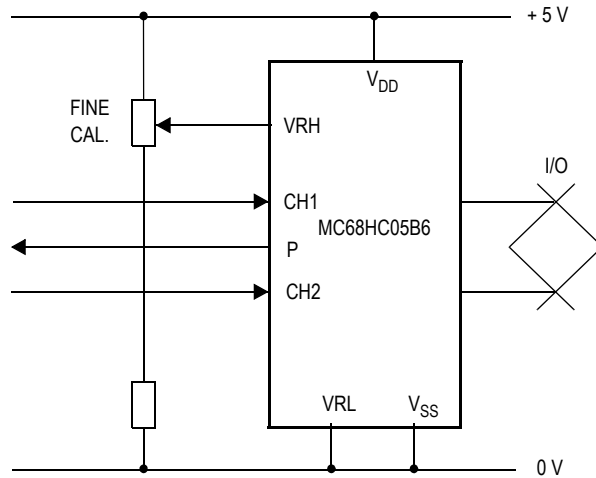

Figure 10. Full Scale Output Calibration Using the Reference Voltage VRH-VRL

When the tolerance of the system has to be in the range of ± 1 percent, the designer should provide only one calibration

procedure which sets the Full Scale Output (counts) at 25°C 100 kPa or under the local atmospheric pressure conditions.

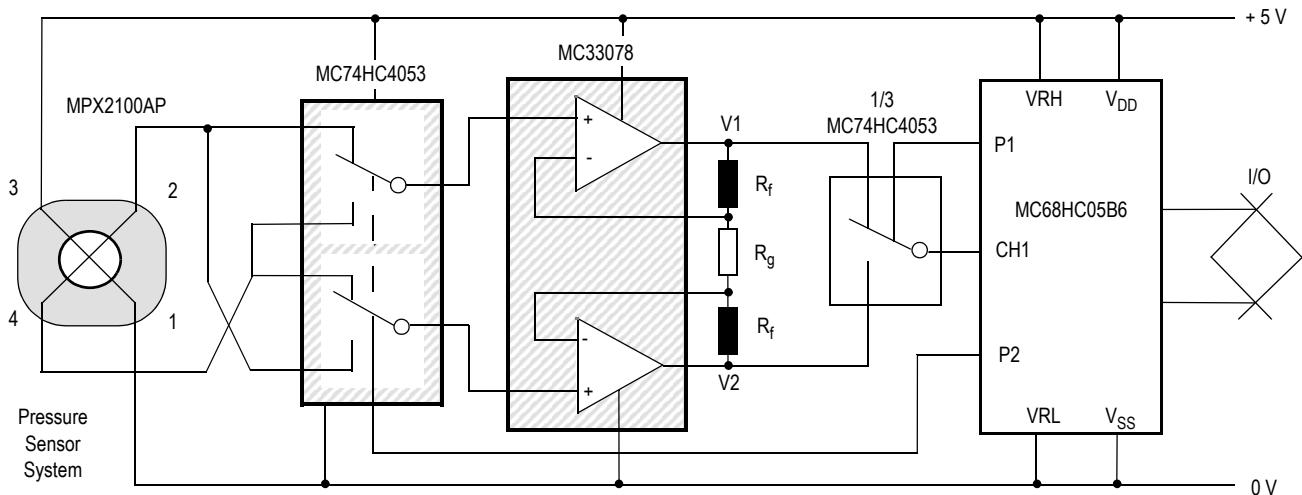

Figure 11. One Channel Input and Two Output Ports are used by the MCU

Due to the high impedance input of the A/D converter of the MC68HC05B6 MCU, another configuration may be implemented which uses only one channel input as shown in Figure 11. It is interesting to notice that practically any dual op amp may be used to do the job but a global consideration must be made to optimize the total cost of the system according to the requested specification.

When the Full Scale Pressure has to be sent with accuracy, the calibration procedure may be executed in different ways. For instance, the module may be calibrated directly using Up/Down push buttons.

The gain of the chain is set by changing the VRH voltage of the ratiometric A/D converter with the R/2R ladder network circuit which is directly driven by the ports of the MCU. (See Figure 12.)

Using a communication bus, the calibration procedure may be executed from a host computer. In both cases, the setting value is stored in the EEPROM of the MCU.

The gain may be also set using a potentiometer in place of the resistor R_f . But, this component is expensive, taking into account that it must be stable over the temperature range at long term.

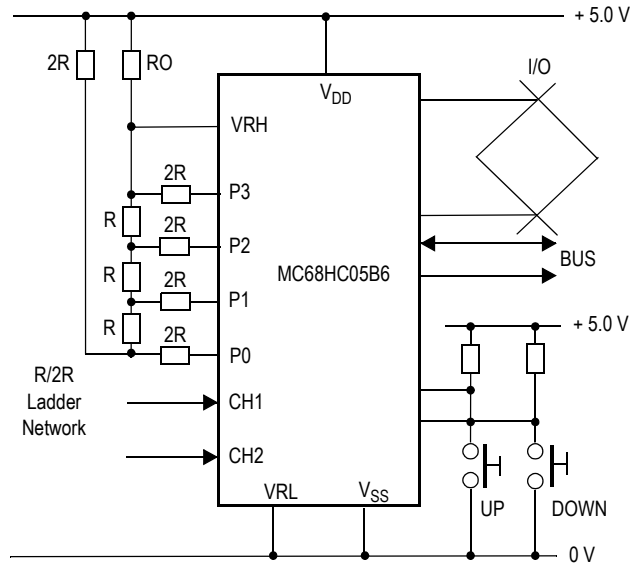

Figure 12. R/2R Ladder Network for an MCU

Table 1. Pressure Conversion Table

Unity	Pa	mbar	Torr	atm	at=kp/cm ²	mWS	psi
1 N/m ² = 1 Pascal	1	0.01	7.5 10 ⁻³	-	-	-	-
1 mbar	100	1	0.75	-	-	0.0102	0.014
1 Torr = 1 mmHg	133.32	1.333	.1	-	-	-	0.019
1 atm ⁽¹⁾	101325	1013.2	760	1	1.033	10.33	14.69
1 at = 1 kp/cm ² ⁽²⁾	98066.5	981	735.6	0.97	1	10	14.22
1 m of water	9806.65	98.1	73.56	0.097	0.1	1	1.422
1 lb/sqin = 1 psi	6894.8	68.95	51.71	0.068	-	-	1

NOTES:

1. Normal atmosphere
2. Technical atmosphere

NOTES

How to Reach Us:

Home Page:
www.freescale.com

E-mail:
support@freescale.com

USA/Europe or Locations Not Listed:
Freescale Semiconductor
Technical Information Center, CH370
1300 N. Alma School Road
Chandler, Arizona 85224
+1-800-521-6274 or +1-480-768-2130
support@freescale.com

Europe, Middle East, and Africa:
Freescale Halbleiter Deutschland GmbH
Technical Information Center
Schatzbogen 7
81829 Muenchen, Germany
+44 1296 380 456 (English)
+46 8 52200080 (English)
+49 89 92103 559 (German)
+33 1 69 35 48 48 (French)
support@freescale.com

Japan:
Freescale Semiconductor Japan Ltd.
Headquarters
ARCO Tower 15F
1-8-1, Shimo-Meguro, Meguro-ku,
Tokyo 153-0064
Japan
0120 191014 or +81 3 5437 9125
support.japan@freescale.com

Asia/Pacific:
Freescale Semiconductor Hong Kong Ltd.
Technical Information Center
2 Dai King Street
Tai Po Industrial Estate
Tai Po, N.T., Hong Kong
+800 2666 8080
support.asia@freescale.com

For Literature Requests Only:
Freescale Semiconductor Literature Distribution Center
P.O. Box 5405
Denver, Colorado 80217
1-800-441-2447 or 303-675-2140
Fax: 303-675-2150
LDCForFreescaleSemiconductor@hibbertgroup.com

Information in this document is provided solely to enable system and software implementers to use Freescale Semiconductor products. There are no express or implied copyright licenses granted hereunder to design or fabricate any integrated circuits or integrated circuits based on the information in this document.

Freescale Semiconductor reserves the right to make changes without further notice to any products herein. Freescale Semiconductor makes no warranty, representation or guarantee regarding the suitability of its products for any particular purpose, nor does Freescale Semiconductor assume any liability arising out of the application or use of any product or circuit, and specifically disclaims any and all liability, including without limitation consequential or incidental damages. "Typical" parameters that may be provided in Freescale Semiconductor data sheets and/or specifications can and do vary in different applications and actual performance may vary over time. All operating parameters, including "Typicals", must be validated for each customer application by customer's technical experts. Freescale Semiconductor does not convey any license under its patent rights nor the rights of others. Freescale Semiconductor products are not designed, intended, or authorized for use as components in systems intended for surgical implant into the body, or other applications intended to support or sustain life, or for any other application in which the failure of the Freescale Semiconductor product could create a situation where personal injury or death may occur. Should Buyer purchase or use Freescale Semiconductor products for any such unintended or unauthorized application, Buyer shall indemnify and hold Freescale Semiconductor and its officers, employees, subsidiaries, affiliates, and distributors harmless against all claims, costs, damages, and expenses, and reasonable attorney fees arising out of, directly or indirectly, any claim of personal injury or death associated with such unintended or unauthorized use, even if such claim alleges that Freescale Semiconductor was negligent regarding the design or manufacture of the part.

Freescale™ and the Freescale logo are trademarks of Freescale Semiconductor, Inc. All other product or service names are the property of their respective owners.

© Freescale Semiconductor, Inc. 2005. All rights reserved.