

# Analog to Digital Converter Resolution Extension Using a Pressure Sensor

## PURPOSE

This paper describes a simple method to gain more than 8-bits of resolution with an 8-bit A/D. The electronic design is relatively simple and uses standard components.

## Principle

Consider a requirement to measure pressure up to 200kPa. Using a pressure sensor and an amplifier, this pressure can be converted to an analog voltage output. This analog voltage can then be converted to a digital value and used by the microprocessor as shown in [Figure 1](#).

If we assume for this circuit that 200 kPa results in a +4.5V output, the sensitivity of our system is: /

$$\begin{aligned} S &= 4.5 \text{ V}/200\text{kPa} & (1) \\ &= 0.0225 \text{ V/kPa} \\ \text{or } S &= 22.5 \text{ mV/kPa} \end{aligned}$$

If an 8-bit A/D is used with 0 and 5 Volt low and high references, respectively, then the resolution would be:

$$\begin{aligned} S &= 5 \text{ V}/(2^8 - 1 = 255) & (2) \\ &= 0.01961 \text{ V} \\ \text{or } R_v &= 19.60 \text{ mV per bit} \end{aligned}$$

This corresponds to a pressure resolution of:

$$\begin{aligned} R_p &= 5 \text{ V}/(19.60 \text{ mV/bit}) / (22.5 \text{ mV/kPa}) & (3) \\ &= 0.871 \text{ kPa per bit} \end{aligned}$$

Assume a resolution of at least 0.1 kPa/bit is needed. This would require an A/D with at least 12 bits ( $2^{12} = 4096$  steps).

One can artificially increase the A/D resolution as described below.

Refer to [Figure 1](#) and assume a pressure of 124 kPa is to be measured. With this system, the input signal to the A/D should read (assuming no offset voltage error):

$$\begin{aligned} V_{m(\text{measured})} &= 4.5 (P_{\text{app}}) \times (S) & (4) \\ &= (124 \text{ kPa}) \times (22.5 \text{ mV/kPa}) \\ &= 2790 \text{ mV}, \end{aligned}$$

where  $P_{\text{app}}$  is the pressure applied to the sensor.

Due to the resolution of the A/D, the microprocessor receives the following conversion:

$$\begin{aligned} M &= (2790 \text{ mV}) / (19.60 \text{ mV/bit}) & (5) \\ &= 142.35 \\ &= 142 \text{ (truncated to integer)} \end{aligned}$$

The calculated voltage for this stored value is:

$$\begin{aligned} V_c(\text{calculated}) &= (142 \text{ count}) \times (19.60\text{mV/count}) & (6) \\ &= 2783 \text{ mV} \end{aligned}$$

The microprocessor will output the stored value  $M$  to the D/A. The corresponding voltage at the analog output of the D/A, for an 8-bit D/A with same references, will be 2783 mV.

The calculated pressure corresponding to this voltage would be:

$$\begin{aligned} P_c(\text{calculated}) &= (2783 \text{ mV}) / (22.5 \text{ mV/kPa}) & (7) \\ &= 123.7 \text{ kPa} \end{aligned}$$

Thus, the error would be:

$$\begin{aligned} E &= P_{\text{app}} - P_c & (8) \\ &= 124 \text{ kPa} - 123.7 \text{ kPa} \\ &= 0.3 \text{ kPa} \end{aligned}$$

This is greater than the 0.1 kPa resolution requirement.

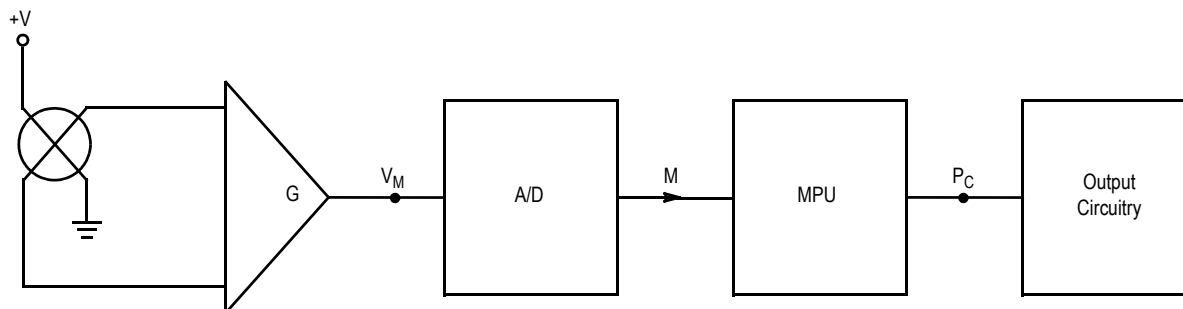
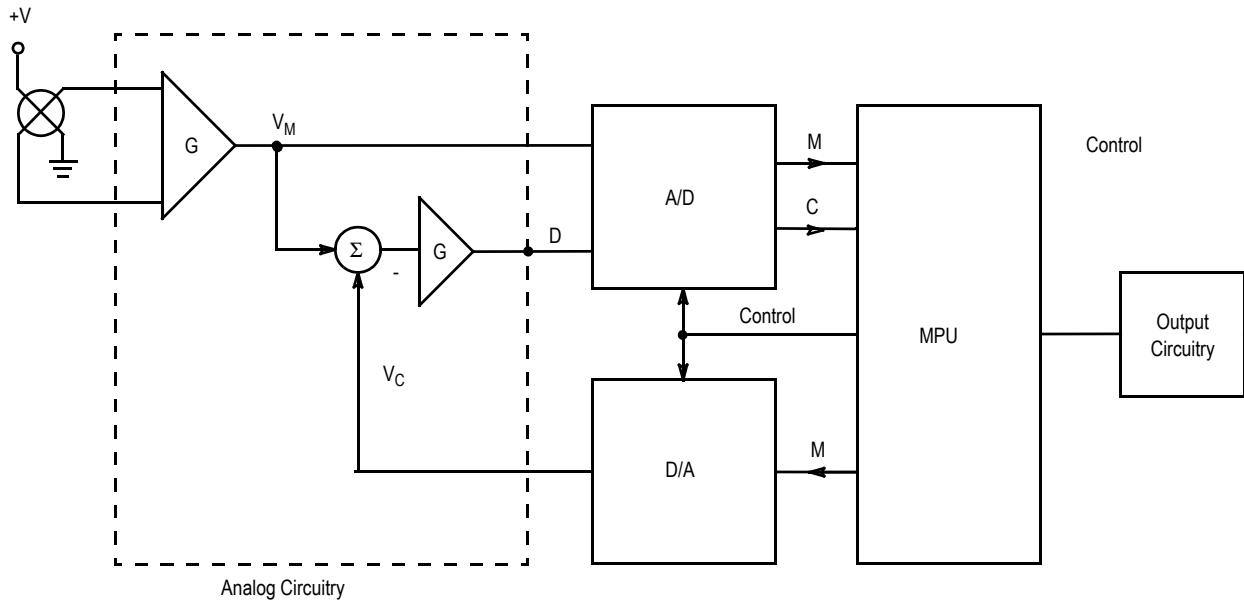

Figure 1. Figure Block Diagram



**Figure 2. Expanded Block Diagram**

Figure 2 shows the block diagram of a system that can be used to reduce the inaccuracies caused by the limited A/D resolution. The microprocessor would use the stored value M, as described above, to cause a D/A to output the corresponding voltage, V<sub>C</sub>. V<sub>C</sub> is subtracted from the measured voltage, V<sub>M</sub>, using a differential amplifier, and the resulting voltage is amplified. Assuming a gain, G, of 10 for the amplifier, the output would be:

$$\begin{aligned}
 D &= (V_M - V_C) \times G & (9) \\
 &= (2790 \text{ mV} - 2783 \text{ mV}) \times 10 \\
 &= 70 \text{ mV}
 \end{aligned}$$

The microprocessor will receive the following count from the A/D:

$$\begin{aligned}
 C &= 70 \text{ mV} / (19.60 \text{ mV/count}) & (10) \\
 &= 3.6 \\
 &= 3 \text{ full counts}
 \end{aligned}$$

The microprocessor then computes the actual pressure with the following equations:

$$\begin{aligned}
 \text{Expanded Voltage} &= V_C + ((C \times R) / G) & (11) \\
 &= 2783 + ((3 \times 19.60) / 10) \\
 &= 2789 \text{ mV},
 \end{aligned}$$

NOTE: R is resolution of 8-bit d/A

$$\begin{aligned}
 \text{Corresponding Pressure} &= 2789 \text{ mV} / & (12) \\
 &= 22.5 \text{ mV/kPa} \\
 &= 123.9 \text{ kPa}
 \end{aligned}$$

Thus the error is:

$$\begin{aligned}
 \text{Pressure Error} &= \text{Actual} - \text{Measured} & (13) \\
 &= 124 \text{ kPa} - 123.9 \text{ kPa} \\
 &= 0.1 \text{ kPa}
 \end{aligned}$$

Figure 3 and Figure 4 together provide a more detailed description of the analog portion of this system.

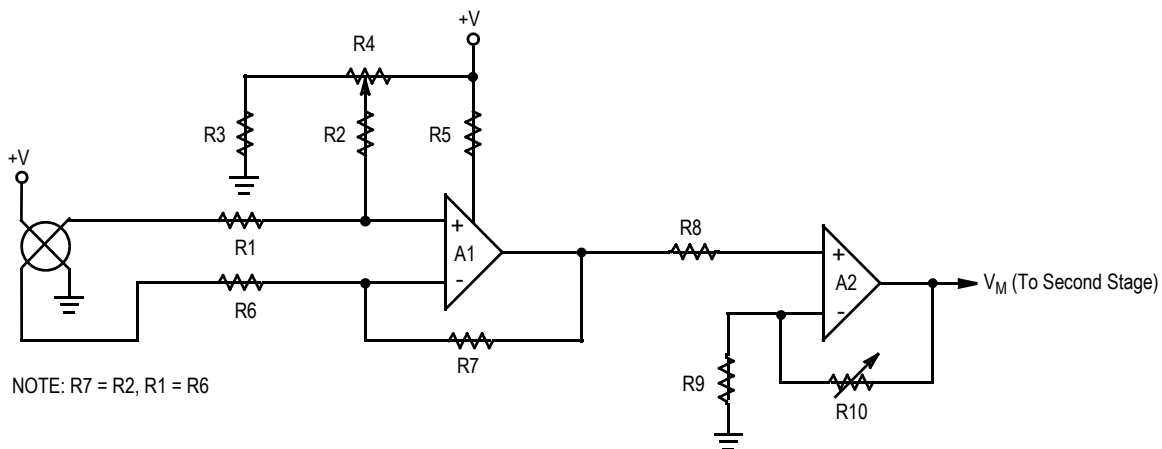

NOTE: R<sub>7</sub> = R<sub>2</sub>, R<sub>1</sub> = R<sub>6</sub>

**Figure 3. First Stage - Differential Amplifier, Offset Adjust and Gain Adjust**

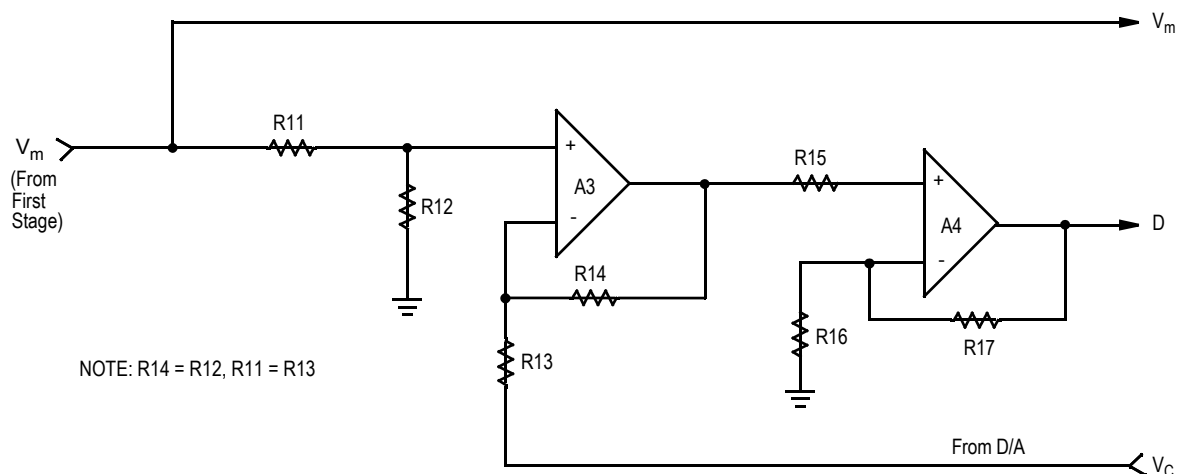

**Figure 4. Second Stage - Difference Amplifier and Gains**

### FIRST STAGE (FIGURE 3)

The first stage consists of the pressure sensor; in this case the MPX2200 is used. This sensor typically gives a full scale span output of 40 mV at 200 kPa. The sensor output ( $V_s$ ) is connected to the inputs of amplifier A1 (1/4 of the MC33079, a Quad Operational Amplifier). The gain,  $G_1$ , of this amplifier is  $R_7/R_6$ . The sensor has a typical zero pressure offset voltage of 1 mV. Figure 3 shows offset compensation circuitry if it is needed. A1 output is fed to the non-inverting input of A2 amplifier (1/4 of a MC33079) whose gain,  $G_2$ , is  $1+R_{10}/R_9$ .  $G_2$  should be set to yield 4.5 volts out with full-rated pressure.

### THE SECOND STAGE (FIGURE 4)

The output from A2 ( $V_m = G_1 \times G_2 \times V_s$ ) is connected to the non-inverting input of amplifier A3 (1/4 of a MC33079) and to the A/D where its corresponding (digital) value is stored by the microprocessor. The output of A3 is the amplified difference between  $V_m$ , and the digitized/calculated voltage  $V_c$ . Amplifier A4 (1/4 of a MC33079) provides additional gain for an amplified difference output for the desired resolution. This difference output,  $D$ , is given by:

$$D = (V_m - V_c) \times G_3$$

$$G_3 = (R_{14}/R_{13}) \left( 1 + \frac{R_{17}}{R_{16}} \right)$$

where  $G_3$  is the gain associated with amplifiers A3 and A4.

The theoretical resolution is limited only by the accuracy of the programmable power supply. The microprocessor used has an integrated A/D. The accuracy of this A/D is directly related to the reference voltage source stability, which can be self-calibrated by the microprocessor.  $V_{expanded}$  is the system output that is the sum of the voltage due to the count and the voltage due to the difference between the count voltage and the measured voltage. This is given by the following relation:

$$V_{expanded} = V_c + D/G_3$$

therefore,  $PV_{expanded} = V_{expanded}/S$ .

$P_{expanded}$  is the value of pressure (in units of kPa) that results from this improved-resolution system. This value can be output to a display or used for further processing in a control system.

### CONCLUSION

This circuit provides an easy way to have high resolution using inexpensive microprocessors and converters.

## **How to Reach Us:**

### **Home Page:**

[www.freescale.com](http://www.freescale.com)

### **E-mail:**

[support@freescale.com](mailto:support@freescale.com)

### **USA/Europe or Locations Not Listed:**

Freescale Semiconductor  
Technical Information Center, CH370  
1300 N. Alma School Road  
Chandler, Arizona 85224  
+1-800-521-6274 or +1-480-768-2130  
[support@freescale.com](mailto:support@freescale.com)

### **Europe, Middle East, and Africa:**

Freescale Halbleiter Deutschland GmbH  
Technical Information Center  
Schatzbogen 7  
81829 Muenchen, Germany  
+44 1296 380 456 (English)  
+46 8 52200080 (English)  
+49 89 92103 559 (German)  
+33 1 69 35 48 48 (French)  
[support@freescale.com](mailto:support@freescale.com)

### **Japan:**

Freescale Semiconductor Japan Ltd.  
Headquarters  
ARCO Tower 15F  
1-8-1, Shimo-Meguro, Meguro-ku,  
Tokyo 153-0064  
Japan  
0120 191014 or +81 3 5437 9125  
[support.japan@freescale.com](mailto:support.japan@freescale.com)

### **Asia/Pacific:**

Freescale Semiconductor Hong Kong Ltd.  
Technical Information Center  
2 Dai King Street  
Tai Po Industrial Estate  
Tai Po, N.T., Hong Kong  
+800 2666 8080  
[support.asia@freescale.com](mailto:support.asia@freescale.com)

### **For Literature Requests Only:**

Freescale Semiconductor Literature Distribution Center  
P.O. Box 5405  
Denver, Colorado 80217  
1-800-441-2447 or 303-675-2140  
Fax: 303-675-2150  
[LDCForFreescaleSemiconductor@hibbertgroup.com](mailto:LDCForFreescaleSemiconductor@hibbertgroup.com)

Information in this document is provided solely to enable system and software implementers to use Freescale Semiconductor products. There are no express or implied copyright licenses granted hereunder to design or fabricate any integrated circuits or integrated circuits based on the information in this document.

Freescale Semiconductor reserves the right to make changes without further notice to any products herein. Freescale Semiconductor makes no warranty, representation or guarantee regarding the suitability of its products for any particular purpose, nor does Freescale Semiconductor assume any liability arising out of the application or use of any product or circuit, and specifically disclaims any and all liability, including without limitation consequential or incidental damages. "Typical" parameters that may be provided in Freescale Semiconductor data sheets and/or specifications can and do vary in different applications and actual performance may vary over time. All operating parameters, including "Typicals", must be validated for each customer application by customer's technical experts. Freescale Semiconductor does not convey any license under its patent rights nor the rights of others. Freescale Semiconductor products are not designed, intended, or authorized for use as components in systems intended for surgical implant into the body, or other applications intended to support or sustain life, or for any other application in which the failure of the Freescale Semiconductor product could create a situation where personal injury or death may occur. Should Buyer purchase or use Freescale Semiconductor products for any such unintended or unauthorized application, Buyer shall indemnify and hold Freescale Semiconductor and its officers, employees, subsidiaries, affiliates, and distributors harmless against all claims, costs, damages, and expenses, and reasonable attorney fees arising out of, directly or indirectly, any claim of personal injury or death associated with such unintended or unauthorized use, even if such claim alleges that Freescale Semiconductor was negligent regarding the design or manufacture of the part.

Freescale™ and the Freescale logo are trademarks of Freescale Semiconductor, Inc. All other product or service names are the property of their respective owners.

© Freescale Semiconductor, Inc. 2005. All rights reserved.