

AN14770

Using SmartDMA for Keyscan on MCX A Series MCU

Rev. 1.1 — 12 March 2026

Application note

Document information

Information	Content
Keywords	AN14770, Pmod header, SmartDMA, keyscan, MCX A
Abstract	This application note introduces the keyscan solution for MCX A series MCU.



1 Introduction

This application note introduces the keyscan solution for MCX A series MCU. It includes the introduction of the keyscan solution, its features and API routines, and a demo.

All MCX A series MCUs include a SmartDMA coprocessor, which can effectively reduce the load on the Arm core and perform fast I/O operations.

2 Target application

As the name suggests, the keyscan solution is used in key scanning applications, such as in a computer keyboard. However, it can also be used in other scenarios, such as in a requirement where continuous scanning of IO port input is required.

3 Keyscan interfaces

The keyscan scheme has no fixed interface. It can be used for matrix scanning and for row or column scanning. The number of scanned keys can be one or from one to two hundreds.

If it is a commonly used computer keyboard, it is generally 101 keys, 104 keys, or 87 keys. If it is a small keyboard, it is 4x4 to get 16 keys generally. It can also be used for irregular button matrix. In short, the button layout and the number of buttons can be customized.

This document uses a 4x4 matrix keyboard, however, the interface is not fully compatible. It only supports the determination of 2x4 with a total of 8 keys. To achieve the determination of 16 keys, rework the hardware with some wires.

4 Features of keyscan solution

The features of the keyscan solution are as follows:

- 4x4 keyscan
- Superfast key scan without Arm core intervention (≥ 8 kHz report rate)
- Programmable debounce time
- Easy to support 8x16 or other size
- Easily portable to other platforms

5 Functional description

This section describes the functional description of the keyscan solution.

5.1 Keyscan engine

SmartDMA, functioning as a coprocessor for the MCX A series MCU, is designed for highly efficient instruction execution. It can quickly and efficiently complete key scanning operations. During the scanning process of button operations, the Arm core need not intervene. An interrupt is sent to the Arm core only when there is a change in the key value. The Arm core must only read the key value from the RAM.

5.1.1 Keyscan driver lib

The instructions of SmartDMA use the type of machine code. The code implements the functions of the keyscan solution and is released in a C array. Some API routines are provided in this application. You can use API routines to initialize the engine and configure the pins, start, or stop keyscan.

5.2 System clock

The keyscan engine shares the system clock with the Arm core. Lowering the system clock frequency reduces the speed at which SmartDMA executes code.

5.3 Memory usage

The code of SmartDMA must be loaded and executed at a fixed location, which in this application is 0x04000000. Changing the execution instruction location requires regeneration of the instruction code array.

5.4 Hardware description

Connect the PmodKYPD board with the FRDM-MCXA346 board, as shown in [Figure 1](#).



Figure 1. Hardware connection

Note: The PmodKYPD board can be purchased from [here](#).

[Figure 2](#) shows the PmodKYPD schematic.

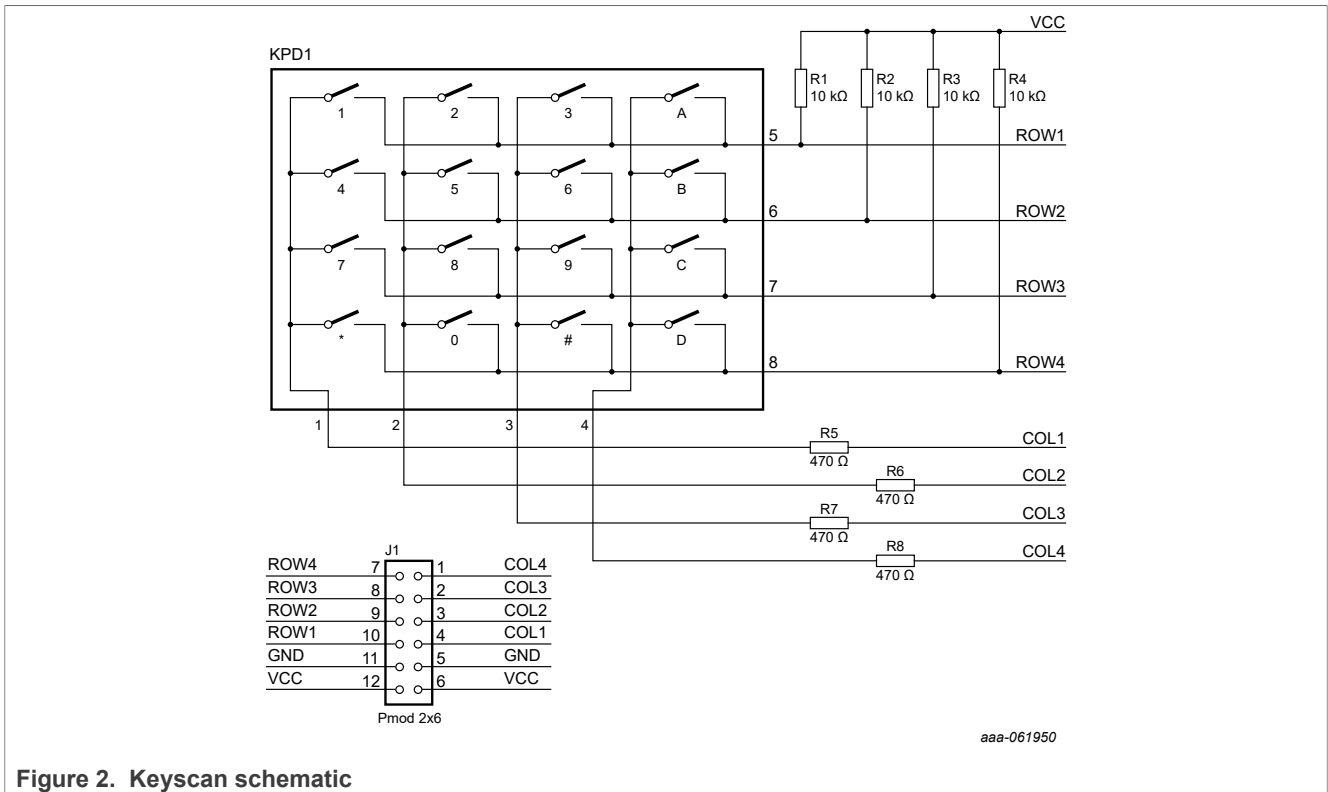

Figure 2. Keyscan schematic

Figure 3 shows the schematic of Pmod header on the FRDM-MCXA346 board.

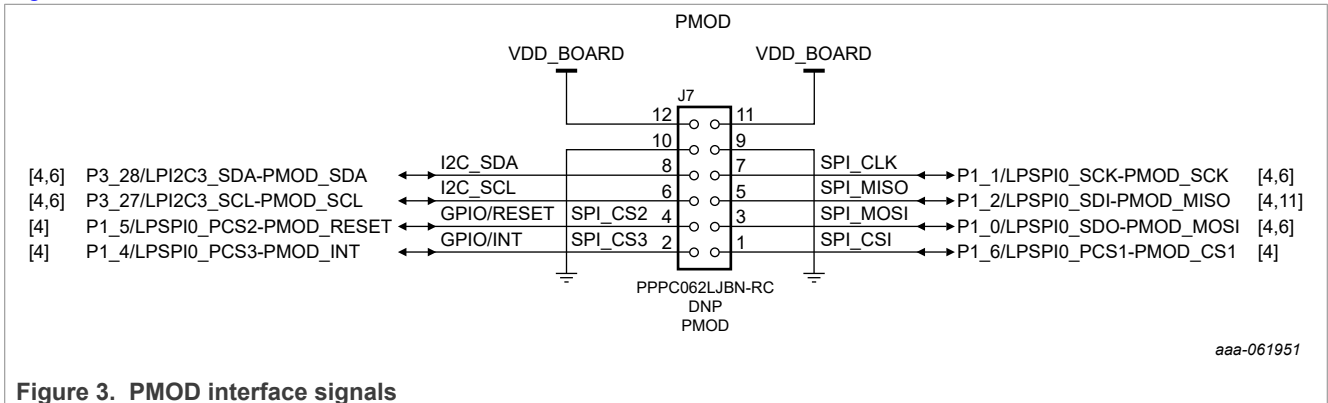

Figure 3. PMOD interface signals

5.4.1 Pin description

Figure 4 shows how to connect the PmodKYPD board with the FRDM-MCXA346 board.

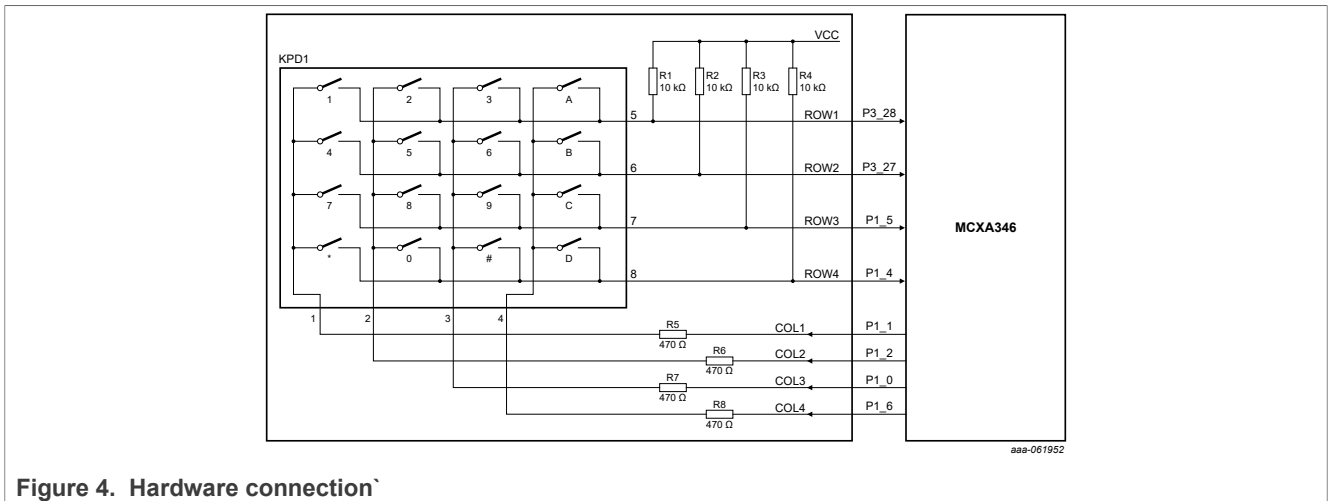

Figure 4. Hardware connection`

5.5 Keyscan timings

When a key is not pressed, the SmartDMA continuously outputs waveforms on each column line. However, when a key is pressed, the row where the key is located has the same waveform as the column where it is located. In this way, it can locate which button is pressed.

6 Software description

This section describes the SmartDMA keyscan example and the functions to implement it.

6.1 Demo example introduction

The config tool generates the demo code in this example as a standalone "Hello World" project. Based on this project, I/O initialization code and SmartDMA driver code are added.

6.2 SmartDMA function array

The SmartDMA keyscan API can be found in the file `fsl_smartdma_mcxn.h`:

```

/*!
 * @brief The API index when using s_smartdmaKeyscanFirmware
 */
enum _smartdma_keyscan_api
{
    /*!using Smartdma to control GPIO . */
    kSMARTDMA_Keyscan_4x4 = 0U,
};
    
```

In the `fsl_smartdma_mcxn.c` file, there is an array called `s_smartdmaKeyscanFirmware`, which contains the implementation of SmartDMA keyscan functions. The purpose of encapsulating the SmartDMA functions into an array is to reduce the research cost for users. This approach allows them to use pre-implemented module functions directly, enabling faster development of application features.

6.3 SmartDMA initialization

[Table 1](#) lists the functions that implement the SmartDMA initialization.

Table 1. API routines

Routine	Description
SMARTDMA_InitWithoutFirmware	Initialize the SmartDMA
SMARTDMA_InstallFirmware	Install the firmware
SMARTDMA_InstallCallback	Install the complete callback function
SMARTDMA_Boot	To run the program, boot the SmartDMA
SMARTDMA_Deinit	Deinitialize the SmartDMA
SMARTDMA_Reset	Reset the SmartDMA
SMARTDMA_HandleIRQ	SmartDMA IRQ
SmartDMA_keyscan_callback	SmartDMA interrupt callback

6.3.1 Init SmartDMA

To enable SmartDMA, perform the following operations:

- Clear reset of SmartDMA
- Enable the clock for SmartDMA
- Enable the IRQ for SmartDMA

6.3.2 Install SmartDMA firmware

The function module of SmartDMA must be placed at a fixed memory address to work properly. In this application, it must be placed at 0x04000000.

For example:

```

/*! @brief The firmware used for keyscan. */
extern const uint8_t s_smartdmaKeyscanFirmware[];
/*! @brief The s_smartdmaKeyscanFirmware firmware memory address. */
#define SMARTDMA_KEYSCAN_MEM_ADDR 0x04000000U
/*! @brief Size of s_smartdmacameraFirmware */
#define SMARTDMA_KEYSCAN_FIRMWARE_SIZE (s_smartdmaKeyscanFirmwareSize)
/*! @brief Size of s_smartdmacameraFirmware */
extern const uint32_t s_smartdmaKeyscanFirmwareSize;

```

The process of installing SmartDMA firmware is essentially copying the code array of SmartDMA function modules to a specified RAM address.

The following snippet is the related code:

```
SMARTDMA_InitWithoutFirmware();  
SMARTDMA_InstallFirmware(SMARTDMA_KEYSCAN_MEM_ADDR, s_smartdmaKeyscanFirmware,  
SMARTDMA_KEYSCAN_FIRMWARE_SIZE);
```

6.3.3 SmartDMA callback routine

SmartDMA can actively trigger an interruption in the Arm core, such as after the end of data transfer.

SmartDMA has a related interrupt number (SMARTDMA_IRQHandler) in the Arm vector table. In the configuration phase of SmartDMA, a callback function can be installed.

The following snippet is the related code:

```
SMARTDMA_InstallCallback(SmartDMA_keyscan_callback, NULL);
```

In the callback function, the Arm core can read the pressed key value and print the log.

6.3.4 Boot SmartDMA API

In the application, define a structure to set parameters related to SmartDMA. These parameters include the address of the data buffer, the length of data transfer, and the address of SmartDMA stack space. The most important thing is to find an API that must be executed from the SmartDMA function block code.

The following snippet is the related code:

```
smartdmaParam.smartdma_stack = (uint32_t*)g_samrtdma_stack;  
smartdmaParam.p_gpio_reg = (uint32_t*)g_keyscan_gpio_register;  
smartdmaParam.p_keyvalue = (uint32_t*)KeyValue; smartdmaParam.p_keycan_interval  
= (uint32_t*)&g_keyscan_interval; SMARTDMA_Boot(kSMARTDMA_Keyscan_4x4,  
&smartdmaParam, 0x2);
```

The boot process involves assigning the address of the corresponding API to the program counter of SmartDMA after which it begins to execute the function block.

7 Download and run demo based on FRDM-MCXA346

This section describes how to prepare and run the demo that is based on the FRDM-MCXA346 board. The demo can be found in the software package SDK_25_06_00_FRDM-MCXA346.

The example path: <SDK installation directory>\boards\frdm-mcxa346\component_examples\smartdma_keyscan

7.1 Prepare the demo

To prepare the demo, perform the following steps:

1. Connect the USB Type-C to micro-USB cable between the PC host and the USB port on the board.
2. Open a serial terminal on a PC for the serial device with the following settings:
 - Baud rate = 115200
 - Data bits = 8
 - Parity = None
 - Stop bit = One
 - Flow control = None

3. Download the program to the target board.

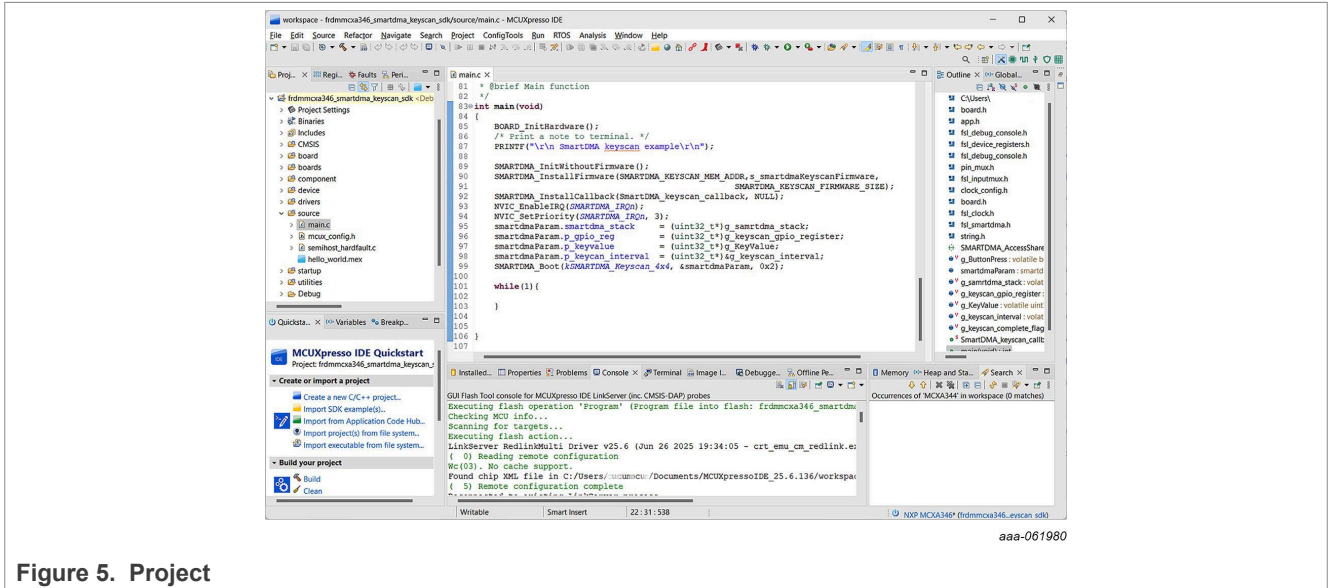

Figure 5. Project

4. To begin running the demo, either press the reset button on your board or launch the debugger in your IDE.

7.2 Run the demo

To run the demo, perform the following steps:

1. When the demo program is executed, the serial terminal prints the following lines:

```
SmartDMA keyscan example
```

2. Press any button on PmodKYPD. As a result, the serial terminal prints the following lines:

```
Button 2 is pressed
Button 1 is pressed
Button B is pressed
Button 6 is pressed
Button 5 is pressed
```

8 Note about the source code in the document

Example code shown in this document has the following copyright and BSD-3-Clause license:

Copyright 2026 NXP Redistribution and use in source and binary forms, with or without modification, are permitted provided that the following conditions are met:

1. Redistributions of source code must retain the above copyright notice, this list of conditions and the following disclaimer.
2. Redistributions in binary form must reproduce the above copyright notice, this list of conditions and the following disclaimer in the documentation and/or other materials must be provided with the distribution.
3. Neither the name of the copyright holder nor the names of its contributors may be used to endorse or promote products derived from this software without specific prior written permission.

THIS SOFTWARE IS PROVIDED BY THE COPYRIGHT HOLDERS AND CONTRIBUTORS "AS IS" AND ANY EXPRESS OR IMPLIED WARRANTIES, INCLUDING, BUT NOT LIMITED TO, THE IMPLIED WARRANTIES OF MERCHANTABILITY AND FITNESS FOR A PARTICULAR PURPOSE ARE DISCLAIMED. IN NO EVENT SHALL THE COPYRIGHT HOLDER OR CONTRIBUTORS BE LIABLE FOR ANY DIRECT, INDIRECT,

INCIDENTAL, SPECIAL, EXEMPLARY, OR CONSEQUENTIAL DAMAGES (INCLUDING, BUT NOT LIMITED TO, PROCUREMENT OF SUBSTITUTE GOODS OR SERVICES; LOSS OF USE, DATA, OR PROFITS; OR BUSINESS INTERRUPTION) HOWEVER CAUSED AND ON ANY THEORY OF LIABILITY, WHETHER IN CONTRACT, STRICT LIABILITY, OR TORT (INCLUDING NEGLIGENCE OR OTHERWISE) ARISING IN ANY WAY OUT OF THE USE OF THIS SOFTWARE, EVEN IF ADVISED OF THE POSSIBILITY OF SUCH DAMAGE.

9 Revision history

[Table 2](#) summarizes the revisions to this document.

Table 2. Revision history

Document ID	Release date	Description
AN14770 v.1.1	12 March 2026	Updated Section 7
AN14770 v.1.0	30 July 2025	Initial public release

Legal information

Definitions

Draft — A draft status on a document indicates that the content is still under internal review and subject to formal approval, which may result in modifications or additions. NXP Semiconductors does not give any representations or warranties as to the accuracy or completeness of information included in a draft version of a document and shall have no liability for the consequences of use of such information.

Disclaimers

Limited warranty and liability — Information in this document is believed to be accurate and reliable. However, NXP Semiconductors does not give any representations or warranties, expressed or implied, as to the accuracy or completeness of such information and shall have no liability for the consequences of use of such information. NXP Semiconductors takes no responsibility for the content in this document if provided by an information source outside of NXP Semiconductors.

In no event shall NXP Semiconductors be liable for any indirect, incidental, punitive, special or consequential damages (including - without limitation - lost profits, lost savings, business interruption, costs related to the removal or replacement of any products or rework charges) whether or not such damages are based on tort (including negligence), warranty, breach of contract or any other legal theory.

Notwithstanding any damages that customer might incur for any reason whatsoever, NXP Semiconductors' aggregate and cumulative liability towards customer for the products described herein shall be limited in accordance with the Terms and conditions of commercial sale of NXP Semiconductors.

Right to make changes — NXP Semiconductors reserves the right to make changes to information published in this document, including without limitation specifications and product descriptions, at any time and without notice. This document supersedes and replaces all information supplied prior to the publication hereof.

Suitability for use — NXP Semiconductors products are not designed, authorized or warranted to be suitable for use in life support, life-critical or safety-critical systems or equipment, nor in applications where failure or malfunction of an NXP Semiconductors product can reasonably be expected to result in personal injury, death or severe property or environmental damage. NXP Semiconductors and its suppliers accept no liability for inclusion and/or use of NXP Semiconductors products in such equipment or applications and therefore such inclusion and/or use is at the customer's own risk.

Applications — Applications that are described herein for any of these products are for illustrative purposes only. NXP Semiconductors makes no representation or warranty that such applications will be suitable for the specified use without further testing or modification.

Customers are responsible for the design and operation of their applications and products using NXP Semiconductors products, and NXP Semiconductors accepts no liability for any assistance with applications or customer product design. It is customer's sole responsibility to determine whether the NXP Semiconductors product is suitable and fit for the customer's applications and products planned, as well as for the planned application and use of customer's third party customer(s). Customers should provide appropriate design and operating safeguards to minimize the risks associated with their applications and products.

NXP Semiconductors does not accept any liability related to any default, damage, costs or problem which is based on any weakness or default in the customer's applications or products, or the application or use by customer's third party customer(s). Customer is responsible for doing all necessary testing for the customer's applications and products using NXP Semiconductors products in order to avoid a default of the applications and the products or of the application or use by customer's third party customer(s). NXP does not accept any liability in this respect.

Terms and conditions of commercial sale — NXP Semiconductors products are sold subject to the general terms and conditions of commercial sale, as published at <https://www.nxp.com/profile/terms>, unless otherwise agreed in a valid written individual agreement. In case an individual agreement is concluded only the terms and conditions of the respective agreement shall apply. NXP Semiconductors hereby expressly objects to applying the customer's general terms and conditions with regard to the purchase of NXP Semiconductors products by customer.

Export control — This document as well as the item(s) described herein may be subject to export control regulations. Export might require a prior authorization from competent authorities.

Suitability for use in non-automotive qualified products — Unless this document expressly states that this specific NXP Semiconductors product is automotive qualified, the product is not suitable for automotive use. It is neither qualified nor tested in accordance with automotive testing or application requirements. NXP Semiconductors accepts no liability for inclusion and/or use of non-automotive qualified products in automotive equipment or applications.

In the event that customer uses the product for design-in and use in automotive applications to automotive specifications and standards, customer (a) shall use the product without NXP Semiconductors' warranty of the product for such automotive applications, use and specifications, and (b) whenever customer uses the product for automotive applications beyond NXP Semiconductors' specifications such use shall be solely at customer's own risk, and (c) customer fully indemnifies NXP Semiconductors for any liability, damages or failed product claims resulting from customer design and use of the product for automotive applications beyond NXP Semiconductors' standard warranty and NXP Semiconductors' product specifications.

HTML publications — An HTML version, if available, of this document is provided as a courtesy. Definitive information is contained in the applicable document in PDF format. If there is a discrepancy between the HTML document and the PDF document, the PDF document has priority.

Translations — A non-English (translated) version of a document, including the legal information in that document, is for reference only. The English version shall prevail in case of any discrepancy between the translated and English versions.

Security — Customer understands that all NXP products may be subject to unidentified vulnerabilities or may support established security standards or specifications with known limitations. Customer is responsible for the design and operation of its applications and products throughout their lifecycles to reduce the effect of these vulnerabilities on customer's applications and products. Customer's responsibility also extends to other open and/or proprietary technologies supported by NXP products for use in customer's applications. NXP accepts no liability for any vulnerability. Customer should regularly check security updates from NXP and follow up appropriately. Customer shall select products with security features that best meet rules, regulations, and standards of the intended application and make the ultimate design decisions regarding its products and is solely responsible for compliance with all legal, regulatory, and security related requirements concerning its products, regardless of any information or support that may be provided by NXP.

NXP has a Product Security Incident Response Team (PSIRT) (reachable at PSIRT@nxp.com) that manages the investigation, reporting, and solution release to security vulnerabilities of NXP products.

NXP B.V. — NXP B.V. is not an operating company and it does not distribute or sell products.

Trademarks

Notice: All referenced brands, product names, service names, and trademarks are the property of their respective owners.

NXP — wordmark and logo are trademarks of NXP B.V.

AMBA, Arm, Arm7, Arm7TDMI, Arm9, Arm11, Artisan, big.LITTLE, Cordio, CoreLink, CoreSight, Cortex, DesignStart, DynamIQ, Jazelle, Keil, Mali, Mbed, Mbed Enabled, NEON, POP, RealView, SecurCore, Socrates, Thumb, TrustZone, ULINK, ULINK2, ULINK-ME, ULINK-PLUS, ULINKpro, μ Vision, Versatile — are trademarks and/or registered trademarks of Arm Limited (or its subsidiaries or affiliates) in the US and/or elsewhere. The related technology may be protected by any or all of patents, copyrights, designs and trade secrets. All rights reserved.

Microsoft, Azure, and ThreadX — are trademarks of the Microsoft group of companies.

Contents

1	Introduction	2
2	Target application	2
3	Keyscan interfaces	2
4	Features of keyscan solution	2
5	Functional description	2
5.1	Keyscan engine	2
5.1.1	Keyscan driver lib	3
5.2	System clock	3
5.3	Memory usage	3
5.4	Hardware description	3
5.4.1	Pin description	4
5.5	Keyscan timings	5
6	Software description	5
6.1	Demo example introduction	5
6.2	SmartDMA function array	5
6.3	SmartDMA initialization	6
6.3.1	Init SmartDMA	6
6.3.2	Install SmartDMA firmware	6
6.3.3	SmartDMA callback routine	7
6.3.4	Boot SmartDMA API	7
7	Download and run demo based on FRDM-MCXA346	7
7.1	Prepare the demo	7
7.2	Run the demo	8
8	Note about the source code in the document	8
9	Revision history	9
	Legal information	10

Please be aware that important notices concerning this document and the product(s) described herein, have been included in section 'Legal information'.
