

AN1556

Designing Sensor Performance Specifications for MCU-based Systems

Prepared by: Eric Jacobsen and Jeff Baum
Sensor Systems Engineering Group
Motorola Sensor Products Division
Phoenix, AZ

INTRODUCTION

When designing a circuit for a sensor system, it is desirable to use fixed-value components in the design. This makes the system easier and cheaper to produce in high volume. The alternatives to using fixed-value circuitry are very expensive and usually impractical: laser-trimming resistances, manually calibrating potentiometers, or measuring and selecting specific component values are all very labor-intensive processes. However, every sensor has device-to-device variations in offset output voltage, full-scale output voltage, dynamic output voltage range (difference between the full-scale output voltage and zero-scale output voltage which is commonly referred to as the span), etc. Moreover, these same parameters also vary with temperature — e.g., temperature coefficient of offset (TCV_{off}) and temperature coefficient of full-scale span (TCV_{FSS}). To further complicate this situation, the fixed-value circuit in which a sensor is applied also has variation — e.g., the voltage or current regulator and resistors all have a specified tolerance.

Since today's unamplified solid-state sensors typically have an output voltage on the order of tens of millivolts (Motorola's basic 10 kPa pressure sensor, MPX10, has a typical full-scale span of 58 mV, when powered with a 5 V supply), a major part of the fixed-value circuitry is a gain stage that amplifies the signal to a level that is large enough for additional processing. Typically, this additional processing is digitization of the amplified analog sensor signal by a microcontroller's A/D converter. To obtain the best signal resolution with an A/D, the sensor's amplified dynamic output voltage range should fill as much of the A/D window (difference between the A/D's high and low reference voltages) as possible without extending beyond the high and low reference voltages (i.e., the zero-pressure offset voltage must be greater than or equal to the low reference voltage, and the full-scale output voltage must be less than or equal to the high reference voltage). In any case, the device-to-device, temperature, and circuit variations create a design dilemma: with a fixed-value amplifier circuit, the gain as well as any dc level shift incorporated in the amplifier design are fixed. If the variation of any of the aforementioned sensor parameters is too large, the amplified sensor output may saturate the amplifier near either its high or low supply rail or may extend beyond either the high or low reference voltages of the A/D converter. In either case, error (non-linearity) results in the

system. To avoid this scenario, the solution is to design a fixed-value circuit that optimizes performance (signal resolution) while taking into account all possible types of variation that may cause the sensor output to vary. In other words, the goal of this fixed-value sensor system is to attain the best performance possible while ensuring through design, regardless of any system variation, that the sensor's amplified output will ALWAYS be within the saturation levels of the amplifier and the high and low reference voltages of an A/D converter.

The implication of ensuring that the sensor's amplified output is always unsaturated and within the high and low reference voltages of the A/D is that an accurate software calibration of the sensor's output is possible. By sampling the sensor's output voltage at a couple of points at room temperature (zero and full-scale output, for example), all the room temperature device-to-device and circuit variations are nullified. Obviously, temperature variations will create error in the system (sensor's output voltage will drift with changing temperature), but, by design, the sensor's output voltage will remain within the A/D's valid range.

This paper discusses a methodology that optimizes a sensor system's performance while considering device-to-device, temperature, and circuit variations that can create variation in the amplified sensor output. The methodology starts with a desired performance and some established parameters and then considers each type of variation in a worst case analysis to determine if the desired performance is attainable. While this paper discusses this methodology for pressure sensors and a specific amplifier topology, the methodology is applicable to low-level, differential-voltage output sensors and amplifier circuits in general. Two specific examples are presented that apply this methodology. The first example uses Motorola's MPX10 pressure sensor, and the second example uses Motorola's MPX2010 pressure sensor. Both sensors have a full-scale rated pressure of 10 kPa; the difference between the devices is the MPX2010 has on-chip calibration and temperature compensation circuitry to calibrate and temperature compensate the zero-pressure offset voltage and span. The comparison of these two devices will emphasize how dramatically device-to-device and temperature variations, if not compensated, can affect a system's overall performance.



THE EXAMPLE CIRCUIT

Referring to Figure 1, both pressure sensors are interfaced to the same amplifier circuit topology. In Tables 1 and 2, the relevant characteristics for the MPX10 and MPX2010 show the device-to-device and temperature variations. Additionally, the tolerances on the voltage regulator and the

resistors that establish the gain and dc voltage level shift (V_{REF}) are considered in the methodology. The voltage regulator's device-to-device tolerance is $\pm 5\%$, and each resistor's tolerance is $\pm 1\%$.

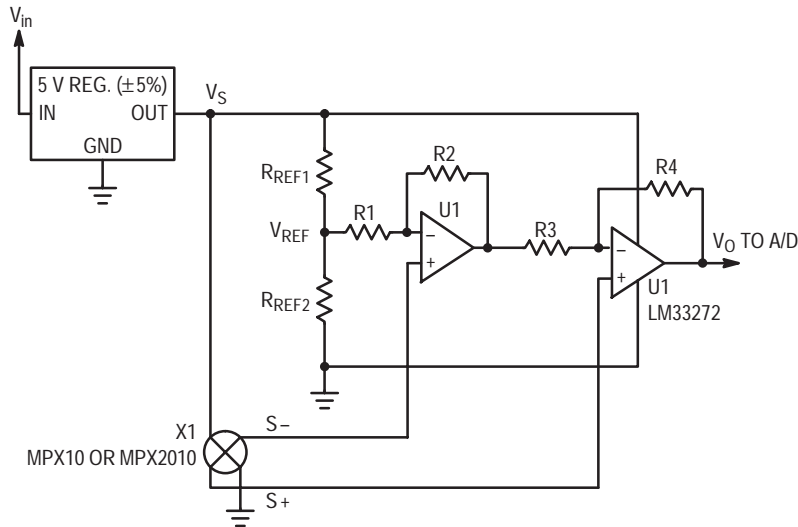

Figure 1. MPX10/MPX2010 Circuit Schematic

Table 1. MPX10 Variation Characteristics

Characteristic ($V_S = 5.0\text{ V}$)	Symbol	Min	Typ	Max	Unit
Pressure Range	P_{OP}	0	—	10	kPa
Full-Scale Span	V_{FSS}	33	58	83	mV
Zero Pressure Offset	V_{off}	0	33	58	mV
Temperature Coefficient of Full-Scale Span (see Note 1)	TCV_{FSS}	-0.22	-0.19	-0.16	$\%/^{\circ}\text{C}$
Temperature Coefficient of Offset (see Note 2)	TCV_{off}	—	± 15	—	$\mu\text{V}/^{\circ}\text{C}$

Note 1: Slope of end-point straight line fit to full-scale span at -40°C and $+125^{\circ}\text{C}$ relative to 25°C

Note 2: Slope of end-point straight line fit to zero pressure offset at -40°C and $+125^{\circ}\text{C}$ relative to 25°C

Table 2. MPX2010 Variation Characteristics

Characteristic ($V_S = 5.0\text{ V}$)	Symbol	Min	Typ	Max	Unit
Pressure Range	P_{OP}	0	—	10	kPa
Full-Scale Span	V_{FSS}	12	12.5	13	mV
Zero Pressure Offset	V_{off}	-0.5	—	0.5	mV
Temperature Effect on Full-Scale Span (see Note 1)	TCV_{FSS}	-1.0	—	1.0	$\%FSS$
Temperature Effect on Offset (see Note 2)	TCV_{off}	-0.5	—	0.5	mV

Note 1: Maximum change in full-scale span at 0°C and 85°C relative to 25°C

Note 2: Maximum change in offset at 0°C and 85°C relative to 25°C

The amplifier topology used is a two-operational amplifier gain stage that has all the desirable characteristics of a differential-signal instrumentation amplifier:

- high input impedance
- low output impedance
- differential to single-ended conversion of the input signal
- high gain capability
- dc level shifting capability

For good common mode rejection, the following resistor ratios are used:

$$\frac{R_4}{R_3} = \frac{R_1}{R_2}$$

With this simplification, the transfer function of the amplifier is

$$V_O = \left(\frac{R_4}{R_3} + 1 \right) (S^+ - S^-) + V_{REF}$$

Where the gain is $\left(\frac{R_4}{R_3} + 1\right)$, the pressure sensor's differential output voltage is the quantity $(S^+ - S^-)$, and the positive dc voltage level shift, created by the voltage divider comprised of R_{REF1} and R_{REF2} , is V_{REF} . In addition to using the above resistor ratios to preserve the common mode rejection, the effective resistance of the parallel combination of R_{REF1} and R_{REF2} should be a low impedance to ground relative to the resistance of R_1 .

RESOLUTION AND FACTORS THAT AFFECT IT

Performance of a pressure sensor system is directly related to its resolution. Resolution is the smallest increment of pressure that the system can resolve — e.g., a system that measures pressure up to 10 kPa (full-scale) with a resolution of 1% of full-scale can resolve pressure increments of 0.1 kPa. Similarly, the resolution (smallest increment of voltage) of an 8-bit A/D converter with a 5 V window (a high reference voltage of 5 V and a low reference voltage of 0 V) is

$$\frac{5 \text{ V}}{255 (8 \text{ bits})} = 19.6 \text{ mV}$$

Many pressure sensor systems interface an A/D converter. If the above system example requires 1% resolution when interfaced to an A/D, the pressure sensor signal's span must be at least

$$\frac{19.6 \text{ mV}}{1\%} = 1.96 \text{ V}$$

If the system resolution required is 0.5%, the pressure sensor signal's span must be at least

$$\frac{19.6 \text{ mV}}{0.5\%} = 3.92 \text{ V}$$

From these examples, the greater the resolution required, the greater the sensor's amplified span must be to meet the resolution requirement. Since a pressure sensor's span before amplification is only on the order of tens of millivolts, the amplifier must be designed to provide the minimum span that gives the desired resolution. If the amplifier has a fixed gain, any device-to-device variation in the sensor's unamplified span will result in variation of the amplified span. If, for example, the sensor's span variation results in an amplified span that is smaller than required, the resolution of the system will not be as high as desired. Alternately, if the sensor's span variation results in an amplified span that is larger than required, the resolution will be better than desired, BUT the amplified span may also either saturate the amplifier near its supply rails or extend outside the high and low reference voltages of the A/D. Voltages above the high reference will be digitally converted as 255 decimal (for 8-bit A/D), and voltages below the low reference will be converted as 0. This creates a non-linearity in the analog-to-digital conversion and in the overall system transfer function.

As presented above, the variation of the sensor's span creates a dilemma: how does one design a fixed-gain amplifier that gives the desired resolution, does not violate the

limits of the linear output ranges of the op-amps and A/D converter, and also accommodates the complete distribution of possible sensor spans? The same question is presented to the additional sources of variation: device-to-device variation in the zero-pressure offset voltage and temperature effects on both the sensor's span and zero-pressure offset voltage. Also any component tolerances for the voltage regulator and resistors must be considered.

Designing the system when only one source of variation is involved is not difficult; however, when all of these variations are interacting, the solution becomes complicated. The rest of this paper describes a design methodology that considers all of the above variations and their interactions. Worst case limits will be used in designing the fixed-value system.

RESOLUTION vs. HEADROOM

As stated previously, the amplified span of the sensor must "fit" within the high and low references of an A/D to avoid any nonlinearity errors. And the span must also be large enough to provide the resolution required for the application. Any part of the A/D's "window" that is not used for the sensor's dynamic signal range is called headroom. Headroom may be thought of as a cushion between the high and low reference voltages and the sensor's dynamic output range. This "cushion" is used to allow the sensor's dynamic range to move and/or vary within the A/D's window. A general description is shown in Figure 2. The total amount of sensor output signal variation (due to temperature effects, device-to-device variation, and interface circuit component tolerances) cannot exceed the headroom that is available for the requisite amount of system resolution. A larger sensor span (more bits used for signal resolution) means a smaller amount of headroom available to accommodate sensor parameter and interface circuit variations. This makes the tradeoff between resolution and variation obvious. The more variation in the system, the more headroom that is required to allow for the variation and, consequently, less of the A/D window is available for the sensor's "true-signal" span. Less span results in poorer resolution (less bits used for resolving sensor output signal).

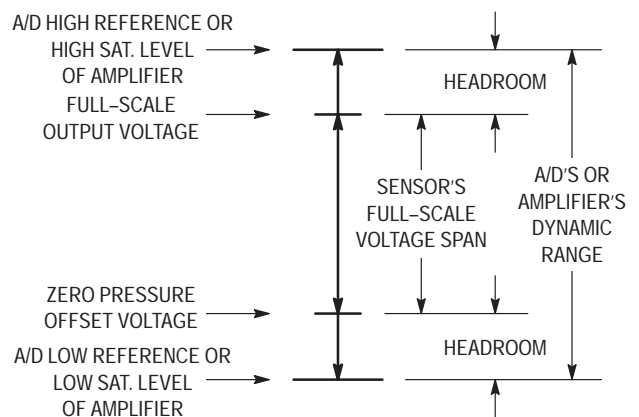

Figure 2. Sensor's Full-Scale Span vs. Headroom

THE METHODOLOGY TO OPTIMIZE PERFORMANCE

The methodology starts with defining all the known parameters. The parameters with an asterisk (*) are specified at 25°C.

- **Resolution** = Desired system resolution
- **MaxFSS (*)** = Maximum full-scale voltage span of the pressure sensor
- **MinFSS (*)** = Minimum full-scale voltage span of the pressure sensor
- **TCV_{FSS} (*)** = The maximum temperature coefficient of the sensor's full-scale voltage span
- **MaxSensOff (*)** = The maximum zero pressure offset voltage of the pressure sensor
- **MinSensOff (*)** = The minimum zero pressure offset voltage of the pressure sensor
- **TCV_{off}** = The sensor's maximum temperature coefficient of offset voltage
- **V_{lo}** = The low saturation level of the amplifier or low reference voltage of an A/D (whichever is most limiting case)
- **V_{hi}** = The high saturation level of the amplifier or the high reference voltage of an A/D (whichever is most limiting case)
- **V_{REF}** = The reference voltage for positive dc voltage level shifting
- **V_{tol}** = The voltage regulator tolerance
- **MinTemp** = The application's minimum operating temperature
- **Maxtemp** = The application's maximum operating temperature

These parameters are either chosen for the application (e.g., system resolution) or can be determined from the sensor's data sheet. Tables 1 and 2 provide the necessary information for the design examples presented here.

Note: The data in Tables 1 and 2 are scaled for a 5 V supply voltage, whereas the MPX10 and MPX2010 data sheets are specified at a 3 V and 10 V supply voltage, respectively.

The following steps outline the methodology that will be applied to the MPX10 in the first design example and then applied to the MPX2010 in the second design example.

1. Determine/choose the required Resolution for the system.
2. Calculate the number of steps required for the chosen resolution. The resolution determines the number of steps into which the pressure signal needs to be broken [see Figure 3 where an 8-bit A/D (255 steps of resolution) is assumed]. A conservative approach to determining this number of steps is to assume that with an A/D, the digital quantization of the pressure signal can be plus or minus one step. Therefore, assume that it takes twice the number of steps previously determined to resolve a given minimum incremental pressure. The number of steps for the chosen resolution is

$$\text{Number of Steps} = \frac{2 \cdot 100}{\text{Resolution}}$$

The scaling factor of 100 in the numerator converts the resolution from a percentage to a decimal fraction.

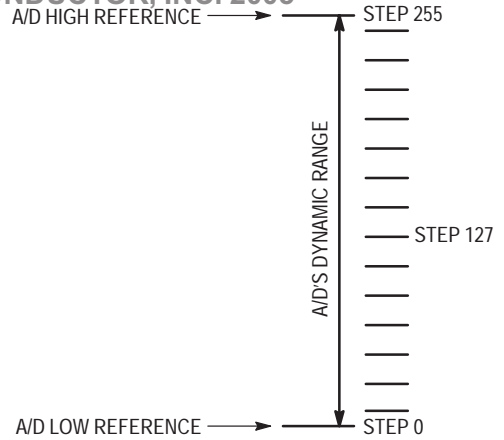

Figure 3. The 255 Digital Steps of an 8-Bit A/D

3. Calculate the minimum amplified sensor span (defined as the Minimum Required Span — see Figure 4) required for this resolution requirement. Using an 8-bit A/D with a 5 V window where one step equals 19.6 mV (for the nominal regulator voltage), the minimum amplified sensor span is

$$\text{Minimum Required Span} = (\text{Number of Steps}) \cdot (19.6 \text{ mV})$$

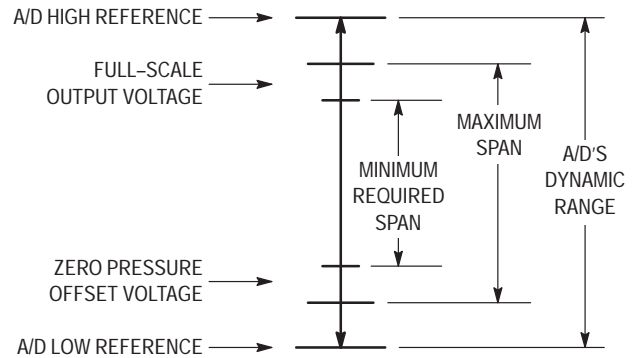

Figure 4. The Minimum Required Span for the Required Resolution and the Maximum Span Due to Sensor Span Variations

4. Calculate the amplifier's gain. The gain must be large enough to achieve, over the entire distribution of sensor spans, the Minimum Required Span. Therefore, this gain is calculated using the smallest pressure sensor voltage span, MinFSS. By using the worst case smallest pressure sensor voltage span to calculate the gain, the Minimum Required Span (the minimum span that will achieve the resolution requirement) is guaranteed for the entire distribution of sensor spans. The worst case minimum full-scale sensor span will occur at the hottest temperature, Maxtemp, in the application (not exceeding the operating temperature of the sensor), since the span decreases with increasing temperature (TCV_{FSS} is negative).

$$\text{Gain} = \frac{\text{Minimum Required Span}}{[\text{MinFSS}] \cdot [1 + \text{TCV}_{\text{FSS}} \cdot (\text{Maxtemp} - 25)]}$$

The term $[1 + \text{TCV}_{\text{FSS}} \cdot (\text{Maxtemp} - 25)]$ is the temperature effect on the span.

Summarizing (through Step 4), the calculations are based on a minimum desired resolution. The resolution requirement determines the number of steps or “pieces” into which the signal must be broken. This number of steps or “pieces” multiplied by the number of millivolts per step equals a minimum voltage range which is defined as the Minimum Required Span. Finally to ensure that this Minimum Required Span is achieved over the entire distribution of sensor spans, the gain is calculated using the worst case smallest sensor span.

Note: The gain also will have variation due to resistor tolerances in the amplifier circuit. To ensure that the system variation due to resistor tolerances is negligible when compared to other sources of variation, the system should be designed using resistors with tolerances of 1% or better.

- Calculate the worst case Maximum Span. The Maximum Span is the largest possible span and is calculated using the maximum full-scale sensor voltage span, MaxFSS, and the Gain. The worst case maximum full-scale sensor span occurs at the coldest temperature, MinTemp. After calculating the Maximum Span, the remaining dynamic range within the A/D’s window or saturation levels of the amplifier is the smallest number of “bits” (most limiting case) available for headroom.

$$\text{Maximum Span} =$$

$$[\text{Gain}] \cdot [\text{MaxFSS}] \cdot [1 + \text{TCV}_{\text{FSS}} \cdot (\text{MinTemp} - 25)]$$

The term $[1 + \text{TCV}_{\text{FSS}} \cdot (\text{MinTemp} - 25)]$ is the temperature effect on the span.

The Maximum Span calculated from the above equation is depicted in Figure 4.

- Calculate the Calculated Headroom. The Calculated Headroom is a subset of the general term “headroom” because it reserves “bits” in the A/D’s dynamic range only for the sources of variation from the sensor’s zero-pressure offset voltage. Headroom, in general, is reserved for all sources of variation: system components, resistor tolerances (if significant), and the sensor. However, the largest part of the “headroom” must be reserved for the device-to-device variations and temperature effects on the sensor’s zero-pressure offset voltage. Therefore, the sources of variation from the other system components are subtracted immediately from the headroom so that the focus can be on the sensor-related variations (refer to Figure 5 and the following equation for the Calculated Headroom). For these design examples, the supply is a single, regulated $5 \text{ V} \pm 5\%$ supply (the regulator’s tolerance is referred to as V_{tol}). An assumption for a typical rail-to-rail op-amp’s saturation levels (referred to as V_{lo} and V_{hi}) is 0.2 V above the low supply rail (ground) and 0.2 V below the high supply rail (5 V). Additionally, the worst case (smallest) supply voltage is $5 \text{ V} - 5\%$ or 4.75 V.

$$\text{Calculated Headroom} = 5 \cdot \left(1 - \frac{V_{\text{tol}}}{100}\right) - 2$$

$$\cdot V_{\text{lo}} - \text{Maximum Span}$$

The preceding equation assumes that the difference between V_{hi} and the high supply rail (or high reference of an A/D) is equal to the difference between V_{lo} and the low supply rail (or low reference of an A/D); thus the term $(2 \cdot V_{\text{lo}})$.

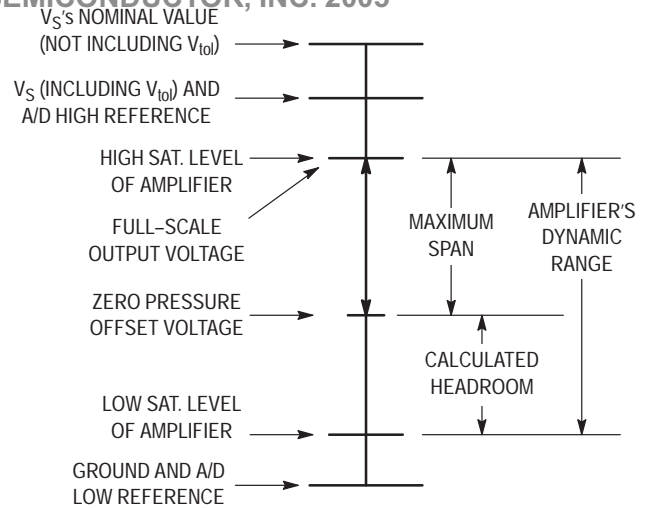

Figure 5. From Ground to V_S , a Section of Voltage Is Reserved for Each Source of Variation

Step 6 is considered a pivotal step because it transitions the methodology’s calculations from the performance requirements to the headroom requirements. Up to Step 6, the methodology considered only the span of the sensor to guarantee a minimum resolution despite device-to-device variation, component tolerances, and temperature effects. Upon calculating the Calculated Headroom, the remaining steps of the methodology that are detailed below consider the offset variations (due to device-to-device and temperature). These offset variations are added together to comprise what is defined as the Required Headroom which is the required number of “bits” in the A/D’s dynamic range needed to accommodate the offset variations. This Required Headroom is then compared to the Calculated Headroom (from the preceding calculation) to determine if the Calculated Headroom is sufficient to allow for the offset variations (i.e., the Calculated Headroom must be greater than or equal to the Required Headroom). In the case that the Calculated Headroom is not sufficiently large, relaxing the resolution requirement or reducing, if possible, the variation of either offset, span, component tolerances, or a combination of all three is required.

- Calculate the maximum offset drift due to temperature fluctuations (defined as the Maximum Temperature Effect on Offset). A conservative approach to this calculation is to determine the maximum total voltage change of offset over the application’s entire operating temperature range. This maximum change of offset is the product of the Gain, TCV_{off} , and the application’s entire operating temperature range (from Maxtemp to MinTemp). Since the temperature coefficient of offset can be positive or negative, the offset may increase or decrease with increasing temperature and, likewise, for decreasing temperature. Though this step only considers the maximum magnitude of the change in offset due to temperature, a segment in the Required Headroom is reserved for both possibilities of a positive or negative temperature coefficient of offset (see Figure 6). The sign (positive or negative) of the total offset change due to temperature is also considered in upcoming steps.

Maximum Temperature Effect on Offset = (Gain) • (TCV_{off}) • (Maxtemp – MinTemp)

Maximum Offset = [Gain] • [MaxSensOff] + Maximum Temperature Effect on Offset

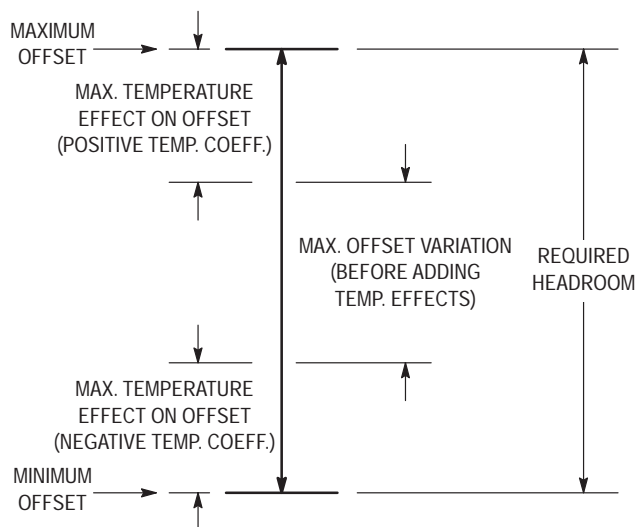
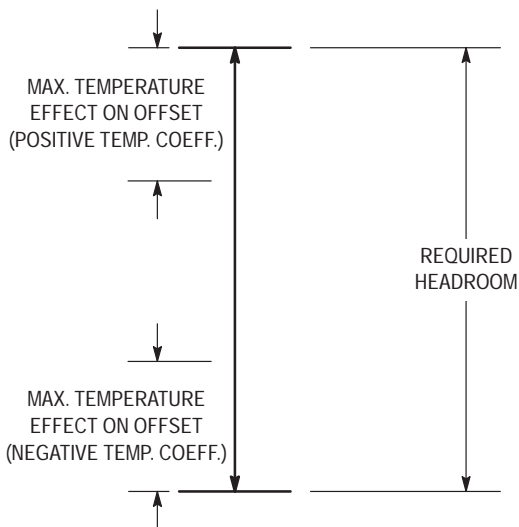

Figure 6. The Maximum Temperature Effect on Offset

Figure 7. Calculating the Maximum and Minimum Offsets

- Calculate the Maximum Offset Variation. The Maximum Offset Variation is the total amount of the Required Headroom that must be reserved to account for the entire distribution of sensor offsets (at room temperature — refer to Figure 7).

Maximum Offset Variation = [Gain] • [MaxSensOff – MinSensOff]

where largest offset is

[Gain] • [MaxSensOff]

and the smallest offset is

[Gain] • [MinSensOff]

- Calculate the worst case Minimum Offset. The worst case Minimum Offset includes both temperature effects (from Step 7) and device-to-device variations (from Step 8) to determine the smallest possible offset over the entire distribution of sensor offsets and over the operating temperature range. This worst case Minimum Offset occurs when a sensor has a nominal room temperature offset of MinSensOff (smallest offset in the sensor offset distribution) and a negative temperature coefficient so that the offset decreases with increasing temperature. Refer to Figure 7.

Minimum Offset = [Gain] • [MinSensOff] – Maximum Temperature Effect on Offset

- Similar to Step 9, calculate the worst case Maximum Offset. The worst case Maximum Offset includes both temperature effects (from Step 7) and device-to-device variations (from Step 8) to determine the largest possible offset over the entire distribution of sensor offsets and over the operating temperature range. This worst case Maximum Offset occurs when a sensor has a nominal room temperature offset of MaxSensOff (largest offset in the sensor offset distribution) and a positive temperature coefficient so that the offset increases with increasing temperature. Refer to Figure 7.

- Calculate the Required Headroom. Referring to Figure 7, the Required Headroom is the difference between the Maximum Offset and Minimum Offset and is the amount of voltage range (bits of the A/D) required to allow for device-to-device and temperature variations of the sensor's offset.

Required Headroom = Maximum Offset – Minimum Offset

- Compare the Required Headroom of Step 11 to the Calculated Headroom of Step 6. The Calculated Headroom is the absolute maximum amount of offset variation (due to device-to-device variations and temperature effects) that the system can allow for the desired resolution. If the Required Headroom is greater than the Calculated Headroom, the desired resolution is not attainable for all worst case variations due to temperature effects, component tolerances, and device-to-device variations. Therefore, the requirement to attain the desired system resolution is:

Calculated Headroom ≥ Required Headroom

If this requirement is not met, as stated previously, the alternatives to meeting this requirement are the following:

- Relax the Resolution requirement and repeat the methodology.
- Reduce (tighten) the span or offset (or both) variation and repeat the methodology.
- Reduce temperature coefficients.
- Reduce the component tolerances and repeat the methodology.
- Repeat the methodology by performing a combination of the above suggestions.

Once the above headroom requirement is met, the final step is to determine the proper value of V_{REF} :

13. A dc offset, V_{REF} , is required to position the sensor's span within the A/D window so that no device-to-device or temperature variation nor component tolerances cause the sensor's output to be outside the A/D window. Therefore, calculate the V_{REF} required to ensure that the sensor's smallest zero-pressure offset voltage (Minimum Offset) is greater than or equal to V_{I0} (refer to Figures 5 and 7). In other words, the sum of the reference voltage and Minimum Offset must be greater than or equal to the amplifier's low saturation voltage:

$$V_{REF} + \text{Minimum Offset} \geq V_{I0}$$

Solving for V_{REF} :

$$V_{REF} \geq V_{I0} - \text{Minimum Offset}$$

Note: The reference voltage, V_{REF} , also will have variation due to resistor tolerances in the resistor divider used to create V_{REF} . To ensure that the system variation due to resistor tolerances is negligible when compared to other sources of variation, the system should be designed using resistors with tolerances of 1% or better.

The following design examples use the methodology.

DESIGN EXAMPLES WITH THE MPX10 AND MPX2010

The following table lists the methodology's steps. The table entries (names) will correspond to the names used in the methodology outlined above; additionally, the step number (Step 1, etc.) is bracketed ([]) and superscripted next to the entry to which the step refers. The first column lists the given parameters that should be available in or derived from the appropriate component's (sensor, amplifier, voltage regulator, resistors) data sheet. The second column lists the performance requirements of the sensor system (i.e., this column lists all the calculations that relate to ensuring a minimum sensor span to achieve the desired resolution despite device-to-device variations, temperature effects and component tolerances). The third column lists the calculations that determine the headroom for the system given component tolerances and the device-to-device variations and temperature effects on the sensor's offset. The table and associated system design equations may easily be implemented in a spreadsheet to efficiently perform the required calculations.

Table 3. Design Example Using the MPX10

Given Parameters	Performance Parameters	Headroom Parameters
MaxFSS (mV @ 25°C) 83	^[1] Resolution (% FSS) 4.5	^[7] Maximum Temperature Effect on Offset (V) 0.03
MinFSS (mV @ 25°C) 33	^[2] Number of Steps 44	^[8] Maximum Offset Variation (V) 1.76
TCV _{FSS} (% FSS/°C) -0.22	^[3] Minimum Required Span (V) 0.87	^[9] Minimum Offset (V) -0.03
MaxSensOff (mV @ 25°C) 58	^[4] Gain 29	^[10] Maximum Offset (V) 1.73
MinSensOff (mV @ 25°C) 0	^[5] Maximum Span (V) 2.57	^[13] V_{REF} (V) 0.23
TCV _{off} (μV/°C) ±15		
V_S (V) 5	^[6] Calculated Headroom (V) 1.78	^[11] Required Headroom (V) 1.75
V_{hi} (V) 4.8		
V_{I0} (V) 0.2		^[12] I_S Calculated Headroom ≥ Required Headroom ?
V_{tol} (%) 5		
Maxtemp (°C) 70		
MinTemp (°C) 0		

Table 4. Design Example Using the MPX2010

Given Parameters	Performance Parameters	Headroom Parameters
MaxFSS (mV @ 25°C) 13	^[1] Resolution (% FSS) 1.2	^[7] Maximum Temperature Effect on Offset (V) 0.14
MinFSS (mV @ 25°C) 12	^[2] Number of Steps 167	^[8] Maximum Offset Variation (V) 0.55
TCV _{FSS} (% FSS) ±1	^[3] Minimum Required Span (V) 3.27	^[9] Minimum Offset (V) -0.27
MaxSensOff (mV @ 25°C) 0.5	^[4] Gain 275	^[10] Maximum Offset (V) 0.27
MinSensOff (mV @ 25°C) -0.5	^[5] Maximum Span (V) 3.61	^[13] V _{REF} (V) 0.47
TCV _{off} (mV, 0°C to 85°C) ±0.5		
V _S (V) 5	^[6] Calculated Headroom (V) 0.74	^[11] Required Headroom (V) 0.55
V _{hi} (V) 4.8		
V _{lo} (V) 0.2		^[12] I _S Calculated Headroom ≥ Required Headroom ?
V _{tol} (%) 5		
Maxtemp (°C) 85		
MinTemp (°C) 0		

DESIGN EXAMPLE COMPARISON SUMMARY
CONCLUSION

The preceding examples show how sources of variation can affect the overall system resolution. The MPX2010 has on-chip temperature compensation and calibration circuitry to reduce device-to-device variations and temperature effects. Consequently, when designing the fixed-value amplifier circuitry, the resolution possible with the MPX2010 is almost four times greater than the same amplifier circuit using an MPX10. In both examples, both systems' performance (Resolution) are optimized to be the best possible, given the distribution of the sensor device parameters and the other component variations.

As stated previously if the methodology's calculations show that the sensor's signal will always be within the dynamic range of the amplifier (and high and low reference voltages of the A/D), a software calibration may then be implemented to nullify any room temperature device-to-device and component variations.

It should be noted, however, that this methodology does not consider how to obtain the best performance from a single sensor system. Rather, the focus of the methodology is to obtain the best possible system performance while considering the distribution of device parameters that result from manufacturing and other sources of variation. By considering the sources of variation, the system may then be mass-produced without individually calibrating the sensor system hardware. Obviously, if each sensor system is hand-calibrated, the performance will be better. However, the hand-calibration also requires additional cost and time when producing the sensor system.

To guarantee a specified performance when designing a fixed-value circuit for sensor systems, all significant sources of variation must be considered. By considering the sources of variation (device-to-device variations, temperature effects, and component tolerances), the system may be designed so that the specified performance (resolution) is achieved while still keeping the sensor's amplified dynamic range within the A/D window (or saturation levels of the amplifier). The specified performance may be achieved in all cases by applying the methodology described herein. By first calculating the Minimum Required Span to achieve the required resolution in all scenarios and then determining if the remaining dynamic range or headroom is large enough to accommodate the sources of variation, the methodology determines if the resolution requirement is feasible. If the sources of variation are too large, the resolution requirement may not be attainable. In such a case, the resolution requirement should be relaxed, or the sources of variation must be decreased. Finally, once the system is successfully designed to ensure that the sensor signal will always be within the dynamic range of the amplifier (and high and low reference voltages of the A/D), a software calibration may be implemented to nullify any room temperature device-to-device and component variations.

Motorola reserves the right to make changes without further notice to any products herein. Motorola makes no warranty, representation or guarantee regarding the suitability of its products for any particular purpose, nor does Motorola assume any liability arising out of the application or use of any product or circuit, and specifically disclaims any and all liability, including without limitation consequential or incidental damages. "Typical" parameters can and do vary in different applications. All operating parameters, including "Typicals" must be validated for each customer application by customer's technical experts. Motorola does not convey any license under its patent rights nor the rights of others. Motorola products are not designed, intended, or authorized for use as components in systems intended for surgical implant into the body, or other applications intended to support or sustain life, or for any other application in which the failure of the Motorola product could create a situation where personal injury or death may occur. Should Buyer purchase or use Motorola products for any such unintended or unauthorized application, Buyer shall indemnify and hold Motorola and its officers, employees, subsidiaries, affiliates, and distributors harmless against all claims, costs, damages, and expenses, and reasonable attorney fees arising out of, directly or indirectly, any claim of personal injury or death associated with such unintended or unauthorized use, even if such claim alleges that Motorola was negligent regarding the design or manufacture of the part. Motorola and  are registered trademarks of Motorola, Inc. Motorola, Inc. is an Equal Opportunity/Affirmative Action Employer.

How to reach us:

USA / EUROPE: Motorola Literature Distribution;
P.O. Box 20912; Phoenix, Arizona 85036. 1-800-441-2447

JAPAN: Nippon Motorola Ltd.; Tatsumi-SPD-JLDC, Toshikatsu Otsuki,
6F Seibu-Butsuryu-Center, 3-14-2 Tatsumi Koto-Ku, Tokyo 135, Japan. 03-3521-8315

MFAX: RMFAX0@email.sps.mot.com – TOUCHTONE (602) 244-6609
INTERNET: <http://Design-NET.com>

HONG KONG: Motorola Semiconductors H.K. Ltd.; 8B Tai Ping Industrial Park,
51 Ting Kok Road, Tai Po, N.T., Hong Kong. 852-26629298

**MOTOROLA**

◇ **For More Information On This Product,
Go to: www.freescale.com**

AN1556/D

