

# A Cookbook Approach to Designing a Differential-Signal Amplifier for Sensor Applications

By Eric Jacobsen  
Systems and Applications Engineer  
Sensor Products Division  
Motorola, Inc.

## INTRODUCTION

Many sensors have millivolt-level outputs — e.g., Motorola's MPX10 pressure sensor, when powered with a 5 V supply, typically has a 58 mV dynamic range (the difference between the output at full-scale pressure and zero pressure and is commonly referred to as the "span"). Therefore, amplification is required to signal condition the sensor's output to a usable range (e.g., input to an A/D converter, etc.). This paper will show you how to properly amplify and level shift the sensor's output to customize the sensor's span for a specific application. Additionally, because sensors have process (device-to-device) variations in their zero pressure offset (commonly referred to simply as "offset") and span, this paper will also show you how to properly design the amplifier so that regardless of these process variations, the desired sensor output is still attainable. While the design procedure described here is applicable to low-level, differential-output signal sensors in general, the examples presented will be with pressure sensors.

This paper is intended for two types of situations:

**Situation 1.** Applications for which the device-to-device variations of a sensor are known from a data sheet. This paper will lead you through an easy step-by-step design procedure to design an amplifier that accommodates these device-to-device variations so that for a sensor with a specific offset and span, an easy hand calibration of two potentiometers can obtain the desired output transfer function.

**Situation 2.** The device characteristics for the specific sensor to be used in the application can be measured before placing the sensor into the circuit (i.e., the sensor's offset and span are known) so that a specific amplifier can be designed for that sensor (exact resistor values are calculated to position the offset at a desired level and to set the gain for the desired span). This is a specific case of Situation 1 that uses a simplified form of the design procedure.

*Note:* Although temperature variations in the sensor's output do impact the overall system performance, the topic of temperature compensation (either hardware or software temperature compensation) is lengthy and left for future discussion (A Cookbook Approach to Designing Temperature Compensation Circuits for Sensors?).

This paper is a "how to" paper. Although it incorporates sound engineering design principles, those principles will not be explained throughout the paper. Instead it focuses on the

mechanics of doing some simple calculations, selecting resistors, and calibrating the final circuit in a step-by-step manner. For those interested, a supplemental appendix summarizes the reasons behind the design.

Using three examples, the following will be presented in this paper:

- A flexible, minimal component, three-operational amplifier gain stage that is ideal for most differential-output signal sensors.
- A cookbook design procedure that accounts for all device-to-device variations so that a hand calibration of two potentiometers gives the desired transfer function for the application. This design procedure applies to both Situations 1 and 2; however, for Situation 2, the design procedure is simplified since no hand calibration is required.
- A step-by-step guide to resistor value calculation and selection.
- An easy-to-follow calibration procedure of the circuit you just designed. The calibration procedure only applies to Situation 1.
- Two design examples for Situation 1 will be presented.
- One design example will be presented for Situation 2 that shows you how to apply the general design procedure to this specific situation.
- A supplemental appendix that summarizes the sound engineering design principles applied to this amplifier design.

## THE STEP-BY-STEP DESIGN PROCEDURE

The following design procedure is intended to be a step-by-step, cookbook approach to designing the amplifier for a specific application. The required steps in the procedure are numbered. All that is needed is the sensor data sheet for the specific sensor to be used in the application (Situation 1) or the measured values of the offset and span of a specific sensor (Situation 2), a calculator, some paper, and a pencil.

The general design and calibration procedure apply to both Situations 1 and 2. But the entire procedure is not necessary in Situation 2 (i.e., no calibration procedure is necessary); therefore, a simplified form of the design procedure is applied to Situation 2 in a straightforward example. For either situation, the required formulas are presented in a format that lends them to a simple plug-n-chug method of calculating values for resistors, gain, etc. The formulas can easily be implemented in an Excel spreadsheet format or software program to further simplify the procedure.



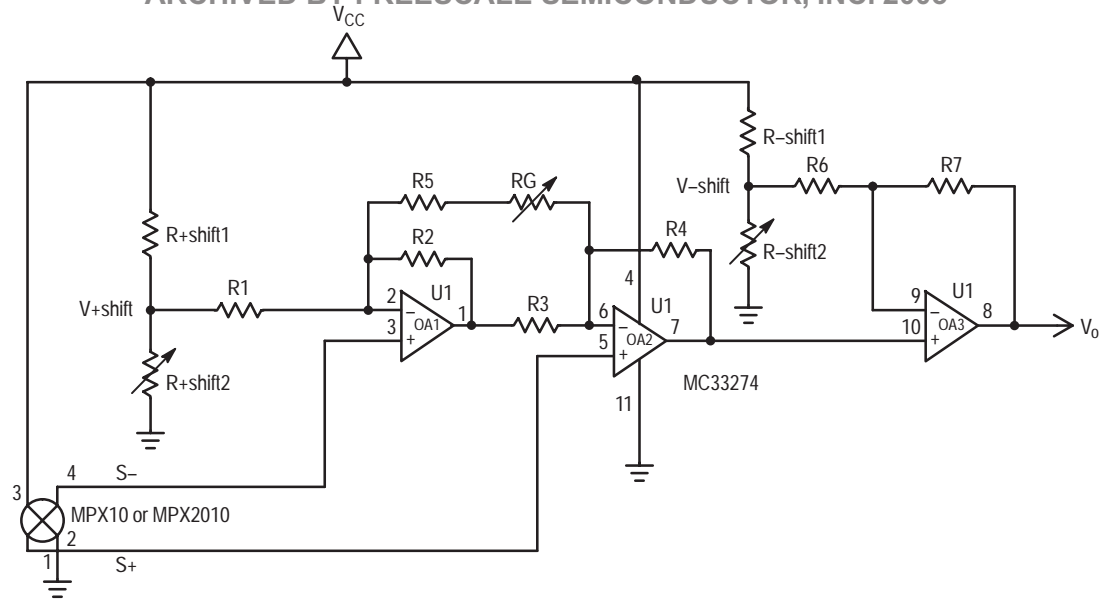

Figure 1. Three-Operational Amplifier Gain Stage with Positive and Negative Level Shifting Capability

**Situation 1: Designing the Circuit**

Figure 1 shows the recommended amplifier stage that provides excellent flexibility for most (\*\* see Important Note at the end of the Appendix) differential-output signal sensors. The circuit used for this design procedure and its examples will use a regulated  $V_{CC} = +5\text{ V}$ .

The potentiometer, RG, adjusts the gain to either calibrate or quickly customize (change) the span for a specific application.

The voltage, V+shift, created by the resistor divider comprised of R+shift1 and R+shift2 positions the offset at the desired level. For example, if after applying a desired amount of gain, the offset is 0.25 V and the desired offset is 0.50 V, then a V+shift of  $0.50\text{ V} - 0.25\text{ V} = 0.25\text{ V}$  is required. V+shift only provides a positive offset shift. Setting the voltage, V+shift, is accomplished by adjusting the potentiometer, R+shift2.

The voltage, V-shift, is similar to V+shift except that it only provides a negative level shift and is used to decrease the offset to a desired level. For example, if after applying a desired amount of gain, the offset is 1.00 V and the desired offset is 0.50 V, then a V-shift of  $1.00 - 0.50\text{ V} = 0.50\text{ V}$  is required. Setting the voltage, V-shift, is accomplished by adjusting the potentiometer, R-shift2.

During the calibration procedure, RG, R+shift2 and/or R-shift2 (depending on whether a negative or positive level shift is required to position the offset at the desired level) are the only circuit components that are adjusted to calibrate/customize the sensor's amplified offset and span.

*Step 1: Obtain the sensor data sheet.* Before designing the circuit, obtain the data sheet for the sensor. The necessary values to design the amplifier are the sensor's maximum and minimum offset values and the maximum and minimum values of its span. For the first design example, which will be presented simultaneously with each step of the design procedure, Table 1 shows the offset and span parameters for Motorola's MPX10 pressure sensor. A complete data sheet (including temperature coefficients, linearity, hysteresis, etc.) for the MPX10 can be found in Motorola's Sensor Device Data Book (DL200/D, rev. 2). The data book can be obtained by

calling Motorola's Sensor Technical Marketing at (602) 244-4556.

**Table 1. Span and Offset Characteristics at 3 V Excitation Voltage**

MPX10

Min. Span (mV)	Max. Span (mV)	Min. Offset (mV)	Max. Offset (mV)
20	50	0	35

*Step 2: Many sensors' outputs are ratiometric to the supply voltage.* Many sensors have an output that is ratiometric to the supply (excitation) voltage. Therefore, the data sheet for the sensor will indicate for what excitation voltage the span and offset values apply. The span and offset characteristics must be scaled to represent the supply voltage used in the application. The following formula is applied to each sensor characteristic that is ratiometric to the supply voltage:

$$\text{Sensor Characteristic @ Application's Supply Voltage} = \frac{\text{Sensor Characteristic Stated in Data Sheet} \times \text{Application's Supply Voltage Value}}{\text{Supply Voltage Value Stated in Data Sheet}}$$

**Table 2. Span and Offset Characteristics at 5 V Excitation Voltage**

MPX10

Min. Span (mV)	Max. Span (mV)	Min. Offset (mV)	Max. Offset (mV)
33.3	83.3	0	58.3

*Step 3: What's your desired amplified span and offset?* Each application has its own required amplified span and offset voltage. For example, if the sensor's output is to be input to an A/D converter with 0 V and 5 V reference voltages, a typical amplified sensor span is 4.0 V with an offset of 0.5 V (i.e., the sensor's span is 4.0 V beginning at 0.5 V for zero pressure to 4.5 V at full-scale pressure).

Freescale Semiconductor, Inc. ARCHIVED BY FREESCALE SEMICONDUCTOR, INC. 2005

For the MPX10 example, the sensor's output is intended to be input to an A/D as just mentioned. Therefore, the desired span is 4.0 V with an offset of 0.5 V.

*Step 4: Calculate gain range.* Calculate the maximum and minimum gains required to achieve a 4.0 V span when considering the device-to-device variations in the sensor's span.

$$\begin{aligned} \text{Maximum Gain} &= \frac{\text{Desired Span (V)}}{\text{Sensor's Minimum Span}} \\ &= \frac{4.0 \text{ V}}{33.3 \text{ mV}} = 121 \end{aligned}$$

$$\begin{aligned} \text{Minimum Gain} &= \frac{\text{Desired Span (V)}}{\text{Sensor's Maximum Span}} \\ &= \frac{4.0 \text{ V}}{83.3 \text{ mV}} = 48 \end{aligned}$$

*Step 5: Do you need a positive or negative level shift, or both?* Depending on what the range of the amplified offset voltage is due to device-to-device variations of the sensor's inherent offset, you may need a positive or negative or possibly both types of level shift to position the offset voltage at the desired level. So first calculate what the *maximum possible range* of the amplified offset is only due to the sensor's inherent offset voltage.

For the MPX10:

$$\begin{aligned} \text{Offset1} &= \text{Max. Gain} \cdot \text{Sensor's Max. Offset} \\ &= 121 \cdot 58.3 \text{ mV} = 7.05 \text{ V} \\ \text{Offset2} &= \text{Min. Gain} \cdot \text{Sensor's Min. Offset} \\ &= 48 \cdot 0 = 0.0 \text{ V} \end{aligned}$$

In this example, the maximum range between the amplified offsets is 0.0 V to 7.05 V. Therefore, depending on the specific MPX10 sensor, we will need either a positive or a negative level shift — i.e., for any offset voltage greater than 0.5 V, I will need a negative level shift to bring down the offset to 0.5 V, and for any offset voltage less than 0.5 V, I will need a positive level shift to bring up the offset to 0.5 V.

*Step 6: How much positive or negative level shift do you need?* Using Offset1 and Offset2, calculate the required level shift range.

$$\begin{aligned} V_{\pm\text{shift}} &= \text{Desired Offset} - \text{Offset1} \\ &= 0.5 \text{ V} - 7.05 \text{ V} = -6.55 \text{ V} \end{aligned}$$

$$V_{\pm\text{shift}2} = \text{Desired Offset} - \text{Offset2} = 0.5 \text{ V} - 0.0 \text{ V} = 0.5 \text{ V}$$

If the value of either  $V_{\pm\text{shift}1}$  or  $V_{\pm\text{shift}2}$  is positive, then a positive level shift is required; alternately, if the value of either  $V_{\pm\text{shift}1}$  or  $V_{\pm\text{shift}2}$  is negative, then a negative level shift is required. Therefore, in order to calibrate any randomly-selected MPX10 series sensor to have a 0.5 V offset, we may need a negative level shift (Max. V-shift) as high as 6.55 V and a positive level shift (Max. V+shift) as high as 0.5 V.

Summary of Steps 1 to 6:

Up to this point, we calculated the required gain range to establish the desired span (4.0 V in the MPX10 example) using the device-to-device variation characteristics found in the sensor's data sheet. In subsequent steps, we will determine resistor values and the value of the potentiometer,

RG, in order to adjust the amplifier's gain over the calculated gain range.

From the gain range, we calculate how the amplified offset can vary. Depending on the value of this amplified offset, a positive or negative or both types of level shift may be required to position the offset at the desired level. Again, the sensor's inherent offset variations dictate how much positive or negative level shifting is required.

Before beginning to calculate resistor values, it is helpful to tabulate the results from Steps 1 through 6 so that the values are easily accessible for the resistor calculations.

**Table 3. MPX10 Summary Data**

Max. Gain	Min. Gain	Max. V-shift (V)	Max. V+shift (V)
121	48	6.55	0.5

*Step 7: Calculate resistor values to set the gain.* A note on resistor and potentiometer selection: 1% tolerance metal thin film (low temperature coefficient) resistors are recommended. Unless noted, use the closest-valued resistor to the calculated value. For potentiometers, the more turns (i.e., how many complete turns can be made going from its zero to full-scale resistance) it has, the finer the adjustments that can be made for the gain and offset calibrations.

$$\text{Set } R7 = 10 \text{ k}\Omega$$

Before calculating R6, calculate the following ratios:

$$\text{Ratio-shift} = \frac{V_{CC}}{\text{Max. V-shift}} = \frac{5.0 \text{ V}}{6.55 \text{ V}} = 0.763$$

$$\text{Ratio+shift} = \frac{V_{CC}}{\text{Max. V+shift}} = \frac{5.0 \text{ V}}{0.5 \text{ V}} = 10$$

If Ratio+shift > Ratio-shift, then

$$\text{If } \frac{V_{CC}}{\text{Max. V-shift}} > 1, \text{ then } R6 = R7;$$

$$\text{otherwise, } R6 \leq R7 \cdot \frac{V_{CC}}{\text{Max. V-shift}}$$

If Ratio+shift < Ratio-shift, then

$$\text{If } \frac{V_{CC}}{\text{Max. V+shift}} > 1, \text{ then } R6 = R7;$$

$$\text{otherwise, } R6 \leq R7 \cdot \frac{V_{CC}}{\text{Max. V+shift}}$$

For the MPX10 example, since Ratio+shift > Ratio-shift and Ratio-shift < 1,

$$R6 \leq 10 \text{ k}\Omega \cdot \frac{5.0 \text{ V}}{6.55 \text{ V}} = 7.63 \text{ k}\Omega$$

The subsequent equations are more convenient to calculate if the ratio of R7 to R6 is an integer (e.g., 2, 3, etc. while making sure that the required "R6 ≤ . . ." equation is satisfied). Therefore, make the ratio of R7 to R6 an integer (in this example the ratio is 2):

$$R6 = 5 \text{ k}\Omega$$

Typically, set R2 = R3 = 100 Ω

For MPX10 example, R2 = R3 = 1.00 kΩ

R2 and R3, depending on the gain requirement, are typically between 100 Ω and 2 kΩ. However, the lower their values, the better (see Appendix for explanation).

$$R1 = R4 = \left[ 0.80 \cdot \frac{\text{Min. Gain}}{1 + \frac{R7}{R6}} - 1 \right] \cdot R2$$

$$= \left[ 0.80 \cdot \frac{48}{1 + \frac{10.0 \text{ k}\Omega}{5.00 \text{ k}\Omega}} - 1 \right] \cdot 1.00 \text{ k}\Omega = 11.8 \text{ k}\Omega$$

R1 and R4 should be at least 10 kΩ. Since R1 and R4 should be at least 10 kΩ, select values for R2 and R3 (keep them equal) to satisfy this constraint. It is okay to increase the values of R2 and R3 above 2 kΩ to satisfy the constraint. The explanation of this constraint is explained in the Appendix.

$$R5 = \frac{2 \cdot R4}{\frac{\text{Max. Gain}}{1 + \frac{R7}{R6}} - \frac{R4}{R2} - 1}$$

$$= \frac{2 \cdot 11.8 \text{ k}\Omega}{\frac{121}{1 + \frac{10.0 \text{ k}\Omega}{5.00 \text{ k}\Omega}} - \frac{11.8 \text{ k}\Omega}{1.00 \text{ k}\Omega} - 1} = 857 \text{ }\Omega$$

When selecting the resistor for R5, make sure its value is equal or less than the calculated value.

The maximum required value for the potentiometer is

$$RG = \frac{2 \cdot R4}{\frac{\text{Min. Gain}}{1 + \frac{R7}{R6}} - \frac{R4}{R2} - 1} - R5$$

$$= \frac{2 \cdot 11.8 \text{ k}\Omega}{\frac{48}{1 + \frac{10.0 \text{ k}\Omega}{5.00 \text{ k}\Omega}} - \frac{11.8 \text{ k}\Omega}{1.00 \text{ k}\Omega} - 1} - 857 \text{ }\Omega = 6.52 \text{ k}\Omega$$

Note on R5 and RG:

If a larger or smaller value for R5 and RG is desired, you may change the 0.80 fraction in the “R1 = R4 = . . . .” equation:

- A larger fraction (but always < 1) will result in a larger calculated value for R5 and RG.
- A smaller fraction (but not 0) will result in a smaller calculated value for R5 and RG.

*Step 8: Calculate resistor values to adjust the offset to the desired level.* The final step is to calculate the resistor values and potentiometer ranges for the level shifting (positive or negative).

*Important Note:* Power consumption through the resistor dividers that create the positive and negative level shifts has been considered so that it is kept to a moderate level at a 5 V supply. If a supply of greater than 5 V is used, please consult the Appendix on this topic.

For a positive level shift:

$$\text{Set } R+\text{shift1} = 0.1 \cdot R1 = 0.1 \cdot 11.8 \text{ k}\Omega = 1.18 \text{ k}\Omega$$

$$R+\text{shift1} = \frac{\left( \frac{\text{Max. } V+\text{shift}}{\left(1 + \frac{R7}{R6}\right) \cdot V_{CC}} \right) \cdot R+\text{shift1}}{1 - \frac{\text{Max. } V+\text{shift}}{\left(1 + \frac{R7}{R6}\right) \cdot V_{CC}}}$$

$$= \frac{\left( \frac{0.5 \text{ V}}{\left(1 + \frac{10.0 \text{ k}\Omega}{5.00 \text{ k}\Omega}\right) \cdot 5.0 \text{ V}} \right) \cdot 1.18 \text{ k}\Omega}{1 - \frac{0.5 \text{ V}}{\left(1 + \frac{10.0 \text{ k}\Omega}{5.00 \text{ k}\Omega}\right) \cdot 5.0 \text{ V}}} = 41 \text{ }\Omega$$

*Optional:* For various reasons, there are times when a potentiometer (instead of a fixed-value resistor) may be used for R+shift1 in addition to the potentiometer used for R+shift2. To give some of you the sense of completeness on this discussion, the formula is presented below:

Select potentiometer with maximum value of at least  
R+shift2 = 0.1 • R1

Use the selected maximum value of the potentiometer (not the calculated value) to calculate R+shift1:

$$R+\text{shift1} = \frac{R+\text{shift2} \cdot V_{CC}}{\frac{\text{Max. } V+\text{shift}}{1 + \frac{R7}{R6}}} - R+\text{shift2}$$

For a negative level shift:

$$\text{Set } R-\text{shift1} = 0.1 \cdot (R6 + R7)$$

$$= 0.1 \cdot (5.00 \text{ k}\Omega + 10.0 \text{ k}\Omega) = 1.50 \text{ k}\Omega$$

$$R-\text{shift1} = \frac{\left( \frac{\text{Max. } V-\text{shift}}{\frac{R7}{R6} \cdot V_{CC}} \right) \cdot R-\text{shift1}}{1 - \frac{\text{Max. } V-\text{shift}}{\left(1 + \frac{R7}{R6}\right) \cdot V_{CC}}}$$

$$= \frac{\left( \frac{6.55 \text{ V}}{\frac{10.0 \text{ k}\Omega}{5.00 \text{ k}\Omega} \cdot 5.0 \text{ V}} \right) \cdot 1.50 \text{ k}\Omega}{1 - \frac{6.55 \text{ V}}{\left(1 + \frac{10.0 \text{ k}\Omega}{5.00 \text{ k}\Omega}\right) \cdot 5.0 \text{ V}}} = 2.85 \text{ k}\Omega$$

*Optional:* For various reasons, there are times when a potentiometer (instead of a fixed-value resistor) may be used for R–shift1 in addition to the potentiometer used for R–shift2. To give some of you the sense of completeness on this discussion, the formula is presented below:

Select potentiometer with maximum value of at least  
R–shift2 = 0.1 • (R6 + R7)

Use the selected maximum value of the potentiometer (not the calculated value) to calculate R–shift1:

$$R-\text{shift1} = \frac{R-\text{shift2} \cdot V_{CC}}{\frac{\text{Max. } V-\text{shift}}{\frac{R7}{R6}}} - R-\text{shift2}$$

Table 4 summarizes the 1% resistor values for the fixed resistors and the full-scale resistance values for the potentiometers to aid in the circuit construction.

**Table 4. Resistor Values for the MPX10 Amplifier Design**

R1 (kΩ)	R2 (kΩ)	R3 (kΩ)	R4 (kΩ)	R5 (Ω)	R6 (kΩ)	R7 (kΩ)
11.8	1.00	1.00	11.8	845	5.00	10.0

RG (Pot.)	R+shift1 (kΩ)	R+shift2 (Pot.)	R-shift1 (kΩ)	R-shift2 (Pot.)
10 kΩ	1.18	50 Ω	1.50	5 kΩ

*Step 9: Go build your circuit!*

*Step 10: Calibration.* Now that you have built the circuit, it can be calibrated. The following steps are a simple procedure that calibrate the circuit. There are other calibration techniques possible, in addition to the one presented here.

First, set up the circuit as needed, connect  $V_{CC}$  (typ. 5 V), and monitor the circuit's output voltage ( $V_o$  in Figure 1) with a digital multimeter. Make sure all the potentiometers are turned to their zero-resistance setting (short circuits). Turn on the circuit's power.

1. Apply zero pressure to the sensor (or the lowest pressure to be measured in the application).
2. Adjust either R+shift2 or R-shift2 to position the offset at the desired level (in the MPX10 example, the desired offset is 0.5 V).
3. Apply the application's full-scale pressure to the sensor.
4. Adjust RG until the full-scale output is attained (in the MPX10 example, the desired full-scale output is 4.5 V — i.e., a 4.0 V span added to a 0.5 V offset).
5. When you adjust the gain, the sensor's inherent offset will be affected slightly by the gain adjustment. Therefore, the offset will have moved. Simply perform an iteration of items 1 through 4 until the desired offset and span are obtained (1 to 2 more iterations).
6. At this point, you can integrate the sensor and amplifier design into your overall system design. You may, at your option, measure the resistance values of RG, R+shift2, and R-shift2 and replace them with the closest-value 1% resistor.

### Design Example Two: From Start to Finish

This design example works through the step-by-step process with little or no explanation. It is intended to show you how simple and quick this amplifier design procedure can be.

*Step 1: Obtain the sensor data sheet.*

**Table 5. Span and Offset Characteristics at 10 V Excitation Voltage**

MPX2010

Min. Span (mV)	Max. Span (mV)	Min. Offset (mV)	Max. Offset (mV)
24	26	-1	1

*Step 2: Many sensor's outputs are ratiometric to the supply voltage.*

**Table 6. Span and Offset Characteristics at 5 V Excitation Voltage**

MPX2010

Min. Span (mV)	Max. Span (mV)	Min. Offset (mV)	Max. Offset (mV)
12	13	-0.5	0.5

*Step 3: What's your desired amplified span and offset?*

Desired offset: 0.5 V

Desired span: 4.0 V

*Step 4: Calculate the gain range.*

$$\text{Maximum Gain} = \frac{4.0 \text{ V}}{12 \text{ mV}} = 334$$

$$\text{Minimum Gain} = \frac{4.0 \text{ V}}{13 \text{ mV}} = 307$$

*Step 5: Do you need a positive or negative level shift, or both?*

$$\text{Offset1} = 334 \cdot 0.5 \text{ mV} = 0.167 \text{ V}$$

$$\text{Offset2} = 334 \cdot (-0.5 \text{ mV}) = -0.167 \text{ V}$$

*Important Note:* Notice that the Offset2 is calculated using the Maximum Gain instead of the Minimum Gain as was shown previously. Why? Remember, that we want the *largest range* in the amplified sensor offset. In this case, when one of the sensor's offsets is negative and the other positive, the largest range in the amplified sensor offset is when both Offset1 and Offset2 are calculated using the maximum gain.

*Step 6: How much positive or negative level shift do you need?*

$$V_{\pm\text{shift1}} = 0.5 \text{ V} - (-0.167 \text{ V}) = 0.667 \text{ V}$$

$$V_{\pm\text{shift2}} = 0.5 \text{ V} - 0.167 \text{ V} = 0.333 \text{ V}$$

Thus, only a positive level shift is required. In this case, you can define the level shifts as Max. V+shift (for 0.667 V) and Min. V+shift (for 0.333 V). Likewise, if only a negative level shift were required, you could define them, for example, as Max. V-shift (for the most negative level shift) and Min. V-shift (for the least negative level shift). For the subsequent calculations, always use Max. V+shift and Max. V-shift (not applicable in this example).

**Table 7. MPX2010 Summary Data**

Max. Gain	Min. Gain	Max. V+shift (V)	Min. V+shift (V)
334	307	0.667 V	0.333 V

*Step 7: Calculate resistor values to set the gain.*

$$R7 = 10 \text{ k}\Omega$$

Ratio-shift = Not Applicable (no negative shift required)

$$\text{Ratio+shift} = \frac{5.0 \text{ V}}{0.667 \text{ V}} = 7.496$$

Since Ratio+shift > 1,

$$R6 = R7 = 10 \text{ k}\Omega$$

$$\text{Set } R2 = R3 = 100 \Omega$$

$$R1 = R4 = \left( 0.80 \cdot \frac{307}{1 + \frac{10.0 \text{ k}\Omega}{10.0 \text{ k}\Omega}} - 1 \right) \cdot 100 = 12.2 \text{ k}\Omega$$

$$R5 = \frac{2 \cdot 12.2 \text{ k}\Omega}{\frac{334}{1 + \frac{10.0 \text{ k}\Omega}{10.0 \text{ k}\Omega}} - \frac{12.2 \text{ k}\Omega}{100 \Omega} - 1} = 551 \Omega$$

$$R_G = \frac{2 \cdot 12.2 \text{ k}\Omega}{\frac{307}{1 + \frac{10.0 \text{ k}\Omega}{10.0 \text{ k}\Omega}} - \frac{12.2 \text{ k}\Omega}{100 \Omega} - 1} - 551 \Omega = 242 \Omega$$

Step 8: Calculate resistor values to adjust the offset to the desired level.

$$R+\text{shift}1 = 0.1 \cdot 12.2 \text{ k}\Omega = 1.22 \text{ k}\Omega$$

$$R+\text{shift}2 = \frac{\left( \frac{0.667 \text{ V}}{\left( 1 + \frac{10.0 \text{ k}\Omega}{10.0 \text{ k}\Omega} \right) \cdot 5.0 \text{ V}} \right) \cdot 1.22 \text{ k}\Omega}{1 - \frac{0.667 \text{ V}}{\left( 1 + \frac{10.0 \text{ k}\Omega}{10.0 \text{ k}\Omega} \right) \cdot 5.0 \text{ V}}} = 87.2 \Omega$$

Since no negative level shift is required in this example, the terminal of R6 that connects to both R-shift1 and R-shift2 is connected to ground (i.e., the circuit does not require the resistors R-shift1 and R-shift2). Likewise, if no positive level shift were required, the terminal of R1 that connects to both R+shift1 and R+shift2 would be connected to ground.

**Table 8. Resistor Values for the MPX2010 Amplifier Design**

R1 (kΩ)	R2 (Ω)	R3 (Ω)	R4 (kΩ)	R5 (kΩ)	R6 (kΩ)	R7 (kΩ)
12.2	100	100	12.2	523	10.0	10.0

R <sub>G</sub> (Pot.)	R+shift1 (kΩ)	R+shift2 (Pot.)	R-shift1 (kΩ)	R-shift2 (Pot.)
500 Ω	1.22	100 Ω	N/A	N/A

Step 9: Go build your circuit!

Step 10: Calibration. Pick up an MPX2010, and have fun!

**Situation 2: Example Amplifier Design**

Using Motorola's MPX906 pressure sensor (see the Sensor Device Data Book for its data sheet), the example shown here uses most of the steps of the design procedure presented

before. However, since there are no device-to-device variations to consider (sensor's output characteristics have been measured), some of the equations have been simplified or are not required. Using this example as a model, you will be able to design an amplifier that exhibits the desired transfer function for your application with no hand calibration required.

*Important Note:* Even though this design procedure will show you how to accurately design the circuit so no hand calibration is necessary, resistor tolerances and op amp non-idealities may cause some error in the final output transfer function.

Since this situation requires no adjustment of potentiometers, the three op-amp circuit as presented before requires fewer components. Namely, the feedback loop with R5 and R<sub>G</sub> is eliminated. Also the potentiometers, R+shift2 and R-shift2, are replaced by fixed-value resistors. The simplified circuit, shown in Figure 2, adheres to the same constraints on resistor value selection as the circuit in Situation 1.

Step 1: Measure the specific sensor's offset and span. Because the MPX906's offset and span are ratiometric with supply voltage, make sure the device's characteristics are measured when powered with the system's intended supply voltage.

**Table 9. MPX906 Offset and Span Measurements at 5 V Excitation Voltage**

Offset (mV)	Span (mV)
-30.0	35.0

Step 2: What's your desired amplified span and offset?

$$\text{Desired offset} = 0.5 \text{ V}$$

$$\text{Desired span} = 4.0 \text{ V}$$

Step 3: Calculate the gain.

$$\text{Gain} = \frac{\text{Desired Span (V)}}{\text{Sensor's Span}} = \frac{4.0 \text{ V}}{35.0 \text{ mV}} = 114.3$$

Step 4: Do you need a positive or negative level shift? To position the sensor's offset at the desired level, a positive or negative level shift is added to the sensor's inherent offset.

First calculate the inherent offset after amplification:

$$\begin{aligned} \text{Sensor's Offset} &= \text{Gain} \cdot \text{Offset} \\ &= 114.3 \cdot -30.0 \text{ mV} = -3.43 \text{ V} \end{aligned}$$

Now calculate the positive or negative level shift (V±shift) required to position the offset at the desired level.

$$\begin{aligned} V\pm\text{shift} &= \text{Desired Offset} - \text{Sensor's Offset} \\ &= 0.5 \text{ V} - (-3.43) = 3.93 \text{ V} \end{aligned}$$

If V±shift is negative, you need a negative level shift of that magnitude; likewise, if it is positive, you need a positive level shift. For the MPX906 example, a positive level shift (V+shift) of 3.93 V is required to position the offset at 0.5 V.

To help you calculate the resistor values in subsequent steps, you will find it helpful to tabulate the results from steps 1 through 4.

**Table 10. MPX906 Summary Data**

Gain	V+shift (V)
114.3	3.93

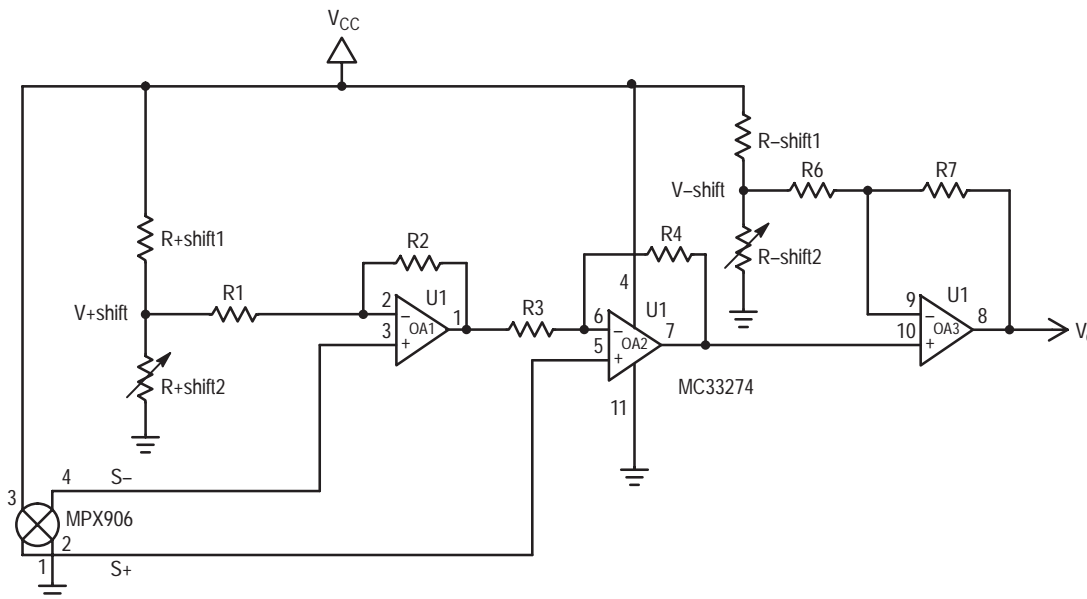

**Figure 2. Three-Operational Amplifier Gain Stage with Positive and Negative Level Shifting Capability**

*Step 5: Calculate the resistor values to set the gain.* A note on resistor selection: 1% tolerance metal thin film (low temperature coefficient) resistors are recommended. Unless noted, use the closest-valued resistor to the calculated value.

$$\text{Set } R7 = 10 \text{ k}\Omega$$

Similar to Situation 1:

$$\text{If } \left| \frac{V_{CC}}{V_{\pm \text{shift}}} \right| > 1, \text{ then } R6 = R7;$$

$$\text{otherwise, } R6 \leq R7 \quad \square \quad \left| \frac{V_{CC}}{V_{\pm \text{shift}}} \right|$$

$$\text{Since } \left| \frac{5.0 \text{ V}}{3.93 \text{ V}} \right| = 1.27 > 1$$

$$R6 = R7 = 10.0 \text{ k}\Omega$$

As in Situation 1, subsequent equations are more convenient to calculate if the ratio of R7 to R6 is an integer (e.g., 2, 3, etc. while making sure that the required “ $R6 \leq \dots$ ” equation is satisfied).

$$\text{Set } R2 = R3 = 200 \Omega$$

R2 and R3, depending on the gain requirement, are typically between 100  $\Omega$  and 2 k $\Omega$ . However, the lower their values, the better (see Appendix for explanation).

$$R1 = R4 = \left[ \frac{\text{Gain}}{1 + \frac{R7}{R6}} - 1 \right] \cdot R2$$

$$= \left[ \frac{114.3}{1 + \frac{10.0 \text{ k}\Omega}{10.0 \text{ k}\Omega}} - 1 \right] \cdot 200 = 11.2 \text{ k}\Omega$$

R1 and R4 should be at least 10 k $\Omega$ . Since R1 and R4 should be at least 10 k $\Omega$ , select values for R2 and R3 (keep them equal) to satisfy this constraint. It is okay to increase the values of R2 and R3 above 2 k $\Omega$  to satisfy the constraint. The explanation of this constraint is explained in the Appendix.

*Step 6: Calculate resistor values to adjust the offset to its desired level.* To calculate the values of the resistors to set the offset at the desired level, refer to Step 8 in Situation 1. Just replace Max. V+shift with V+shift and replace Max. V–shift with V–shift.

Referring to Step 8 of Situation 1 for the MPX906 example:

Since a positive level shift of 3.93 V is required:

$$R+\text{shift}1 = 0.1 \quad R1 = 0.1 \cdot 11.2 \text{ k}\Omega = 1.12 \text{ k}\Omega$$

$$R+\text{shift}2 = \frac{\left[ \frac{V+\text{shift}}{\left(1 + \frac{R7}{R6}\right) \cdot V_{CC}} \right] \cdot R+\text{shift}1}{1 - \frac{V+\text{shift}}{\left(1 + \frac{R7}{R6}\right) \cdot V_{CC}}}$$

$$= \frac{\left[ \frac{3.93}{\left(1 + \frac{10.0 \text{ k}\Omega}{10.0 \text{ k}\Omega}\right) \cdot 5.0 \text{ V}} \right] \cdot 1.12 \text{ k}\Omega}{1 - \frac{3.93}{\left(1 + \frac{10.0 \text{ k}\Omega}{10.0 \text{ k}\Omega}\right) \cdot 5.0 \text{ V}}} = 725 \Omega$$

Since no negative level shift is required, the terminal of R6 that connects to R–shift1 and R–shift2 should be connected to ground (i.e., R–shift1 and R–shift2 are eliminated from the circuit). Likewise, if no positive level shift were required, the terminal of R1 that connects to R+shift1 and R+shift2 should be connected to ground.

**Table 11. Resistor Values for the MPX906 Amplifier Design**

R1 (k $\Omega$ )	R2 ( $\Omega$ )	R3 ( $\Omega$ )	R4 (k $\Omega$ )	R6 (k $\Omega$ )	R7 (k $\Omega$ )	R+shift1 (k $\Omega$ )	R+shift2 ( $\Omega$ )
11.3	200	200	11.3	10.0	10.0	1.13	732 $\Omega$

*Step 7: Go build your circuit!*

**APPENDIX: THE “WHY’S” OF THE AMPLIFIER DESIGN**

The following summarizes the engineering principles used in the amplifier design.

A summary of the amplifiers' (Figures 1 and 2) transfer functions:

Both amplifiers with the given constraints exhibit excellent common mode rejection and performance.

For the amplifier in Figure 1:

By setting  $R4 = R1$  and  $R2 = R3$ ,

$$V_o = \left[ 1 + \frac{R7}{R6} \right] \cdot \left[ \left( 1 + \frac{R4}{R3} + \frac{2 \cdot R4}{R5 + R6} \right) \cdot (V_{\text{sensor}}) + V + \text{shift} \right] - \frac{R7}{R6} \cdot V\text{-shift}$$

where  $V_{\text{sensor}}$  is the voltage differential,  $S^+ - S^-$ .

For the amplifier in Figure 2:

$$\text{Setting } \frac{R4}{R3} = \frac{R1}{R2},$$

$$V_o = \left[ 1 + \frac{R7}{R6} \right] \cdot \left[ \left( 1 + \frac{R4}{R3} \right) \cdot (V_{\text{sensor}}) + V + \text{shift} \right] - \frac{R7}{R6} \cdot V\text{-shift}$$

where  $V_{\text{sensor}}$  is the voltage differential,  $S^+ - S^-$ .

For good common mode rejection (for both amplifier topologies):

- The best common mode rejection is obtained when the input impedances to the inverting and noninverting terminals of each op amp are equal.

*Note:* In order to provide the negative level shift capability in the third op amp [it also allows the circuit to provide a level shift (positive or negative) greater in magnitude than the  $V_{CC}$  by amplifying the level shift voltage created by the resistor divider], this is not optimized. Thus, depending on the input offset currents of the op amp, there will be a common mode error at the output due to the input impedance mismatch. For most applications, this error is negligible when considering most op amps have small input offset currents. For applications that require higher performance (better input impedance matching), a resistor with equal value to the input impedance of the inverting terminal of the third op amp (OA3) can be inserted between the output of the second op amp (OA2) and the noninverting input terminal of the third op amp. This discussion also applies for the first (OA1) and second op amp.

- In general, the ratio of  $R4$  to  $R3$  should equal the ratio of  $R1$  to  $R2$ . For the amplifier topology in Figure 1, more specifically,  $R1 = R4$  and  $R2 = R3$ .
- $R2$  and  $R3$  should be low in value.
- The effective parallel resistance of the resistor dividers that establish the positive and negative level shifts should be

small (at least an order of magnitude smaller) compared to  $R1$  (for  $V+$  shift) and the sum of  $(R6 + R7)$  (for  $V-$  shift).

For good amplifier dynamic range:

- A higher feedback resistance for the amplifiers (OA2 and OA3) allows the amplifier to saturate closer to its supply rails, thus giving the op amp a larger dynamic range. This is the reason for establishing  $R4$  and  $R7$  to be at least 10 k $\Omega$ .

Power dissipation in the resistor dividers used to create the level shifts:

- Power dissipation is computed as follows:

$$\text{Power} = \frac{V^2}{R}$$

Thus, if you double the supply voltage to the resistor divider, the power quadruples. In this design, the power dissipation through the resistor dividers is limited to 25 mW (at a 5 V supply). This equation will help you design your resistor dividers for higher supply voltages; however, remember that the resistor divider's effective parallel resistance should be small (compared to resistors  $R1$  and  $R6$  in these examples) for good common mode rejection.

*Important Note:* The amplifier design methodology will work for 99% of all differential output sensors; however, sensors with very large zero pressure offsets require a “special case” design methodology that may require both a positive and negative level shift in the amplifier design (in these cases there is a possibility of saturating the second amplifier). If you have an application that may be subject to this special case, please contact Sensor Marketing at (602) 244-4556 for design assistance.

**SUMMARY**

This paper presents an easy-to-follow design procedure to design a differential-signal amplifier for sensor applications. The first part (Situation 1) of the design procedure is intended for applications for which the device-to-device variations of a sensor are known from a data sheet. The design procedure then demonstrates via two examples how to design the amplifier to accommodate these device-to-device variations so that for a sensor with a specific offset and span within the distribution of offsets and spans, an easy hand calibration of two potentiometers obtains the desired output transfer function. An additional section discusses how to calibrate the amplifier for a particular sensor. The second part of the design procedure (referred to as Situation 2 and is a specific case of the first part of the design procedure) is intended for a specific sensor where its device characteristics (i.e., offset and span) are already known. Via a design example, the design procedure shows how to design the amplifier for a sensor's specific device characteristics (exact resistor values are calculated to position the offset at a desired level and to set the gain for the desired span). Finally, a summary of the amplifier design principles used in the design procedures is presented.



Motorola reserves the right to make changes without further notice to any products herein. Motorola makes no warranty, representation or guarantee regarding the suitability of its products for any particular purpose, nor does Motorola assume any liability arising out of the application or use of any product or circuit, and specifically disclaims any and all liability, including without limitation consequential or incidental damages. "Typical" parameters can and do vary in different applications. All operating parameters, including "Typicals" must be validated for each customer application by customer's technical experts. Motorola does not convey any license under its patent rights nor the rights of others. Motorola products are not designed, intended, or authorized for use as components in systems intended for surgical implant into the body, or other applications intended to support or sustain life, or for any other application in which the failure of the Motorola product could create a situation where personal injury or death may occur. Should Buyer purchase or use Motorola products for any such unintended or unauthorized application, Buyer shall indemnify and hold Motorola and its officers, employees, subsidiaries, affiliates, and distributors harmless against all claims, costs, damages, and expenses, and reasonable attorney fees arising out of, directly or indirectly, any claim of personal injury or death associated with such unintended or unauthorized use, even if such claim alleges that Motorola was negligent regarding the design or manufacture of the part. Motorola and  are registered trademarks of Motorola, Inc. Motorola, Inc. is an Equal Opportunity/Affirmative Action Employer.

**How to reach us:****USA / EUROPE:** Motorola Literature Distribution;  
P.O. Box 20912; Phoenix, Arizona 85036. 1-800-441-2447**MFAX:** RMFAX0@email.sps.mot.com – TOUCHTONE (602) 244-6609  
**INTERNET:** <http://Design-NET.com>**JAPAN:** Nippon Motorola Ltd.; Tatsumi-SPD-JLDC, Toshikatsu Otsuki,  
6F Seibu-Butsuryu-Center, 3-14-2 Tatsumi Koto-Ku, Tokyo 135, Japan. 03-3521-8315**HONG KONG:** Motorola Semiconductors H.K. Ltd.; 8B Tai Ping Industrial Park,  
51 Ting Kok Road, Tai Po, N.T., Hong Kong. 852-26629298**MOTOROLA**

---

**◇ For More Information On This Product,  
Go to: [www.freescale.com](http://www.freescale.com)**

AN1557/D

