

Micromachined Electromechanical Sensors for Automotive Applications

Prepared by Rajan Verma, Ira Baskett, and Brandon Loggins
 Motorola Sensor Products Division
 5005 East McDowell Road, MD Z210
 Phoenix, AZ 85008

Reprinted by permission Society of Automotive Engineers, Inc.

ABSTRACT

This application note is going to discuss typical requirements for micromachined sensors. The most common examples today are pressure and acceleration sensors. We will discuss the function and applications of pressure and acceleration sensors. There are two differences between accelerometers and pressure sensors: sensor technology and signal conditioning. Pressure sensors employ bulk micromachining techniques where accelerometers use surface micromachining. Pressure sensors are typically signal conditioned with bipolar circuitry. Acceleration sensors use CMOS signal conditioning. We will also explain the electrical characteristics of both pressure and acceleration sensors along with mechanical package styles. We will be focusing our effort on automotive based applications. Some typical applications for pressure sensors in the automotive environment are MAP, BAP, lumbar seat, air bag and tire pressure. The requirements of the MAP/BAP application will also be discussed in detail. Some typical applications for the acceleration sensor are front airbag, side airbag, yaw rate, active suspension and ABS. Parameter requirements for the accelerometer in a typical front airbag system will be presented.

INTRODUCTION

As the automobile enters its 2nd century of manufacture, technology continues to make it more reliable, clean and safe. Meeting tomorrow's challenges will require more sophistication. Electronics has replaced mechanical sensing with sensors that are low cost, robust and provide data to the engine control unit (ECU) that allows it to make the car fuel efficient, have low pollutant emissions and provide the occupants maximum protection in case of an accident.

There are many kinds of sensors being used to sample a larger cross-section of parameters than in the past. For example achieving optimum fuel efficiency requires mass airflow data such as temperature, barometric pressure, manifold partial vacuum, timing, and temperature but also requires correctly inflated tires.

The increased computing power in automotive applications must be fed by sensors, unlike personal computers which utilize the keyboard and mouse. The air bag sensor must act quickly to determine if a crash is occurring. Other sensors monitor constant data streams to control some aspect of passenger comfort. In both cases, solid state sensors are the key to operation of the system.

MAIN SECTION

PRESSURE SENSORS

Electrical Characteristics

Pressure sensors are used to convert pressure, a physical parameter, to an electrical signal.

The MPX series pressure sensor manufactured by Motorola is designed to be installed on a printed circuit board (standard 0.100" lead spacing) or to accept an appropriate connector if installed on a baseplate. The pressure sensor utilizes monolithic silicon piezoresistors arranged in a Wheatstone bridge configuration. The piezoresistive bridge, which functions as a strain gauge is ion implanted on a thin silicon diaphragm. Applying pressure to the diaphragm applies stress to the various piezoresistors which then change value, which in turn causes a change in the output voltage in direct proportion to the applied pressure. The strain gauge is an integral part of the silicon diaphragm, hence there are no temperature effects due to differences in thermal expansion between the strain gauge and the diaphragm. The output parameters of the strain gauge itself are temperature dependent, however, requiring that the device be compensated if used over an extensive temperature range. Simple resistor networks can be used for narrow temperatures ranges, i.e., 0°C to 85°C.

Technology

The manifold absolute pressure sensor uses a bipolar IC technology which has been refined in the automotive and consumer market place. The combination of well-proven bulk-micromachined structures and piezoresistive strain gauge transducers form a foundation for a wide range of partnerships with system and subsystem builders. Experience gained in each technology yields superior reliability, lower risk, and lower cost than any other combination at this time.

Copyright © 1998 Society of Automotive Engineers, Inc.

REV 1

The op amps are fabricated in a thick epitaxial layer, in a high voltage process which protects against unintentional over voltage and latch-up conditions. The die is protected against electrostatic discharge both during manufacturing and in operation. Short-circuit protection circuitry protects the output when shorted to either power rail.

The mechanical structure is formed by bulk micromachining with electrochemical etch-stop to produce well controlled diaphragm thickness and a tighter sensitivity distribution (see Figure 1). Thinner diaphragm targets allowed by this etch-stop have resulted in die size and attendant cost reduction. A closed bridge transducer configuration retains the process consistency of the X-ducer while providing an increased output signal. The absolute sensor vacuum reference cavity is enclosed by glass bonding a second wafer under the sensor wafer which provides additional mechanical isolation from the external package stress. Various vapor deposited films are applied to the sensor die to resist detrimental effects of the measured media and physical handling damage without creating excessive stress on the sensor diaphragm.

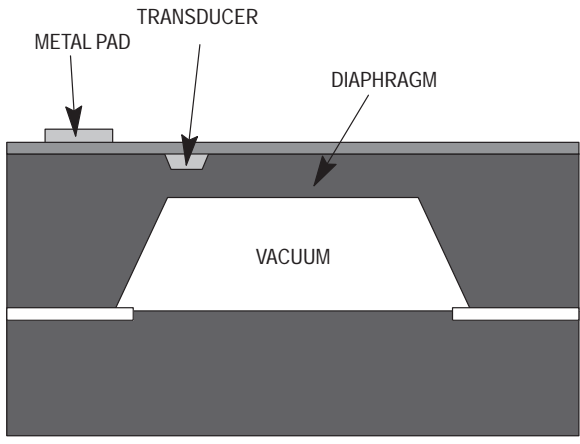

Figure 1. Pressure Sensor Cross Section

The temperature variations inherent in the piezoresistive strain gauge causes concern to the uninitiated. Some believe trim is required due to these effects. Actually, all components on bipolar integrated circuits vary with temperature. Examples are transistor betas, implanted resistor values, and junction capacitance. In fact, the base-emitter forward voltage of an IC transistor varies at a different rate with temperature if the current density is changed. Therefore, the temperature behavior of the piezoresistor is comparable to that of other IC components.

Unwanted stresses from the package, deposited films, and heavy diffusions are also suspected of requiring trim of the integrated pressure sensor.

Why do we trim pressure sensor systems? Only to remove the effects of variation. Temperature compensation of span, offset correction, ratiometricity, temperature compensation of offset and final sensitivity can all be accomplished to some degree without trim. The error is then the result of process variation. This is why pressure sensors are trimmed. Reduce the process variation and trim can be reduced or eliminated while quality, cost, and performance are improved in direct proportion.

The op amps on integrated MAP sensors are application specific. The nature of the piezoresistive strain gauge output places less stringent requirements on some parameters,

while the high level of system accuracy places a premium on others. An example is bandwidth. Since the pressure signal is a variable DC voltage, characteristics present in a high-speed video amplifier are not needed. Another characteristic of a MAP sensor is that it is operated at a fixed voltage, for example 5 volts with a tolerance variation of $\pm 7.5\%$. This is very different from a general purpose amplifier which may see supply voltages from 3 volts to 30 volts. The combined voltages of components between the power supply voltage and ground are not as critical nor are any internal parameters which vary with supply voltage, such as current drain.

One specification often ignored in the literature relating to the amplifier is ratiometricity. This is a measure of how closely the sensor output follows variations in the power supply voltage. It is a key parameter for the MAP sensor because the supply voltage also serves as the ADC Vref high voltage.

Package

Pressure sensors are offered in many different package styles, different porting options and mounting tab options. There are many types of packages available to the market, however, one of the latest package designs is the piston fit package. Piston fit packages come in three different types — the top side piston fit, the dual piston fit, as shown in Figure 2, and the backside piston fit. These packages were designed to be installed into a customer provided housing using a standard O-ring to obtain a leak proof seal. The O-ring fits over the outside of the piston fit package in the same way that a piston ring fits over the outside of a piston. Hence the name — piston fit packages. The external geometry of the top side piston fit (TPF) and the back side piston fit (BPF) packages is the same. The differences between the packages are internal. The main difference is that for the TPF, the piston fit is on the top side of the pressure die. The BPF package has the piston fit on the backside of the pressure die. The BPF is to used mainly for vacuum measurement, where the vacuum is applied to the back side of the die, or for pressure sensors that use a backside pressure exposure for media compatibility (see Figure 2-6). The dual piston fit (DPF) package is designed for use in differential or gauge pressure applications in which two unknown pressures or an unknown pressure and local atmospheric pressure are applied to either side of the sensor die.

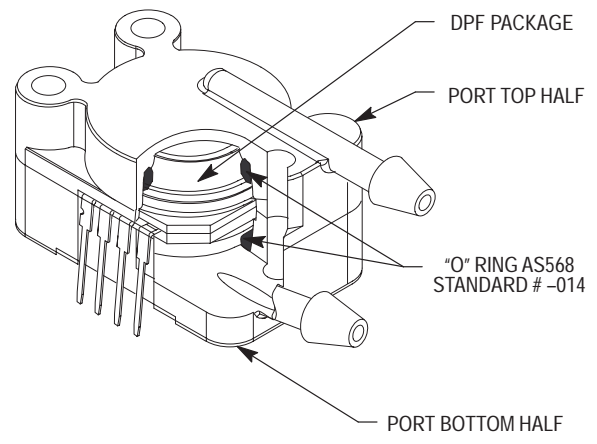

Figure 2. Dual Piston Fit Package Custom Housing

Freescale Semiconductor, Inc. ARCHIVED BY FREESCALE SEMICONDUCTOR, INC. 2005

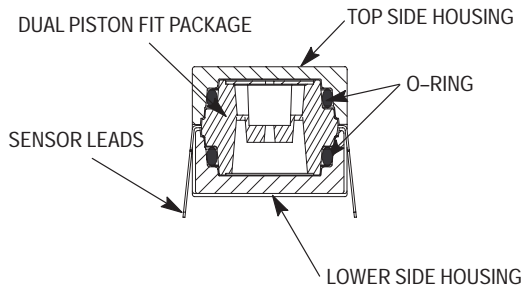

Figure 3. Dual Piston Fit Custom Housing Cross Section

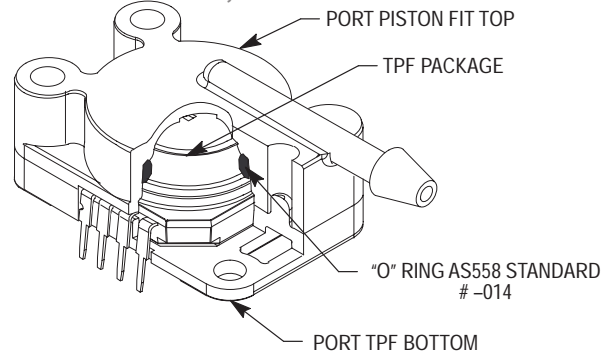

Figure 4. Top Side Piston Fit Custom Housing

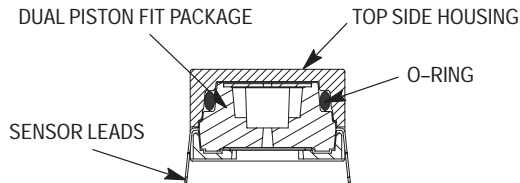
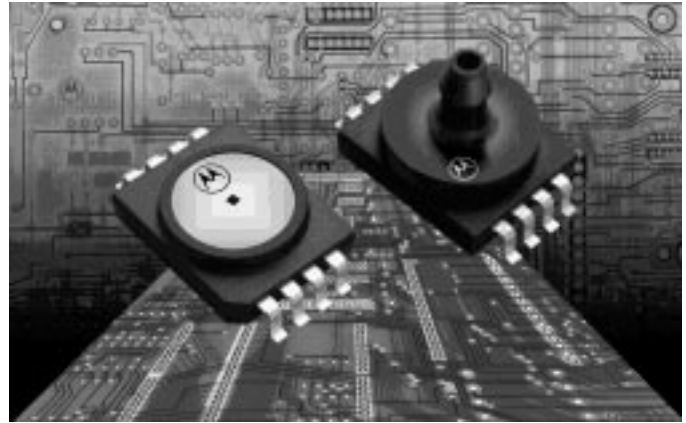

Figure 5. Top Side Piston Fit Custom Housing Cross Section



**Figure 6. Piston Fit Packages
 Top Piston Fit (l) & Top Piston Fit with Stove Pipe Port (r)**

Typical Applications

There are three types of pressure sensors: differential, gauge, and absolute. Differential pressure sensors measure the difference in the simultaneous pressure applied to both sides of the sensor. A typical automotive application might be using pressure measurement to determine when an air cleaner is dirty. By measuring the difference in pressure from the air intake side of the filter to the outlet side, the resulting pressure drop indicates the condition of the filter. The gauge pressure sensor differs from the differential design because one side is in contact with the atmosphere. One example of gauge measurement is tire pressure.

In the absolute pressure sensor, only one side is accessible,

measuring input pressure in relation to zero pressure (a total vacuum on one side of the diaphragm). Examples of applications for absolute pressure sensors include altimeters and manifold (MAP) and barometric (BAP) atmospheric pressure measurement. MAP sensors measure the partial vacuum in the intake manifold. When the engine goes through an intake cycle, a given cylinder receives the fuel-air charge from the intake manifold. The pressure measurement from the intake manifold is provided to the engine control unit, which then calculates the MAP(mass air flow) rate from the pressure measurement. As shown in Figure 7 below threaded port is installed directly in the manifold while the external mount requires the pressure hose to connect the vacuum to the sensor diaphragm.

Freescale Semiconductor, Inc. ARCHIVED BY FREESCALE SEMICONDUCTOR, INC. 2005

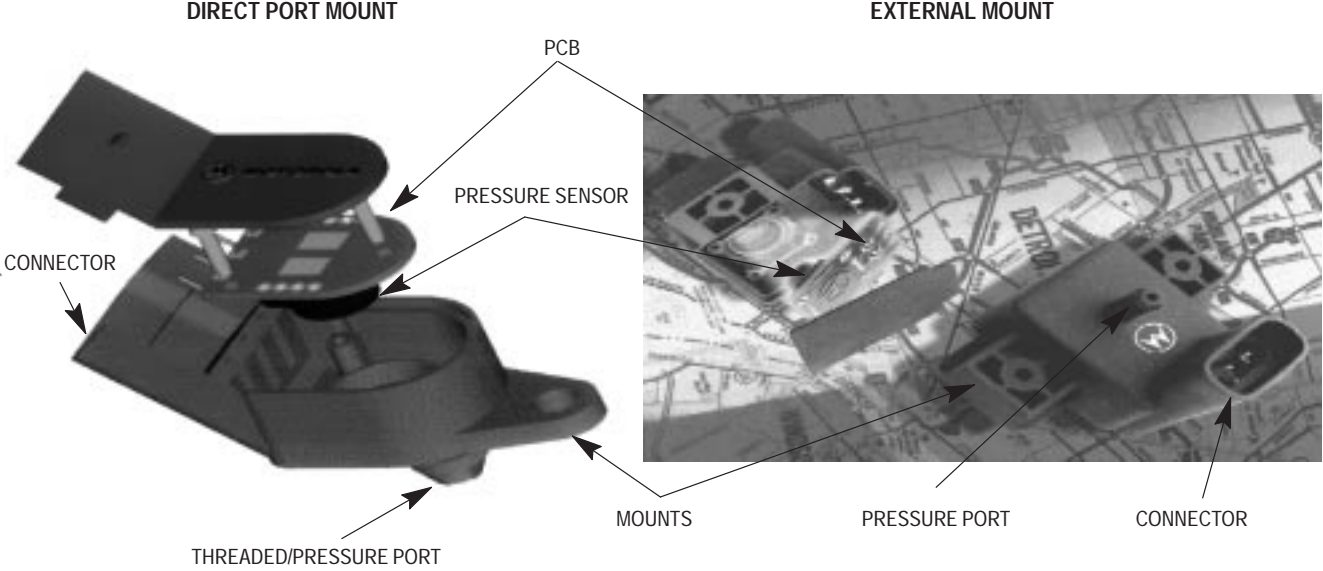

Figure 7. Direct Mount (l) and External Mount (r)

ACCELERATION SENSOR

Electrical Characteristics

Accelerometers are used to convert acceleration, a physical parameter, to an electrical signal. A microcontroller uses the signal to determine whether or not the automobile is in a crash and the intensity of the crash.

The CMOS control circuitry for surface micromachined acceleration sensors often use switched capacitor technology, extensive dynamic filtering, op amp gain stages, digital logic, and industry proven EPROM calibration.

An accelerometer typically uses a capacitive sensing technique to measure the amount of acceleration. A variable capacitor is created in silicon using surface micromachining. One type of variable capacitor consists of a movable mass suspended between two fixed capacitor plates. This mass moves according to acceleration of the device. The result is a change in capacitance that can be measured with a variety of methods.

One such method is using a switched capacitor technique to convert the change in capacitance to a change in voltage. Because of a such a small change in value (on the order of femto Farads), a custom control IC, either monolithic on the same silicon as the sensor or another chip housed in the same

package with the sensor is necessary. Depending on the application, the custom control IC provides signal conditioning to set the output sensitivity, provides temperature compensation and a self test function.

In the case of an accelerometer, sensitivity is defined as what electrical signal unit, either digital or analog, that represents one g of acceleration. Many accelerometers have an analog voltage output whereby sensitivity would be defined as the amount of voltage that equates to 1 g. Most analog accelerometers specify their output in mV/g. Sensitivity is dependent on the full scale acceleration range needed in the application. Sensitivity and full scale range are closely related. Due to the limited dynamic range of the power supply, a high sensitivity accelerometer will have a lower full scale range than a lower sensitivity device. In the automotive world, accelerometer sensitivities range can vary from 1000 mV/g for low g applications such as ABS systems down to 8 mV/g for high g applications such as side impact airbag systems.

The signal conditioning circuitry provides gain for the sensitivity and low pass filter for the output. Most automotive grade accelerometers have this filter to ensure that the control IC clock frequency or mechanical resonance does not influence the output. This low pass filter's cutoff frequency is set between 400 and 1000 Hz, depending on the application.

Because the sensor and its signal conditioning are sensitive to changes in temperature, compensation is required to correct the output. Self test is a function that allows the accelerometer to be checked for normal functionality. The self test mode applies a small voltage to the sensor, resulting an electrostatic charge that forces the capacitive plate to move. This movement is measured as a change in output that is of an expected value.

The resultant output signal is a linear voltage proportional to the acceleration applied to the accelerometer. This output is ready for input to an A/D converter. At 0g of acceleration, the output voltage is nominally 2.5 V, right between the ground and 5 V rails. At full scale, 40g, using a sensitivity of 40 mV/g, the output would be 4.1 V. A minus full scale, -40g, the output would be 0.9 V.

Technology

The micromachined accelerometer *can* take a variety of forms ranging from bulk micromachined structures with piezo-resistive transducers, laser trimmed thin-film calibration, and bipolar analog circuitry to sophisticated surface micromachined structures with capacitive transducer, EPROM calibration, and CMOS mixed-signal control circuitry. The bulk micromachined version closely resembles the conventional integrated pressure sensor. The airbag accelerometer employs multiple layers of polycrystalline silicon over sacrificial oxide layers. When the oxide is etched away, the poly structure is suspended above a lower surface by a distance equal to the thickness of the oxide. Holes patterned into the oxide before depositing the poly provide anchor points to the lower structure. This method of fabrication allows multiple layers to be formed as required for a differential capacitive

transducer working in the vertical-axis with 3 poly layers (see Figure 8) or cross-axis with 2 poly layers. The moveable structure incorporates plates for the capacitive transducer, the accelerometer mass, and self-test plates for electrostatic attraction.

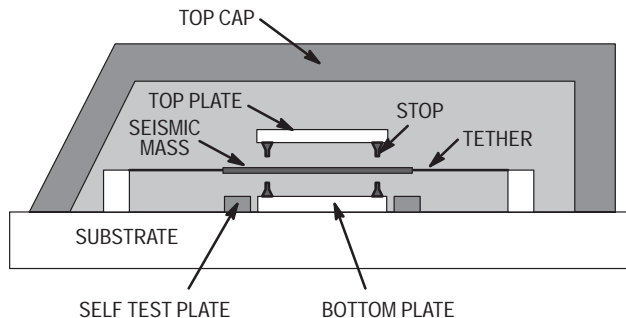

Figure 8. Accelerometer Cross Section

Packaging

Accelerometers are offered in many different packaging styles. They are offered in many standard IC packages: standard plastic DIP, plastic SOIC, ceramic DIP, ceramic SOIC and SIP. The different axis of sensing and type of sensor often dictate what package style is used. Z axis sensors are usually found in DIP or SOIC. For use as a X axis sensor, Z axis devices are sometimes turned sideways and placed into SIP packages. This requires lead frame reinforcement for mounting stability. See Figure 9. X lateral sensors are placed in DIP or SOIC devices and oriented on the PCB in the direction of desired sensing.

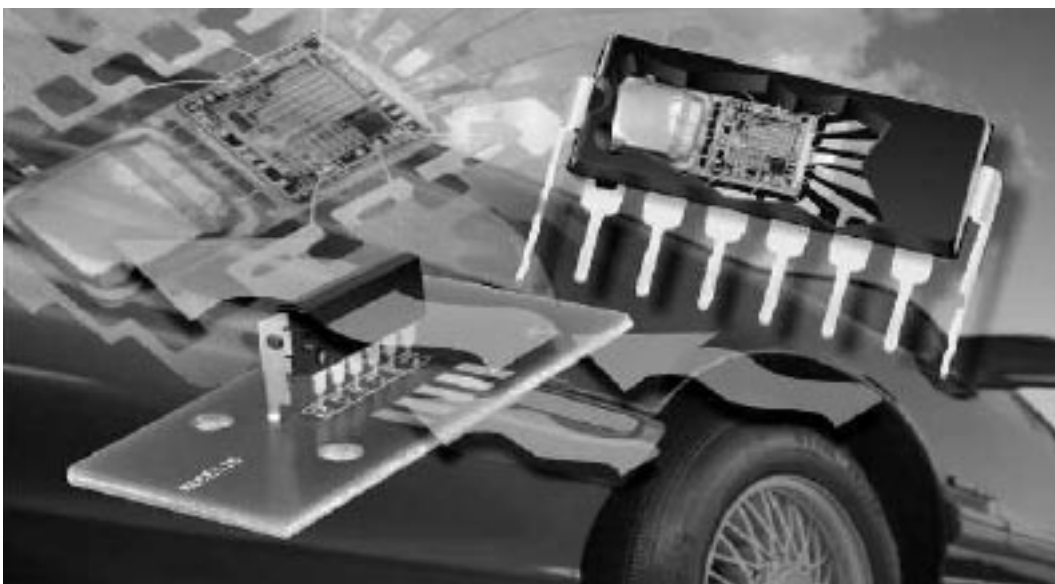

Figure 9. Automotive Accelerometer in SIP Package

Typical Applications

There are numerous automotive applications for accelerometers. The number one application today is the typical front airbag system. Airbag systems require accelerometers to determine crash severity. There are many collisions that do not require an air bag to deploy. Microcontrollers employ complex algorithms that use accelerometer data to determine the type and severity of an accident.

In a front airbag system, the accelerometer requirements are specific. The front airbag module is usually mounted in the passenger compartment. This results in a fairly large area of crush zone. In many frontal collisions, data has shown that between 20 and 40g of acceleration can be experienced in the passenger zone during a frontal collision. Thus, accelerometers with a +/- 40g full scale range are required.

Another accelerometer requirement is a low noise output. A device with less than 1 g of noise is best. In a system with an 8 bit A/D converter and an accelerometer with a sensitivity of 40 mV/g, noise above the level of 20 mV or one A/D bit is undesirable. Noise higher than that can make microcontroller algorithms more difficult to manage.

Ratiometricity is also an important requirement for the accelerometer in front airbag applications. The accelerometer output should fluctuate proportionally with the power supply. If the power supply were to dip 10%, the output should also dip 10%. The A/D converter in the system, on the same supply as the accelerometer, will also see the same variations. Its dynamic range will drop by that percentage. Therefore, if the supply were to move, the resultant digital A/D code for the acceleration at any given time would remain accurate. So even if the power supply were to fluctuate during a crash, the microcontroller could still make a decision to fire the airbags.

Another important requirement for the accelerometer is electromagnetic compatibility (EMC). The accelerometer must operate normally under certain levels of electromagnetic field exposure. Ideally, when the accelerometer is at rest (no acceleration applied), the output should be at 0g, regardless of what EMC conditions the system may be subjected to. During a duration of EMC exposure, a typical airbag system should be able to tolerate an output deviation of 1 to 3 g. A higher shift in output could create an abnormal accelerometer output, resulting in errors in the crash analysis software. This could cause the airbags to unnecessarily deploy when there is not a crash or not deploy when there is a crash.

Becoming more popular are the side-impact airbag systems. A side impact airbag system works in the same manner as frontal systems, but deals with collisions to the side of the vehicle. There are other non airbag applications in the auto-

motive world. Accelerometers can be used to determine the amount of yaw, or vehicle movement during hard cornering or loss of traction. Accelerometers are mounted in the vehicle to track motion and direction of the car. During a loss of traction or control of the vehicle, microcontrollers use the accelerometer data to determine the direction and position of the car and correct it if necessary through application of the traction control, anti-lock brakes or adjustment of the suspension settings.

In order for an anti-lock braking system (ABS) to work, the braking system electronic control unit needs to know the forward speed of the vehicle. This can be accomplished by adding an accelerometer to the system. Additionally, wheel speed sensors at each wheel allow the velocity of each wheel to be accurately determined. In practice when a vehicle is subjected to panic stops, the car's wheel(s) may lose traction and begin to "lock" under hard braking. As wheel lock begins, a wheel's speed drops very quickly relative to the car's forward motion. This information along with a velocity mathematically derived from the accelerometer data allows the ABS electronic control unit to determine how to modulate the hydraulic pressure to each brake to minimize stopping distance.

An accelerometer provides accuracy improvements over traditional speed detection methods (an often mechanical and cumbersome interface) and allows for a lower system cost and improved reliability.

CONCLUSION

Semiconductor sensors continue to expand in importance as automotive electronics provide improved efficiency, comfort, and safety. Sensors are needed to convert mechanical phenomena into an electrical signal.

Two of the most common sensors in use today are pressure sensors and accelerometers. Both employ common micromachining practices and integrated circuit technology to form efficient data collection subsystems. A wide variety of packages and porting options exist for the pressure sensor due to the specific needs of the applications. Accelerometers are offered in standard plastic packages which makes it easy to integrate into the system. MAP sensors are the most common pressure sensor automotive application while the front airbag system is the most common accelerometer application.

ACKNOWLEDGMENT

The authors would like to thank Carol Smith, David Heeley, and Randy Frank for their encouragement and valuable inputs.

Freescale Semiconductor, Inc.



Motorola reserves the right to make changes without further notice to any products herein. Motorola makes no warranty, representation or guarantee regarding the suitability of its products for any particular purpose, nor does Motorola assume any liability arising out of the application or use of any product or circuit, and specifically disclaims any and all liability, including without limitation consequential or incidental damages. "Typical" parameters which may be provided in Motorola data sheets and/or specifications can and do vary in different applications and actual performance may vary over time. All operating parameters, including "Typicals" must be validated for each customer application by customer's technical experts. Motorola does not convey any license under its patent rights nor the rights of others. Motorola products are not designed, intended, or authorized for use as components in systems intended for surgical implant into the body, or other applications intended to support or sustain life, or for any other application in which the failure of the Motorola product could create a situation where personal injury or death may occur. Should Buyer purchase or use Motorola products for any such unintended or unauthorized application, Buyer shall indemnify and hold Motorola and its officers, employees, subsidiaries, affiliates, and distributors harmless against all claims, costs, damages, and expenses, and reasonable attorney fees arising out of, directly or indirectly, any claim of personal injury or death associated with such unintended or unauthorized use, even if such claim alleges that Motorola was negligent regarding the design or manufacture of the part. Motorola and  are registered trademarks of Motorola, Inc. Motorola, Inc. is an Equal Opportunity/Affirmative Action Employer.

Mfax is a trademark of Motorola, Inc.

How to reach us:

USA/EUROPE/Locations Not Listed: Motorola Literature Distribution;
P.O. Box 5405, Denver, Colorado 80217. 1-303-675-2140 or 1-800-441-2447

JAPAN: Nippon Motorola Ltd.; SPD, Strategic Planning Office, 141,
4-32-1 Nishi-Gotanda, Shinagawa-ku, Tokyo, Japan. 81-3-5487-8488

Customer Focus Center: 1-800-521-6274

Mfax™: RMFAX0@email.sps.mot.com – TOUCHTONE 1-602-244-6609
Motorola Fax Back System – US & Canada ONLY 1-800-774-1848
– <http://sps.motorola.com/mfax/>

ASIA/PACIFIC: Motorola Semiconductors H.K. Ltd.; 8B Tai Ping Industrial Park,
51 Ting Kok Road, Tai Po, N.T., Hong Kong. 852-26629298

HOME PAGE: <http://motorola.com/sps/>



MOTOROLA

◇ **For More Information On This Product,
Go to: www.freescale.com**

AN1645/D