

ASB202 — MPX2000 Series Sensor Module

Prepared by: Bill Lucas and Warren Schultz

A plug-in module that is part of a systems development tool set for pressure sensors is presented here. It provides an analog signal from an MPX2000 series sensor to a Motorola Sensor Development Controller, or can be used stand alone to provide power and signal conditioning for the sensor.

PLUG-IN MODULE DESCRIPTION

A summary of information for using systems development plug-in module ASB202 includes the schematic in Figure 2, connector pinout in Figure 3, a pin by pin description of functionality, specs in Tables 1–3, and a parts list in Table 4. Figure 4 in the Applications section provides a quick reference for making connections. A discussion of the design appears under the heading Design Considerations.

Function

The plug-in module shown in Figure 1 is designed to supply pressure and temperature inputs to a sensor development controller. The sensor output is amplified, level shifted, filtered, and converted to a single ended signal that fits within a zero to 5 volt window. Connections are made through a DB-9 connector, which allows this board to be plugged directly into its controller. If physical separation is desired, a standard 9 wire straight-through serial cable can be inserted between the two boards. Alternately, connections for B+, 5 volts, ground, and the output signal can be made through screw terminals at the top of the board. A socket for sensor connections makes changing from one pressure range to another relatively easy.

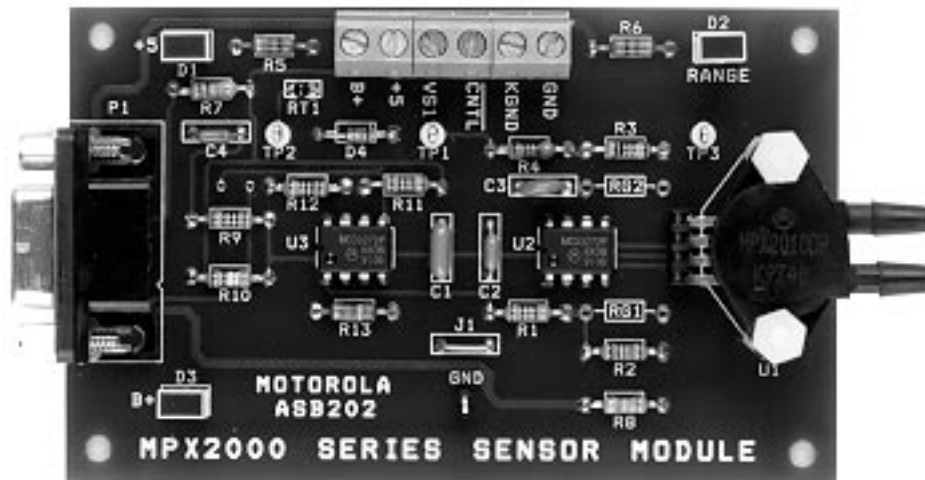

Figure 1. ASB202 — MPX2000 Series Sensor Module

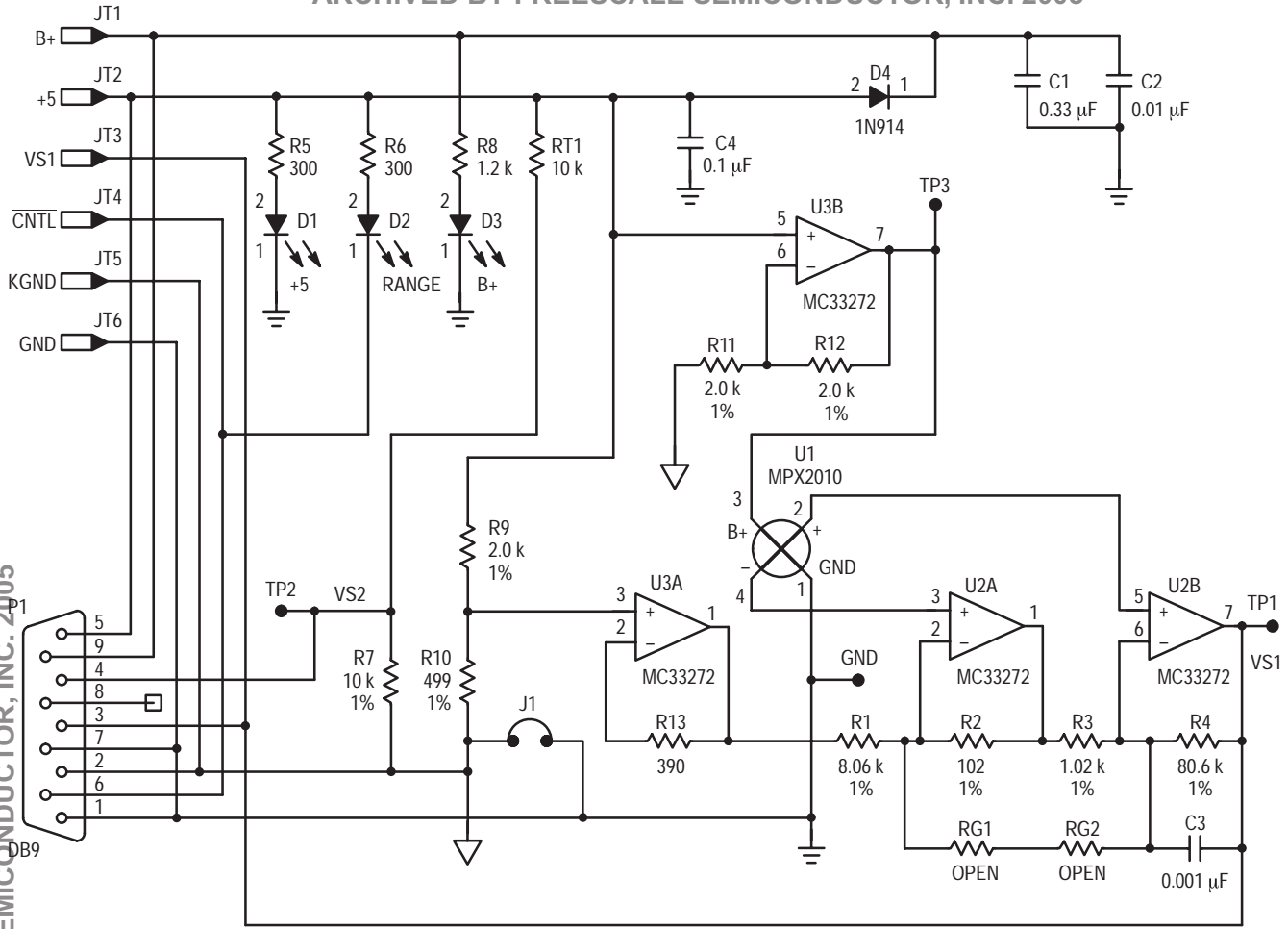

Figure 2. Schematic

Electrical Characteristics

Unless otherwise specified, the electrical characteristics in Tables 1, 2, & 3, apply to operation at 25 degrees Celsius,

B+ = 12.0 volts, and a +5 volt input of 5.00 volts. The values in Tables 2 and 3 are nominal values.

Table 1. Electrical Characteristics

Characteristic	Symbol	Min	Typ	Max	Units
DC Supply Voltage					
+5	+5	4.75	5.0	5.25	Volts
B+	B+	11.6	12	15.8	Volts
Pressure Sensor Output Voltage					
— Zero Pressure	VS1	—	1.0	—	Volt
— Full Scale (MPX2010)	—	—	3.0	—	Volts
— Full Scale (MPX2050–MPX2700)	—	—	4.2	—	Volts
Temp Sensor Output Voltage	VS2	—	2.5	—	Volts
Quiescent Current	I _{CC}	—	25	—	mA

Sensor	Full Scale Pressure (kPa)	Sensitivity (mV/kPa)	Zero Pressure Offset (Volts)	Full Scale Output Voltage (Volts)	Full Scale Span (Volts)
MPX2010*	10	200	1.0	3.0	2.0
MPX2050	50	64	1.0	4.2	3.2
MPX2100*	100	32	1.0	4.2	3.2
MPX2200	200	16	1.0	4.2	3.2

*Included with ASB202 kit

Table 3. VS2 Versus Temperature

Temperature °C	R _T Ohms	VS2 Volts	Temperature °C	R _T Ohms	VS2 Volts
0	32773	1.17	40	5323	3.26
5	25456	1.41	45	4365	3.48
10	19932	1.67	50	3599	3.68
15	15725	1.94	55	2983	3.85
20	12497	2.22	60	2486	4.00
25	10000	2.50	65	2082	4.14
30	8055	2.77	70	1753	4.25
35	6528	3.03	75	1482	4.35

Content

Board contents are described by the following parts list and the schematic in Figure 2. A pin by pin circuit description follows in the next section.

Table 4. Parts List

Item	Quantity	Reference	Part
1	1	C1	.33 μF
2	1	C2	.01 μF
3	1	C3	.001 μF
4	1	C4	.1 μF
5	3	D1,D2,D3	LED (RED)
6	1	D4	IN914
7	1	P1	DB9
8	1	RT1	10K Thermistor
9	1	R1	8.06K 1%
10	1	R2	102 1%
11	1	R3	1.02K 1%
12	1	R4	80.6K 1%
13	2	R5,R6	300
14	1	R7	10K 1%
15	1	R8	1.2K
16	3	R9,R11,R12	2.00K 1%
17	1	R10	499 1%
18	1	R13	390
19	1	U1	MPX2010
20	2	U2,U3	MC33272

Pin by Pin Description

Inputs and outputs are grouped into two connectors. A DB-9 connector provides a plug-in feature. If this connector is used, no other connections are necessary. Alternately, power, ground, and output connections can be made through screw terminals at the top of the board. The screw terminals and the DB-9 are wired in parallel. DB-9 connector pinouts are shown in Figure 3.

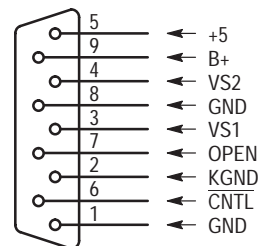

Figure 3. DB-9 Pinout

DB-9 Connector

B+:

Power for the sensor and op amps is supplied through pin 9 on the DB-9 connector. This voltage is labeled B⁺. It is specified from 11.6 VDC min to 15.8 VDC max.

+5:

5 volt power is supplied through pin 5. It is specified from 4.75 VDC min to 5.25 VDC max.

GND:

The ground connection is on pin one. It connects the sensor's analog ground to the controller's digital ground.

KGND:

An additional ground connection, labeled KGND, is made on pin 2. As shipped, KGND is tied to GND via jumper J1. If J1 is opened, KGND provides a separate signal ground return that does not carry the op amp and pressures sensor bias currents. This feature can be helpful if a cable is used between the sensor module and its controller.

VS1:

The pressure sensor output signal, VS1, is connected to pin 3. It is the output of a two op amp discrete instrumentation amplifier that has pressure sensor U1 as its input. Nominal output voltage is 1.0 volt at zero pressure and 3.0 volts at full scale with an MPX2010 sensor. With all of the other MPX2000 series sensors, nominal output voltage is 1.0 volts at zero pressure and 4.2 volts at full scale.

VS2:

A temperature dependent output signal is connected to pin 4. It is derived from a thermistor and has a nominal output voltage of 2.5 volts at 25 degrees C. The thermistor's output is a function of both ambient air temperature, and temperature rise on the board that is conducted through the leads. It will typically read several degrees higher than the temperature of still ambient air.

CNTL:

A control signal is supplied on pin 6. It is normally high, and switches low to light the RANGE light when the sensor's full scale pressure is exceeded. With code modifications, the pressure at which this transition occurs can be changed, and the signal used to control an external device.

Board Code:

A board code that lets the controller know that this is an MPX2000 series module is supplied with a ground on pin 7 and an open on pin 8.

Screw Terminals

Connections for B+, +5, VS1, CNTL, $\overline{\text{KGND}}$, & GND are wired in parallel with the DB-9 connector. As shipped, KGND and GND are tied together with Jumper J1.

Test Points TP1-TP3, & GND

Test points TP1, TP2, & TP3 provide access to output and bias signals. TP1 is connected to the pressure output signal. TP2 is connected to the thermistor output signal. The sensor's 10 volt bias voltage, supplied from op amp U3B, appears on TP3. A test point for ground is also provided.

Indicator Lights

B+:

The B+ light is provided to indicate the presence of the B+ power supply.

+5:

The +5 light is provided to indicate the presence of 5 volt power.

RANGE:

The RANGE indicator light turns on when the sensor's full scale pressure range is exceeded.

APPLICATION EXAMPLE

An application example shown in Figure 4 illustrates system connections to an ASB200 sensor development controller and a pressure source. This arrangement can be run stand alone, or the ASB200 can be connected to an MMDS or MMEVS system for code development. The two boards are designed such that the DB-9 connectors plug into each other. Once they are plugged in, it is only a matter of connecting a power supply and a pressure source to get a system up and running. If physical separation between the sensor location and the controller is desired, a standard 9 wire straight-through serial cable can be used between the two boards. Measuring different pressure ranges is facilitated by using a socket for the sensor that is supplied on the board.

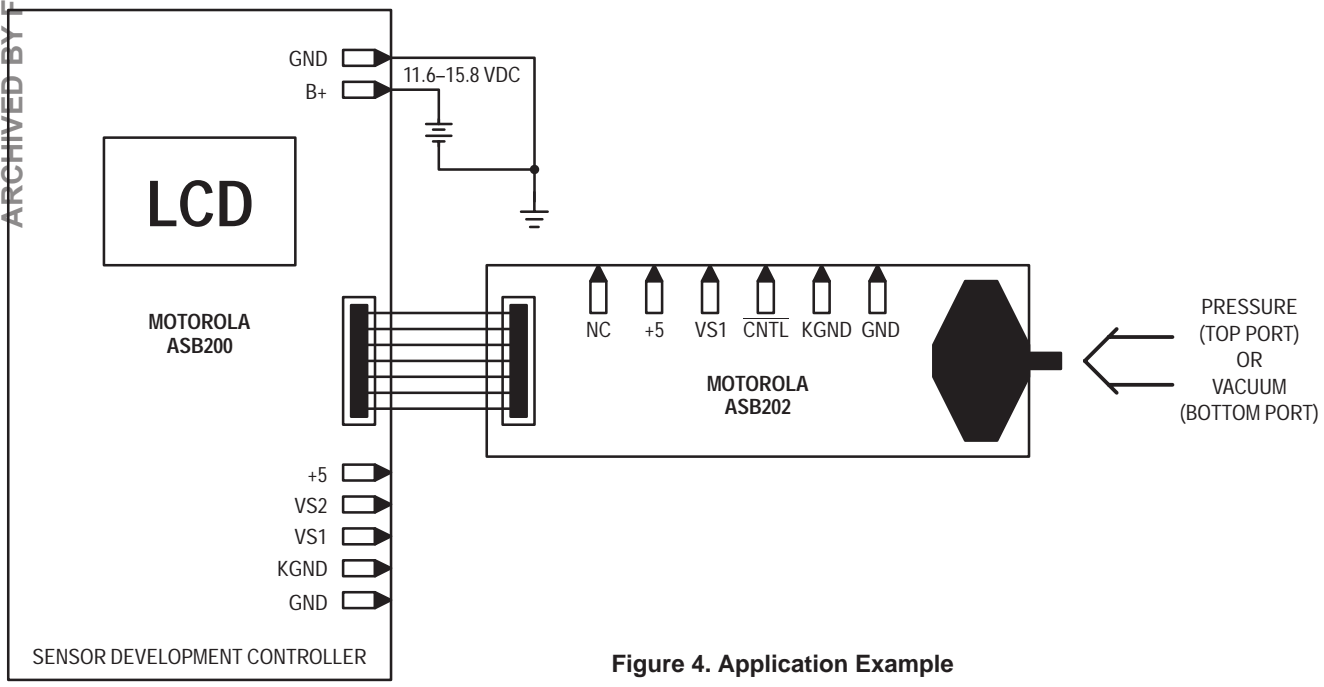

Figure 4. Application Example

Freescale Semiconductor, Inc.

When interfacing MPX2000 series pressure sensors to microcomputers, the design challenge is how to take a relatively small DC coupled differential signal and produce a ground referenced output that is suitable for driving A/D inputs. The circuit shown in Figure 2 provides a reference design performing this task.

To see how this amplifier works, let's simplify it in Figure 5, assume that the voltage source labeled V_{REF} is zero, and set the differential input voltage to zero. If the common mode voltage at sensor inputs $S+$ and $S-$ is 5.0 volts, then pin 2 of U2A and pin 6 of U2B are also at 5.0 volts. This puts 5.0 volts

across $R1$, generating $5V/8.06K = 620 \mu A$ of current. Assuming that the current in $R2$ is equal to the current in $R1$, $620 \mu A \times 102 \text{ ohms}$ produces a 63.275 mV drop across $R2$, which adds to the 5.0 volts at pin 2. The output voltage at pin 1 of U2A is, therefore, 5.063275 volts. This puts $5.063275 - 5.0$ volts across $R3$, producing $63.275mV/1.02K = 62.035 \mu A$. The same current flowing through $R4$ produces a voltage drop of $(62.035 \mu A) \times (80.6K) = 5.0$ volts, which sets the output at zero. Substituting a value for V_{REF} other than zero into this calculation reveals that the zero pressure output voltage equals V_{REF} . For this DC output voltage to be independent of the sensor's common mode voltage it is necessary to satisfy the condition that $R1/R2 = R4/R3$.

- CONSTRAINTS**
- $R4/R3 = R1/R2$
 - $R4 = 10 \text{ k MIN}$
 - $(R3 \cdot R4)/(R3 + R4) = 2 \text{ k MAX}$
 - $(R1 \cdot R2)/(R1 + R2) = 2 \text{ k MAX}$
 - $R3 \cong R2 + \text{SENSOR DELTA } Z_{OUT}$

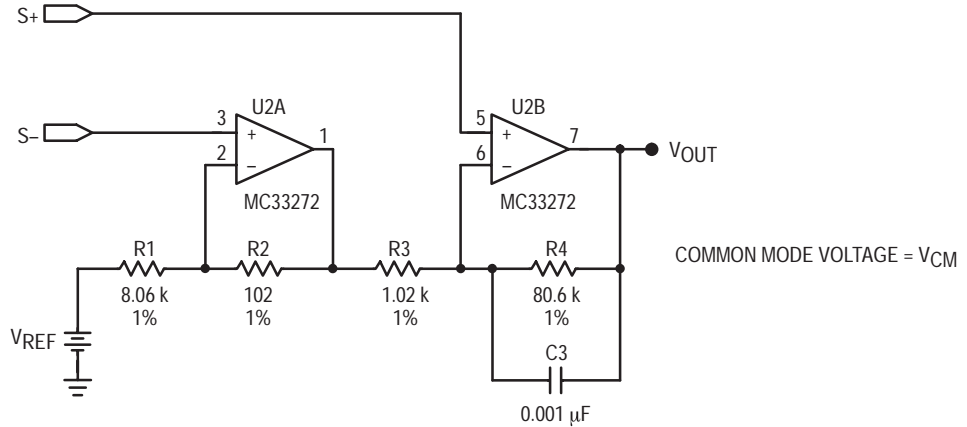

$$\text{DIFFERENTIAL GAIN} \cong R4/R3 + 1$$

$$\text{ZERO PRESSURE OFFSET} \cong V_{REF} \cdot (R2 \cdot R4)/(R1 \cdot R3) - V_{CM} \cdot ((R2 \cdot R4)/(R1 \cdot R3) - 1)$$

Figure 5. Amplifier — Simplified Schematic

Signal gain can be determined by assuming a differential output at the sensor and going through the same calculation. To do this let's assume 100 mV of differential output and $V_{REF} = 0$. These values put pin 3 of U2A at 4.95 volts, and pin 5 of U2B at 5.05 volts. Therefore, 4.95 volts is applied to $R1$, generating 614 μA . This current flowing through $R2$ produces 62.643 mV, placing pin 1 of U2A at 4950 mV + 62.6 mV = 5012.6 mV. The voltage across $R3$ is then 5050mV - 5012.6 mV = 37.4 mV, which produces a current of 37.4 mV/1.02K = 36.6 μA that flows into $R4$. The output voltage is then 5.05V + (36.6 $\mu A \cdot 80.6K$) = 8.0 volts. Dividing 8.0 volts by the 100 mV input yields a gain of 80, which provides a 3.2 volt span for 40 mV of full scale sensor output.

The foregoing nodal analysis can be summarized by the following two equations, which are first order approximations. Equation (1) assumes that the differential input between $S+$ and $S-$ in Figure 5 is zero, and that V_{CM} is the common mode voltage at $S+$ and $S-$.

(1) ZERO PRESSURE OFFSET

$$= V_{REF} \cdot (R2 \cdot R4)/(R1 \cdot R3) - V_{CM} \cdot ((R2 \cdot R4)/(R1 \cdot R3) - 1)$$

$$= 1.0(80.6K \cdot 102)/(8.06K \cdot 1020) - 5.0((80.6K \cdot 102)/(8.06K \cdot 1020) - 1)$$

$$= 1.0(8220K/8220K) - 5.0((8220K/8220K) - 1)$$

$$= 1.0 - 0 = 1 \text{ Volt}$$

(2) DIFFERENTIAL GAIN = $R4/R3 + 1$

$$= (80.6K/1.02K + 1) = 79 + 1 = 80$$

These equations are based upon the same assumptions as the nodal analysis, namely high open loop gain, zero input offset voltage, zero input bias current, and that the resistor values are actual values as opposed to specified values. As is typical in discrete instrumentation amplifiers, the most troublesome assumption is the resistor values. A 1% variation in the ratio $(R4 \cdot R2)/(R1 \cdot R3)$ causes an error that is 1% of the common mode voltage at the amplifier's input.

Returning to Figure 2, a 1.0 volt V_{REF} is generated by the divider consisting of R9 and R10. This divider is sourced from the same 5 volts as the controller's A/D converter reference, thereby minimizing power supply tolerance as a source of error. This divider is buffered by U3A in order to preserve the ratio $R4/R3 = R1/R2$. The power supply to the sensor is nominally 10.0 volts, and is also generated from the 5 volt reference to minimize power supply errors.

The resulting 1.0 V to 4.2 V output from pin 7 of U2B is compatible with microprocessor A/D inputs. Over a zero to 75 degree C temperature range combined accuracy for the

sensor and interface is $\pm 5\%$, provided that a provision for zero pressure offset calibration is made.

CONCLUSION

The ASB202 plug-in module is part of a systems development tool set for pressure sensors. It provides pressure and temperature input signals to a Motorola Sensor Development Controller, or can be used stand alone to provide a signal conditioned output from MPX2000 series sensors.



Motorola reserves the right to make changes without further notice to any products herein. Motorola makes no warranty, representation or guarantee regarding the suitability of its products for any particular purpose, nor does Motorola assume any liability arising out of the application or use of any product or circuit, and specifically disclaims any and all liability, including without limitation consequential or incidental damages. "Typical" parameters which may be provided in Motorola data sheets and/or specifications can and do vary in different applications and actual performance may vary over time. All operating parameters, including "Typicals" must be validated for each customer application by customer's technical experts. Motorola does not convey any license under its patent rights nor the rights of others. Motorola products are not designed, intended, or authorized for use as components in systems intended for surgical implant into the body, or other applications intended to support or sustain life, or for any other application in which the failure of the Motorola product could create a situation where personal injury or death may occur. Should Buyer purchase or use Motorola products for any such unintended or unauthorized application, Buyer shall indemnify and hold Motorola and its officers, employees, subsidiaries, affiliates, and distributors harmless against all claims, costs, damages, and expenses, and reasonable attorney fees arising out of, directly or indirectly, any claim of personal injury or death associated with such unintended or unauthorized use, even if such claim alleges that Motorola was negligent regarding the design or manufacture of the part. Motorola and  are registered trademarks of Motorola, Inc. Motorola, Inc. is an Equal Opportunity/Affirmative Action Employer.

Mfax is a trademark of Motorola, Inc.

How to reach us:

USA/EUROPE/Locations Not Listed: Motorola Literature Distribution;
 P.O. Box 5405, Denver, Colorado 80217. 1-303-675-2140 or 1-800-441-2447

JAPAN: Nippon Motorola Ltd.; SPD, Strategic Planning Office, 141,
 4-32-1 Nishi-Gotanda, Shinagawa-ku, Tokyo, Japan. 81-3-5487-8488

Customer Focus Center: 1-800-521-6274

Mfax™: RMFAX0@email.sps.mot.com – TOUCHTONE 1-602-244-6609
 Motorola Fax Back System – US & Canada ONLY 1-800-774-1848
 – http://sps.motorola.com/mfax/

ASIA/PACIFIC: Motorola Semiconductors H.K. Ltd.; 8B Tai Ping Industrial Park,
 51 Ting Kok Road, Tai Po, N.T., Hong Kong. 852-26629298

HOME PAGE: <http://motorola.com/sps/>



**For More Information On This Product,
 Go to: www.freescale.com**

AN1652/D