

AN1752

Data Structures for 8-Bit Microcontrollers

By Brad Bierschenk
Consumer Systems Group Applications Engineering
Austin, Texas

Introduction

A data structure describes how information is organized and stored in a computer system. Although data structures are usually presented in the context of large computers, the same principles can be applied to embedded 8-bit processors. The efficient use of appropriate data structures can improve both the dynamic (time-based) and static (storage-based) performance of microcontroller software.

This application note presents data structures which are useful in the development of microcontroller software. The applications presented here are by no means absolute. One can find an infinite variety of ways to apply these basic data structures in a microcontroller application.

Strings

A string is a sequence of elements accessed in sequential order. The string data structure usually refers to a sequence of characters. For example, a message which is to be output to a display is stored as a string of ASCII character bytes in memory.



Application Note

Storing Strings

A string of elements must be identified by a starting and ending address. A starting address for a string can be defined using an absolute address label or by using a base address of a group of strings and identifying particular strings with an offset into the group.

There are several methods of terminating string information. One common way of terminating a string is by using a special character to mark the end of the string. One terminating character to use is the value \$04, an ASCII EOT (end-of-transmission) byte.

Figure 1 shows an example of string data.

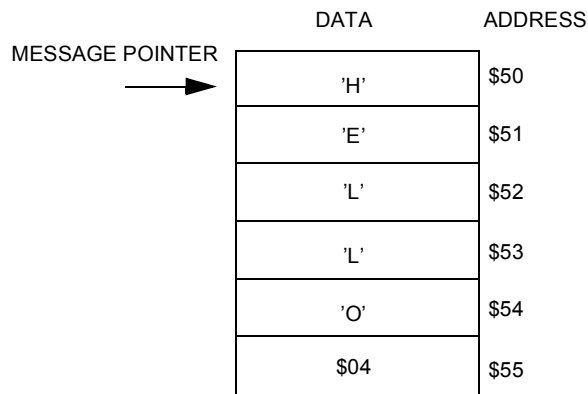

Figure 1. String Data Structure

Another method of terminating a string is to identify its length. Its length can then be used as a counter value, eliminating the need for an extra byte of storage for the end of the string.

A string of ASCII characters can be terminated without using an extra byte of storage by using the sign bit (most significant bit) as an indicator of the last byte of the string. Because ASCII character data is only seven bits long, the last byte of a string can be indicated by a 1 in its most significant bit location. When using this method, the programmer must be careful to strip off the sign bit before using the ASCII character value.

Accessing Strings An efficient way of accessing a string is with the indexed addressing mode and the INCX or DECX instruction. [Listing 1. String Storage Example](#) and [Listing 2. String Access Example](#) illustrate this string storage scheme and how to use it.

Listing 1. String Storage Example

```

*-----
* Absolute string addresses
* One way of specifying string data
*-----
Message1      FCB      'This is a string'
              FCB      $04
Message2      FCB      'This is another string'
              FCB      $04

*-----
* Indexed string addressing
* Another way of specifying string data
*-----
Msgs          EQU      *
Message3      EQU      *-Msgs
              FCB      'This is a string'
              FCB      $04
Message4      EQU      *-Msgs
              FCB      'This is another string'
              FCB      $04

```

Listing 2. String Access Example

```

*-----
* String display code
* A generic method of displaying an entire string.
*-----
LoadMsg      LDX      #Message1      ;Offset into X
Loop         LDA      Messages,X      ;Load character
              CMP     #$04           ;Check for EOT
              BEQ     StringDone      ;End of string
              JSR     ShowByte        ;Show character
              INCX   ;Point to next
              BRA     Loop

*-----
* String storage code
*-----
Messages     EQU      *
Message1     EQU      *-Messages
              FCB      'This is a string'
              FCB      $04

```

Application Note

String Applications Practical applications of strings include storing predefined "canned" messages. This is useful for applications which require output to text displays, giving users information or prompting users for input.

Strings are also effective for storing initialization strings for hardware such as modems. Strings may also store predefined command and data sequences to communicate with other devices.

Stacks

A stack is a series of data elements which can be accessed only at one end. An analogy for this data structure is a stack of dinner plates; the first plate placed on the stack is the last plate taken from the stack. For this reason, the stack is considered a LIFO (last in, first out) structure. The stack is useful when the latest data is desired. A stack will typically have a predefined maximum size.

shows a representation of a stack.

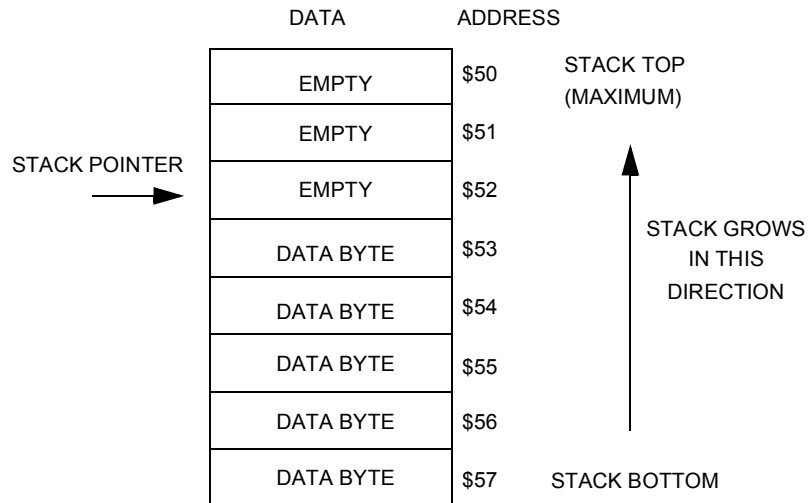

Figure 2. Stack Data Structure

Just like a physical stack of items, the software stack has a bottom and a top. Software should keep track of the location of the top of the stack. This address can either point to the first piece of valid data or it can point to the next available location. For the following examples it will be pointing to the next available location.

Stack Reading and Writing

The read operation of a stack is called "pulling" (or "popping"), and the write operation of a stack is called "pushing." When one pulls data from the stack, the data is removed from the stack and the stack pointer is adjusted. When data is pushed onto the stack, the stack pointer is adjusted and the data is added to the stack.

So, in the implementation of **Figure 2**, a push operation would first decrement the stack pointer and then store the data to the address pointed to by (stack pointer) + 1. A pull operation would retrieve the data at (stack pointer) + 1 and then increment the stack pointer.

Two error conditions are intrinsic to this data structure; underflow and overflow. A stack underflow occurs when a user attempts to pull information off an empty stack. A stack overflow occurs when a user attempts to push information onto a stack which is full. When using this data structure, these conditions should be attended to. An underflow condition should return an error. On an overflow, one can either reject the data and return an error, or the stack can "wrap" around to the bottom, destroying the data at the bottom of the stack.

MCU Hardware Stack

Freescale MCUs utilize a stack structure for saving program context before transferring program control. This interaction may be the result of a jump or interrupt. As a result of an interrupt, the stack is used to push the values in the X, A, and CCR (condition code register) registers, as well as the 16-bit PC (program counter) value. When a jump instruction is encountered, the PC value is pushed on to the stack. On returning from an interrupt (RTI instruction) the program context (registers and PC) are pulled from the stack. When returning from a jump (RTS instruction) the PC is pulled from the stack.

Application Note

Freescale Semiconductor, Inc.

HC05 Stack

The HC05 Family of MCUs have limited stack access. The only operation that can be performed with the MCU's stack pointer is to reset it. The RSP instruction will reset the stack pointer to \$FF. The HC05 stack pointer also has a limited size of 64 bytes. When the stack pointer grows beyond address \$C0, the stack pointer wraps around to \$FF, destroying any existing data at that address.

HC08 Stack

The HC08 Family of MCUs has a more flexible stack structure. The stack pointer can be set to any address. The HC08 MCUs also have an added addressing mode which is indexed by the stack pointer. In this way, a user can pass parameters to subroutines using the hardware stack, accessing the parameters using stack pointer indexed addressing.

Other HC08 Family instructions allow data to be pushed on and pulled off the stack. The stack pointer can also be transferred to the X index register and vice-versa. With the addition of these instructions and addressing modes, a user has good control over the stack in the HC08 MCU.

Stack Applications

A stack is useful for dynamically allocating memory or passing parameters to and from subroutines. Typically, MCU RAM variables are statically allocated at assembly time.

For example:

```

                                ; Statically allocated RAM variables
                                ORG      RAMSPACE
MyVar1      RMB      1
MyVar2      RMB      1
MyVar3      RMB      2
                                ; Another method to statically allocate variable
MyVar4      EQU      RAMSPACE+4
MyVar5      EQU      RAMSPACE+5

```

This is appropriate for global variables, which need to be available throughout the program flow. However, for local variables which are only used in specific subroutines, this method is not the most efficient. The RAM space these variables use can be dynamically allocated using a software stack or MCU stack, freeing up RAM memory. The same

method can be applied to subroutine input and output parameters, passing them on the stack instead of in the A or X register.

Listing 3. Software Stack shows a software implementation of a stack, which would be appropriate for the HC05 Family of microcontrollers.

Application Note

Listing 3. Software Stack

```

*-----
* STACK.ASM
* A simple software stack implementation Simply shows the PUSH and PULL operations on
* a stack; not intended to be a complete application.
* StackPtr points to next (empty) available location
* Written for the MC68HC705P6A MCU
*-----
*
* Memory map equates
*-----
RAMSPACE      EQU          $50
ROMSPACE      EQU          $100
RESETVEC      EQU          $1FFE
*-----
*
* Stack equates
*-----
STACKSIZE     EQU          $08
STACKBOT      EQU          $70          ;Bottom of software stack
STACKMAX      EQU {STACKBOT-STACKSIZE+1} ;Maximum address of stack
*-----
*
* RAM variables
*-----
StackPtr      ORG          RAMSPACE    ;First address of RAM
              RMB          1          ;Pointer to next stack byte
*-----
*
* Start of program code
*-----
Init          ORG          ROMSPACE    ;Start of ROM
              LDA          #STACKBOT   ;Initialize the stack pointer
              STA          StackPtr
*-----
*
* Some simple read and write operations
* For illustration only
*-----
              LDA          #$01
              JSR          PushA        ;Write to stack
              BCS          FullErr
              JSR          PushA        ;Write to stack
              BCS          FullErr
              JSR          PushA        ;Write to stack
              BCS          FullErr
              JSR          PushA        ;Write to stack
              BCS          FullErr
              JSR          PushA        ;Write to stack
              BCS          FullErr
              JSR          PushA        ;Write to stack
              BCS          FullErr
              JSR          PushA        ;Write to stack
              BCS          FullErr
              JSR          PushA        ;Write to stack

```



```

        BCS      FullErr
        JSR      PushA          ;Write to FULL stack
        BCS      FullErr
        JSR      PushA          ;Write to FULL stack
        BCS      FullErr
        JSR      PullA         ;Read from stack
        BCS      EmptyErr
        JSR      PullA         ;Read from stack
        BCS      EmptyErr
        JSR      PullA         ;Read from stack
        BCS      EmptyErr

Loop      BRA      *          ;Your code here

EmptyErr  BRA      *          ;Your code here
FullErr   BRA      *          ;Your code here

*-----
* Subroutines - The code to access the data structure
*-----
*
* PUSH subroutine
* Push the contents of the accumulator onto stack
* Use C bit of CCR to indicate full error
*-----
PushA     LDX      StackPtr    ;Get stack pointer
          CPX      #STACKMAX  ;Check for full stack
          BLO      Full
          DECX     ;Decrement stack pointer
          STA      1,X        ;Store data
          STX      StackPtr   ;Record new stack pointer
          CLC      ;Clear carry bit
          RTS      ;Return
Full      SEC      ;Set carry bit for error
          RTS      ;Return

*-----
* PULL subroutine
* PULL a byte off the stack into accumulator
* Use C bit of CCR to indicate empty stack error
*-----
PullA     LDX      StackPtr    ;Get stack pointer
          CPX      #STACKBOT  ;Check for empty stack
          BEQ      Empty
          LDA      1,X        ;Get data
          INCX     ;Increment stack pointer
          STX      StackPtr   ;Record stack pointer
          CLC      ;Clear carry bit
          RTS      ;Return
Empty     SEC      ;Set carry bit
          RTS      ;Return

*-----
* Vector definitions
*-----
          ORG      RESETVEC
          FDB      Init
    
```

Using the software stack, a subroutine can allocate variables by pushing (allocating) bytes on the stack, accessing them with indexed addressing (relative to the stack pointer variable) and pulling them (deallocating) before returning. In this way, the same RAM space can be used by multiple subroutines.

Parameters can be passed to and from subroutines as well. An input parameter can be pushed on the stack. When a subroutine is entered, it can access the input parameter relative to the stack pointer. By the same token, a subroutine can push an output parameter onto the stack to be passed back to the calling routine.

The MCU hardware stack and stack pointer can also be used for these purposes. Because of the expanded instruction set, the use of the MCU stack is easily exploited in the HC08 Family of microcontrollers.

Listing 4. Using the HC08 Stack Operations shows an example of using the HC08 MCU stack to pass parameters and allocate local variables.

Listing 4. Using the HC08 Stack Operations

Using the stack to pass parameters and allocate variables optimizes memory usage.

```

*-----
* Code segment example of using the HC08 stack to pass parameters and
* allocate local variables.
* Not intended to be a complete application.
*-----

```

```

LDA      #$AA      ;Load some data to be passed
PSHA    ;Push parameter for subroutine
PSHA    ;Push parameter for subroutine
JSR     Sub       ;Call subroutine
PULA    ;Parameter passed back
STA     Result2
PULA    ;Parameter passed back
STA     Result1

Loop    BRA      *      ;Your code here

```

```

*-----
* Subroutine which uses the stack for variable access
*-----
*
*   -----
* SP--->Empty
*   -----
*   LOCAL2
*   -----
*   LOCAL1
*   -----
*   PCH
*   -----
*   PCL
*   -----
*   PARAM2
*   -----
*   PARAM1
*   -----
*-----
PARAM1      EQU      6      ;Parameters passed in
PARAM2      EQU      5
LOCAL1      EQU      2      ;Local variables
LOCAL2      EQU      1
*-----
Sub          PSHA                ;Allocate local variable
           PSHA                ;Allocate local variable

           LDA      PARAM1,SP    ;Load the parameter passed in
           ROLA                ;Do something to it
           STA      LOCAL1,SP   ;Store in a local variable
           LDA      PARAM2,SP   ;Load the parameter passed in
           ROLA
           STA      LOCAL2,SP   ;Store in a local variable
           LDA      LOCAL1,SP
           STA      PARAM1,SP   ;Store value to be passed back
           LDA      LOCAL2,SP
           STA      PARAM2,SP   ;Store value to be passed back
           PULA                ;Deallocate local variable memory
           PULA                ;Deallocate local variable memory
           RTS                  ;Return

```

Queues

A queue is a series of elements which accepts data from one end and extracts data from the other end. An analogy for this data structure would be a checkout line at the supermarket. The first people in are the first people out. For this reason, it is considered a FIFO (first in, first out) structure. This is useful when accessing data in the order it is received. A queue will usually have a predefined maximum size.

Figure 3 illustrates a queue.

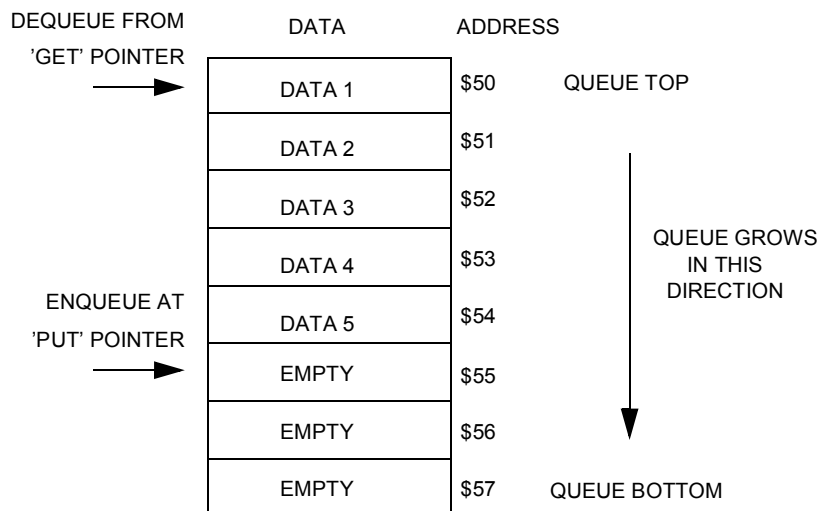

Figure 3. Queue

Reading and Writing

The read operation of a queue is called "dequeue," and the write operation is "enqueue." Two pointers are necessary for a queue, one for the head of the line, and one for the tail. For an enqueue operation, after checking the size of the queue, the data is stored at the location pointed to by the "put" pointer, and the put pointer is adjusted. For a dequeue operation, the data is read from the "get" pointer location, and the pointer is adjusted.

Queues usually have a fixed size, so it is important to keep track of the number of items in the queue. This can be done with a variable containing the size of the queue or with pointer arithmetic.

Queue Errors

As with the stack structure, a queue can be subject to underflow and overflow errors. The write, or "enqueue" operation, should be non-destructive and should error if the queue is full. The read, or "dequeue" operation, should be destructive (remove the data element) and should error if the queue is empty.

Queue Applications

A practical application of a FIFO queue is for a data buffer. Queues can be used as buffers for transmitted or received data and for use with printers or serial communication devices.

Listing 5. Queue Example shows an example of queue software. A good application for this would be to store data received from the SIOF (serial input/output port) for processing later.

Listing 5. Queue Example

```

*-----
* Illustrates an implementation of a queue For the 705P6A
*-----
* Register definitions

* Memory map definitions
RAMSPACE      EQU      $50
ROMSPACE      EQU      $100
RESETVEC      EQU      $1FFE

* Queue data structure definitions
* These three equates defines the data structure
* To change the queue, change the data structure,
* and not the code.
QMAX          EQU      !4           ;Maximum Q size
QTOP          EQU      $A0          ;Top of Q array
QBOT          EQU      QTOP+QMAX-1  ;Bottom of Q array

* RAM variables
                ORG      RAMSPACE
TempA         RMB      1
TempX         RMB      1

GetPtr        RMB      1           ;8-bit pointer
PutPtr        RMB      1           ;8-bit pointer
QCount        RMB      1           ;Counter for Q size

```

Application Note

```

*-----
* Start of program code
*-----
Start          ORG          ROMSPACE
InitQ          EQU          *
InitQ          LDA          #QTOP          ;Initialize Q pointers and variables
               STA          GetPtr
               STA          PutPtr
               CLR          QCount

*-----
* Write and read from the Q
* A good application of this is to place bytes received
* from the SCI into the queue, and retrieve them later
*-----
               JSR          DeQ
               LDA          #$FF
               JSR          EnQ
               SR           EnQ
               JSR          EnQ
               JSR          EnQ
               JSR          EnQ
               JSR          DeQ
               SR           DeQ
               LDA          #$55
               JSR          EnQ
               JSR          EnQ

Loop           BRA          *

*-----
* Subroutines
*-----
* EnQ - enqueues a data byte passed in accumulator A
* Checks for a full Q, and returns a set carry bit if full.
* Otherwise returns a cleared carry bit on successful enqueue.
*-----
EnQ            STX          TempX          Save X register contents
               LDX          QCount        ;Check for a full Q
               CMPX         #QMAX
               BEQ          QFull         ;Q full error
               LDX          PutPtr
               STA          0,X           ;Store the data in A
               CMPX         #QBOT        ;Check for wrap
               BEQ          WrapPut       ;Wrap the put pointer
               INCX         ;Adjust the put pointer
               BRA          EnQDone

WrapPut        LDX          #QTOP
               ;Successful enqueue

```

Freescale Semiconductor, Inc.

```

EnQDone      STX      PutPtr      ;Store new put pointer
              LDX      TempX        ;Restore X register
              INC      QCount       ;Increment count variable
              CLC      ;Clear carry bit
              RTS      ;Return
;Unsuccessful enqueue
QFull        LDX      TempX        ;Restore X register
              SEC      ;Set carry bit
              RTS      ;Return

```

```

*-----
* DeQ - Dequeue a byte from the queue, and return the byte in the accumulator A.
* If the queue is empty,
* return a set carry bit to indicate an error. Otherwise,
* return a clear carry bit and the data in A.
*-----

```

```

DeQ           STX      TempX        ;Save X register contents
              LDX      QCount       ;Check for empty Q
              CMPX     #$00
              BEQ      QEmpty
              LDX      GetPtr
              LDA      0,X
              CMPX     #QBOT        ;Check for wrap condition
              BEQ      WrapGet
              INCX
              BRA      DeQDone
WrapGet       LDX      #QTOP
              ;Successful dequeue
DeQDone       STX      GetPtr        ;Record new get pointer
              LDX      TempX        ;Restore X register
              DEC      QCount       ;Decrement Q counter
              CLC      ;Clear carry bit
              RTS      ;Return
              ;Unsuccessful dequeue
QEmpty        LDX      TempX        ;Restore X register
              SEC      ;Set carry bit
              RTS      ;Return

```

```

*-----
* Vector definitions
*-----

```

```

          ORG      RESETVEC
          FDB      Start

```

MACQ (Multiple Access Circular Queue)

A multiple access circular queue (or circular buffer) is a modified version of the queue data structure. It is a fixed-length, order-preserving data structure, and always contains the most recent entries. It is useful for data flow problems, when only the latest data is of interest. Once initialized it is always full, and a write operation always discards the oldest data.

Figure 4 depicts a MACQ.

Reading and Writing

After being initially filled, a write operation will place new data at the top of the MACQ, and shift existing data downward. The last byte will be discarded, so the result is the latest data existing in the buffer.

A read operation is non-destructive and can return any number of data bytes desired from the MACQ.

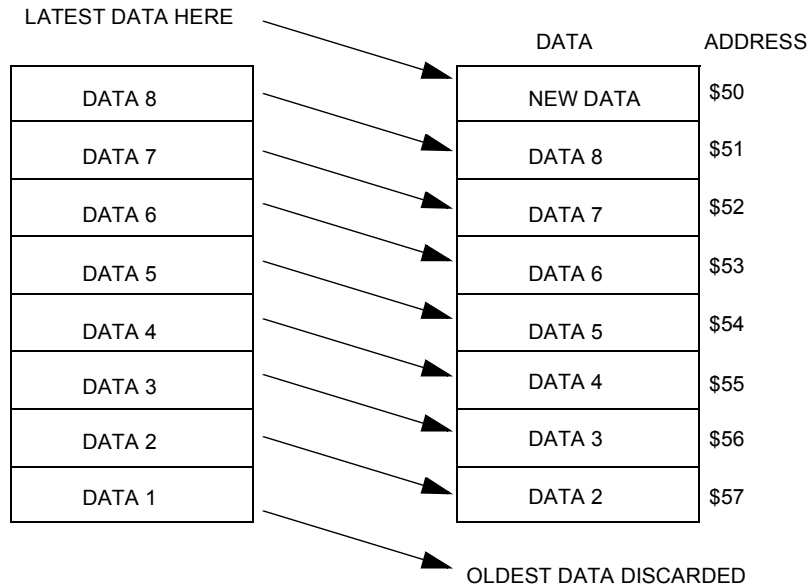

Figure 4. Result of a MACQ Write

Applications

A MACQ is useful for data streams which require the latest data and can afford to have a destructive write operation. For example, to predict the weather a forecaster might use temperature readings from the last five days to predict the next day's temperature. Daily temperature readings can be recorded in a MACQ, so the latest data is available.

MACQs are also useful for digital filters. For example, they can be used to calculate a second derivative, running average, etc.

Example

Listing 6. MACQ illustrates the implementation of a MACQ or circular buffer. This could be effectively used for storing A/D converter readings. In this way, the latest A/D conversion results would be accessible through the circular buffer.

Listing 6. MACQ

```

-----
* Illustrates an implementation of a multiple-access circular queue. (MACQ)
* The MACQ is a fixed-length, order-preserving, indexable data structure.
* Once initialized, the MACQ is always full.
* A write to the MACQ is destructive, discarding the oldest data.
* A read from the MACQ is non-destructive. For the 705P6A
-----
* Register definitions

* Memory map definitions
RAMSPACE      EQU      $50
ROMSPACE      EQU      $100
RESETVEC      EQU      $1FFE

* MACQueue data structure definitions
* These three equates defines the data structure
* To change the queue, change the data structure, and not the code.
QSIZE         EQU      8                ;Maximum Q size
QTOP          EQU      $A0              ;Top of Q array
QBOT          EQU      QTOP+QSIZE-1     ;Bottom of Q array

* RAM variables
              ORG      RAMSPACE
TempA         RMB      1
TempX         RMB      1
TempData      RMB      1
QPtr          RMB      1                ;8-bit pointer

```

Application Note

*-----
 * Start of program code
 *-----

```

Start      ORG      ROMSPACE
InitQ     EQU      *
          LDA      #QBOT      ;Initialize Q pointer
          STA      QPtr
  
```

*-----
 * Write and read from the MACQ
 * A useful application of this would be to store A/D converter readings, so the latest
 * n readings are available.
 *-----

```

          LDA      #$55
          JSR      WriteQ
          LDA      #$56
          JSR      WriteQ
          LDA      #$57
          JSR      WriteQ
          LDA      #$58
          JSR      WriteQ
          LDA      #$AA
          JSR      WriteQ
          LDA      #$AB
          JSR      WriteQ
          LDA      #$AC
          JSR      WriteQ
          LDA      #$AD
          JSR      WriteQ
          JSR      WriteQ
          LDA      #0
          JSR      ReadQ
          LDA      #1
          JSR      ReadQ
          LDA      #2
          JSR      ReadQ
  
```

```

Loop      BRA      *
  
```

*-----
 * Subroutines
 *-----

* WriteQ, A contains data to be written write is destructive on full Q, once
 initialized Q is always full.
 *-----

```

WriteQ    STX      TempX      ;Store X register value
          LDX      QPtr       ;Load Q pointer
          CMPX     #QTOP-1    ;See if Q is full
          BEQ      QFull
          STA      0,X        ;Store data to Q
  
```

```

CX                ;Decrement pointer
STX              QPtr          ;Store pointer
BRA              WQDone

* Once MACQ is initialized, it's always full
QFull            STA          TempData
LDX              QBOT-1        ;Start shifting data down
SwapLoop        LDA          0,X
STA              1,X
DECX
CMPX            #QTOP
BHS              SwapLoop
LDX              #QTOP
LDA              TempData
STA              0,X
WQDone          LDX          TempX
RTS

```

```

*-----
* ReadQ
* A contains queue index location to be read returns value in A
*-----
ReadQ            STX          TempX
ADD              #QTOP          ;A = A (index) + QTOP pointer
TAX              ;X = address of desired value
LDA              0,X
RTS

*-----
* Vector definitions
*-----
ORG              RESETVEC
FDB              Start

```

Tables

A table can be viewed as a vector of identically structured lists. A table is a common way of storing "lookup" data, such as display data or vector bytes.

Figure 5 shows an example of a table.

TOP-OF-TABLE POINTER	DATA	ADDRESS
→	\$0100	\$50
	\$0500	\$51
	\$0800	\$52
	\$0090	\$53
	\$1200	\$54
	\$2200	\$55
	\$0100	\$56
	\$0100	\$57

Figure 5. Table Representation

A table is commonly used to look up information. Table entries can be accessed with an offset from the base address of the table. Therefore, a read from a table is typically done by computing the offset of the desired data and accessing it using an indexed addressing mode.

Table Applications

The table data structure is common in MCU applications. One way of using tables is to perform character conversions. For example, a table can be used to convert binary numbers to BCD equivalents. For LCD (liquid crystal display) displays, an ASCII character byte may need to be converted to segment bitmaps for the display. A table could be used for this purpose.

Another application of a table is a "jump" table. This is a table of vector values which are addresses to be loaded and vectored to. Some program parameter can be converted to an offset into a jump table, so the appropriate vector is fetched for a certain input.

For example, in their memory maps Freescale MCUs have a built-in vector table, used for interrupt and exception processing. These vector tables allow preprogrammed addresses to be defined for certain MCU exceptions. When an exception occurs, a new program counter value is fetched from the appropriate table entry.

Another way of utilizing the table data structure is to store predefined values for lookup. An example of this is storing interpolation data in a table, to perform mathematical functions. This use of a table is documented in the application note, *M68HC08 Integer Math Routines*, Freescale document order number AN1219.

Another example involves using a table of sinusoidal values to produce sine wave output as in the application note *Arithmetic Waveform Synthesis with the HC05/08 MCUs*, Freescale document order number AN1222. If an equation to calculate data is CPU-intensive and can be approximated with discrete values, these values can be precalculated and stored in a table. In this way, a value can be quickly fetched, saving CPU time.

Table Example

Listing 7. Table is an example of the use of tables to convert ASCII data to LCD segment values.

Listing 7. Table

```

*-----
* Code segment example of using a table to store LCD segment values
* Could be used when 2 data registers define the segment values for a display position.
* Takes in an ASCII character, converts it to an offset into the table of segment
* values, and uses the offset to access the segment bitmap values.
*-----
Loop          LDA          Character          ;Load an ASCII character
              JSR          Convert           ;Convert the character
              TAX          ;Offset into table is in A
              LDA          0,X              ;Load the first byte
              STA          LCD1             ;Store to data register
              LDA          1,X              ;Load the second byte
              STA          LCD2             ;Store to data register
              BRA          Loop            ;Repeat

*-----
* Convert ASCII character byte in A to an offset value into the table of LCD segment
* values. Valid ASCII values are (decimal): 32-47, 48-57, 65-90
*-----
Convert       CMP          #!48             ;Check for "special" character
              BLO          Special
              CMP          #!65             ;Check for numeric character
              BLO          Numeric
Alpha        CMP          #!90             ;Check for invalid value
              BHI          ConvError
  
```

Application Note

	SUB	#!39	;Convert to table offset
	BRA	ConvDone	
Special	CMP	#!32	;Check for invalid value
	BLO	ConvError	
	SUB	#!32	;Convert to table offset
	BRA	ConvDone	
Numeric	CMP	#!57	;Check for invalid value
	BHI	ConvError	
	SUB	#!32	;Convert to table offset
	RA	ConvDone	
ConvError	CLRA		;Invalid value shows as blank
ConvDone	ROLA		;Multiply offset by 2
	RTS		;2 bytes data per LCD position

- * Lookup table of LCD segment values for ASCII character values
- * Some characters can not be displayed on 15-segment LCD, so they are marked as
- * invalid, and will be displayed as a blank space.

Table	FDB		
	FDB	\$0000	; ' '
	FDB	\$0000	; '! ' INVALID
	FDB	\$0201	; ' " ' "
	FDB	\$0000	; '# ' INVALID
	FDB	\$A5A5	; '\$ ' "
	FDB	\$0000	; '% ' INVALID
	FDB	\$0000	; '& ' INVALID
	FDB	\$0001	; ' ' ' "
	FDB	\$000A	; '(' "
	FDB	\$5000	; ') ' "
	FDB	\$F00F	; '* ' "
	FDB	\$A005	; '+ ' "
	FDB	\$0000	; ', ' INVALID
	FDB	\$2004	; '- ' "
	FDB	\$0800	; '.' ' "
	FDB	\$4002	; '/' ' "
	FDB	\$47E2	; '0 ' "
	FDB	\$0602	; '1 ' "
	FDB	\$23C4	; '2 ' "
	FDB	\$2784	; '3 ' "
	FDB	\$2624	; '4 ' "
	FDB	\$21A8	; '5 ' "
	FDB	\$25E4	; '6 ' "
	FDB	\$0700	; '7 ' "
	FDB	\$27E4	; '8 ' "
	FDB	\$27A4	; '9 ' "
	FDB	\$2764	; 'A ' "
	FDB	\$8785	; 'B ' "
	FDB	\$01E0	; 'C ' "
	FDB	\$8781	; 'D ' "
	FDB	\$21E4	; 'E ' "
	FDB	\$2164	; 'F ' "

	FDB	\$05E4	; 'G'
	FDB	\$2664	; 'H'
	FDB	\$8181	; 'I'
	FDB	\$06C0	; 'J'
	FDB	\$206A	; 'K'
	FDB	\$00E0	; 'L'
	FDB	\$1662	; 'M'
	FDB	\$1668	; 'N'
	FDB	\$07E0	; 'O'
	FDB	\$2364	; 'P'
	FDB	\$07E8	; 'Q'
	FDB	\$236C	; 'R'
	FDB	\$25A4	; 'S'
	FDB	\$8101	; 'T'
	FDB	\$06E0	; 'U'
	FDB	\$4062	; 'V'
	FDB	\$4668	; 'W'
	FDB	\$500A	; 'X'
	FDB	\$9002	; 'Y'
	FDB	\$4182	; 'Z'
EndTable	EQU	*-Table	;End of table label

Linked Lists

A list is a data structure whose elements may vary in precision. For example, a record containing a person's name, address, and phone number could be considered a list. A linked list is a group of lists, each of which contains a pointer to another list.

Figure 6 represents a linked list.

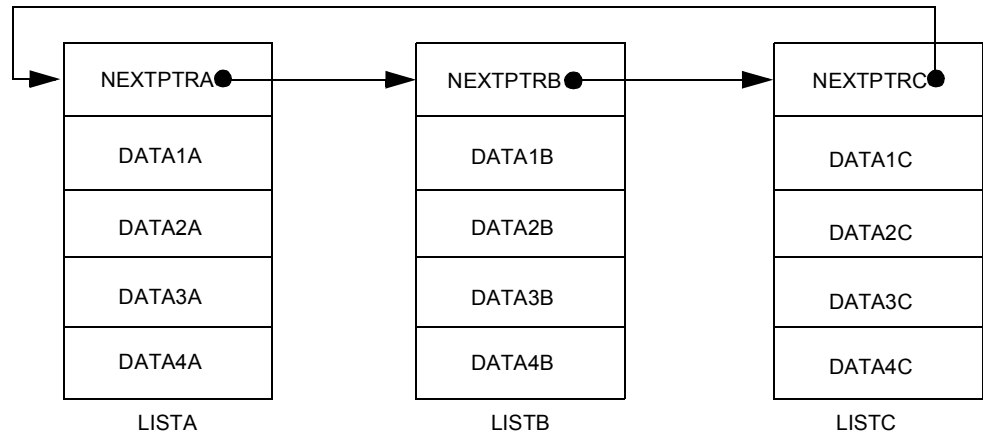

Figure 6. Linked List

Each list in the structure contains the same type of information, including a link to the next item in the list. The link might be an absolute address or an offset from some base address. In a doubly linked list, pointers are kept to both the next and the previous item in the list. A linked list can be traversed easily by simply following the pointers from one list to the next.

Linked List Applications

A linked list is used traditionally to define a dynamically allocated database, in which the elements can be ordered or resorted by adjusting the links. However, in a small microcontroller, there are more appropriate applications of linked lists.

A linked list can be used as a structure for a command interpreter. Each command could contain the string of characters, an address of a subroutine to call on that command, and a link to the next command in the linked list. In this way, a command string could be input, searched for in a linked list, and appropriate action taken when the string is found.

State Machines

Another useful application of a linked list is to define a state machine. A state machine can be represented by a discrete number of states, each of which has an output and pointers to the next state(s). See [Figure 7](#).

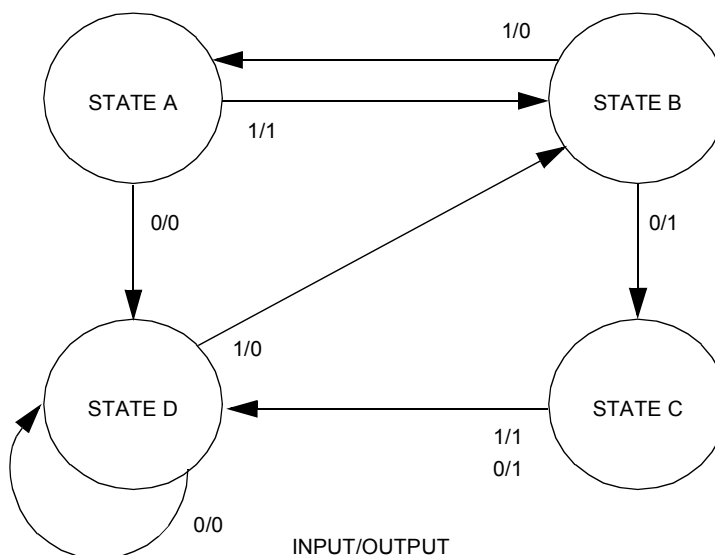

Figure 7. State Machine

A state machine can be considered a Mealy or a Moore machine. A Mealy machine’s output is a function of both its inputs and its current state. A Moore machine has an output dependent only on its current state.

This state machine model can be useful for controlling sequential devices such as vending machines, stepper motors, or robotics. These machines have a current internal state, receive input, produce output, and advance to the next state.

One can first model a process as a sequential machine, then convert this behavior to a linked-list structure and write an interpreter for it. An important goal is to be able to make modifications to the state machine by changing the data structure (linked list) and not the code.

State Machine Example

As an example, consider a traffic light controller which determines the light patterns for an intersection. Two light patterns are needed, one for the north/south directions and one for the east/west directions. Consider that the bulk of traffic travels on the north/south road, but sensors are placed at the east/west road intersection to determine when traffic needs to cross. See [Figure 8](#).

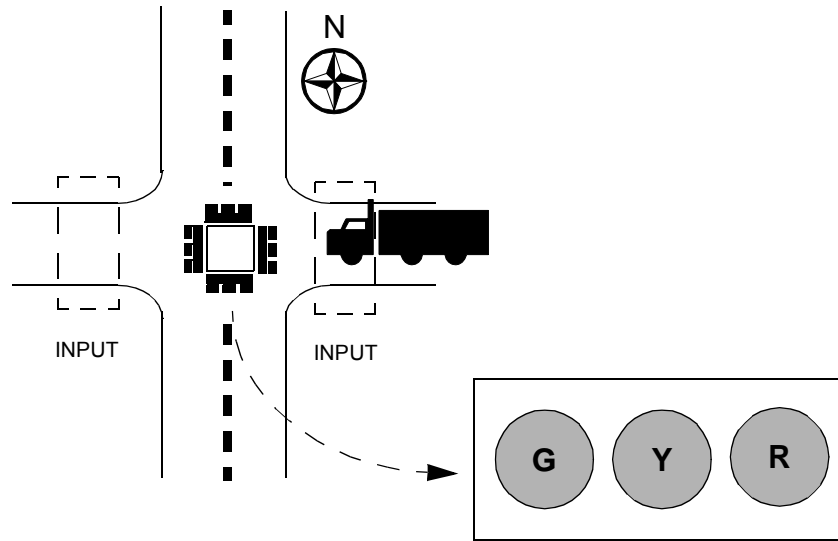

Figure 8. Traffic Light Controller Example

This example can be modeled as a Moore state machine, with its output a function of its current state. The next state is a function of the current state and the state of the input. **Figure 9** shows a state graph for this example. The initial state will be a green light in the north/south direction and a red light in the east/west direction. The controller remains in this state, until input is seen in the east/west direction. The flow continues as shown in the diagram. The output shown in the diagram is a pattern for the light array to activate the lights for the state.

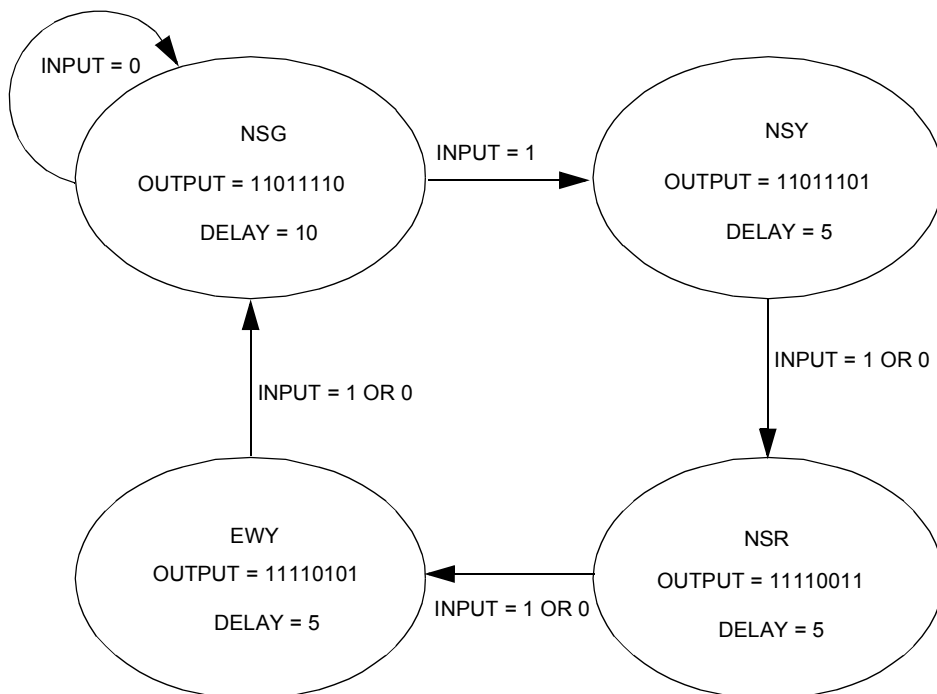

Figure 9. Traffic-Light Controller State Graph

Simulation

This example can be simulated using LEDs and a 68HC705P6A MCU. A pushbutton switch can be used to simulate the input sensor. [Figure 10](#) illustrates the simulation circuit. Using six bits of an output port, a pattern can be generated to display the appropriate north/south and east/west lights (LEDs). [Table 1](#) shows the bitmap in this application.

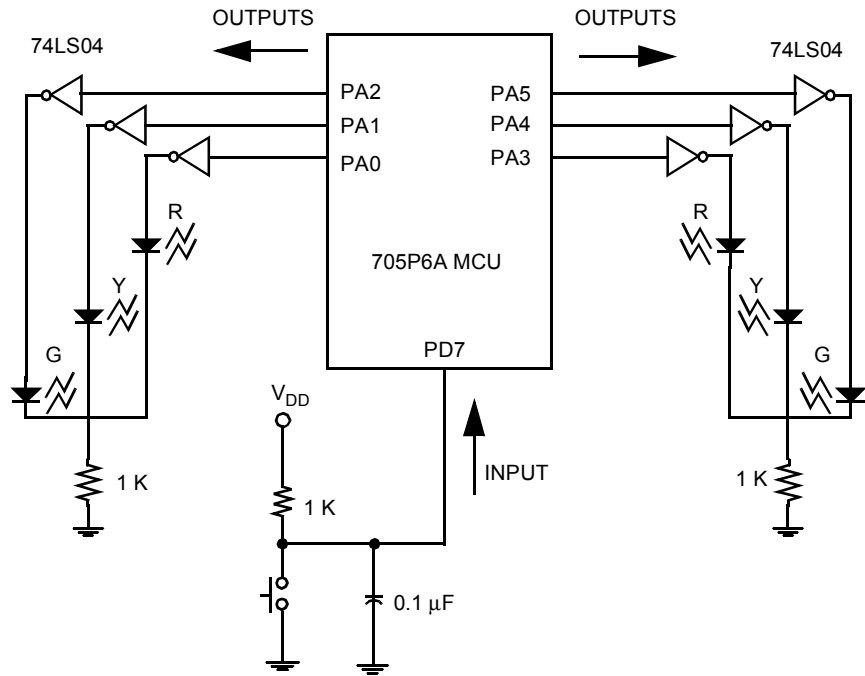

Figure 10. Circuit Simulation of Traffic-Light Controller

Table 1. Traffic Light Bitmap for Port A

Bit Position	7	6	5	4	3	2	1	0
Meaning	Not used		North/South Signal			East/West Signal		
	X	X	G	Y	R	G	Y	R

With the hardware in place, all that is left is to define the state machine in software. This can be done by implementing a linked-list data structure and the code to access and interpret the machine.

For this particular example, each list in the data structure defines the current state of the traffic light. Each list contains:

1. The byte which is the bitmap for the lights.
2. A delay value; the time the controller remains in the state
3. The next state pointer for an input of 0
4. The next state pointer for an input of 1

The main loop of the program should execute the program flow charted in **Figure 11**. The software for this simulated traffic light controller is documented in **Listing 8. Traffic Controller State Machine**.

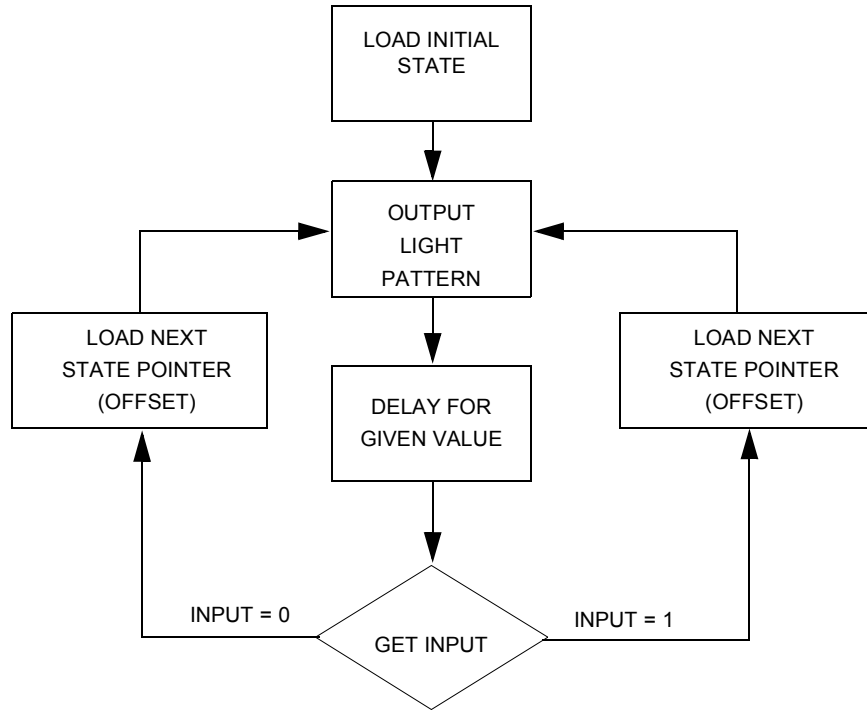

Figure 11. State Machine Program Flow

Listing 8. Traffic Controller State Machine

```

* -----
* Traffic light controller example illustrates a linked list implementation of a state
* machine For the 705P6A
* -----
* Register definitions
PORTA      EQU      $00
PORTD      EQU      $03
DDRA       EQU      $04
DDRD       EQU      $07

* Memory map definitions
RAMSPACE   EQU      $50
ROMSPACE   EQU      $100
RESETVEC   EQU      $1FFE
* RAM variables
          ORG      RAMSPACE
  
```

Application Note

```
TempA      RMB      1
TempX      RMB      1
```

```
*-----
* Start of program code
*-----
```

```
Start      ORG      ROMSPACE
           LDA      #$00
           STA      PORTA      ;Predefine output levels
           LDA      #$FF
           STA      DDRA      ;Make Port A all outputs
           BCLR     7,PORTD     ;Make Port D pin 0 an input

Loop       LDX      #INITST     ;Index initial state
           LDA      STATES+LIGHTS,X ;Get light pattern
           STA      PORTA      ;Output light pattern
           LDA      STATES+DELAY,X ;Get delay in seconds
           JSR      SecDelay     ;Cause delay
           BRCLR   7,PORTD,In0  ;Check for input of 0
In1        LDX      STATES+NEXT0,X ;Get next state offset
           BRA      Loop        ;(input = 1)
In0        LDX      STATES+NEXT1,X ;Get next state offset
           BRA      Loop        ;(input = 0)
```

```
*-----
* DATA STRUCTURE FOR STATE MACHINE LINKED LIST (05)
* Offsets and base address scheme is adequate for a small table (<255 bytes)
*-----
```

```
LIGHTS     EQU      0          ;Offset for light pattern
DELAY      EQU      1          ;Offset for time delay
NEXT0      EQU      2          ;Offset for pointer 0
NEXT1      EQU      3          ;Offset for pointer 1
STATES     EQU      *          ;Base address of states
INITST     EQU      *-STATES   ;Initial state offset
* North/South green light, East/West red light
NSG        EQU      *-STATES   ;Offset into STATES
           FCB      %11011110  ;Output for state
           FCB      !10        ;Delay for state
           FCB      NSG        ;Next state for input of 0
           FCB      NSY        ;Next state for input of 1
* N/S yellow light, E/W red light
NSY        EQU      *-STATES   ;Offset into STATES
           FCB      %11101110  ;Output for state
           FCB      !5         ;Delay for state
           FCB      NSR        ;Next state for input of 0
           FCB      NSR        ;Next state for input of 1
* N/S red light, E/W green light
NSR        EQU      *-STATES   ;Offset into STATES
           FCB      %11110011  ;Output for state
           FCB      !5         ;Delay for state
           FCB      EWY        ;Next state for input of 0
```

```

FCB          EWY
* E/W yellow light, N/S red light
EWY          EQU          *-STATES
              FCB          %11110101
              FCB          !5          ;Delay for state
              FCB          NSG
              FCB          NSG

```

*-----
* Delay subroutines
*-----

* Cause a delay of ~(1 second * Accumulator value) @ fop = 1MHz
*-----

```

SecDelay     CMP          #$00
              BEQ          SecDone
              JSR          Delay0
              JSR          Delay0
              DECA
              BRA          SecDelay
SecDone      RTS

```

*-----
* Cause a delay of ~1/2 of a second
*-----

```

Delay0       STX          TempX
              LDX          #$B2
DLoop0      CMPX         #$00
              BEQ          DDone0
              JSR          Delay1
              DECX
              BRA          DLoop0
DDone0      LDX          TempX
              RTS

```

*-----
* Cause about 2.8msec delay @ fop of 1MHz
*-----

```

Delay1       STA          TempA
              LDA          #$FF
DLoop1      CMP          #$00
              BEQ          DDone1
              DECA
              BRA          DLoop1
DDone1      LDA          TempA
              RTS

```

*-----
* Vector definitions
*-----

```

ORG          RESETVEC
FDB          Start

```

Conclusion

The use of data structures is not necessarily limited to large, complicated computers. Although the data structure is a powerful concept in such a context, the same principles can be applied to smaller processors such as 8-bit microcontrollers.

The code to implement these data structures does not necessarily have to be complex or confusing. The goal of programming should be to modularize commonly used functions, so that they may be reused in other applications with a minimal amount of modification.

The appropriate use of data structure concepts can improve the static and dynamic performance of an MCU application, without affecting its portability or legibility.

Information in this document is provided solely to enable system and software implementers to use Freescale Semiconductor products. There are no express or implied copyright licenses granted hereunder to design or fabricate any integrated circuits or integrated circuits based on the information in this document. Freescale Semiconductor reserves the right to make changes without further notice to any products herein. Freescale Semiconductor makes no warranty, representation or guarantee regarding the suitability of its products for any particular purpose, nor does Freescale Semiconductor assume any liability arising out of the application or use of any product or circuit, and specifically disclaims any and all liability, including without limitation consequential or incidental damages. "Typical" parameters which may be provided in Freescale Semiconductor data sheets and/or specifications can and do vary in different applications and actual performance may vary over time. All operating parameters, including "Typicals" must be validated for each customer application by customer's technical experts. Freescale Semiconductor does not convey any license under its patent rights nor the rights of others. Freescale Semiconductor products are not designed, intended, or authorized for use as components in systems intended for surgical implant into the body, or other applications intended to support or sustain life, or for any other application in which the failure of the Freescale Semiconductor product could create a situation where personal injury or death may occur. Should Buyer purchase or use Freescale Semiconductor products for any such unintended or unauthorized application, Buyer shall indemnify and hold Freescale Semiconductor and its officers, employees, subsidiaries, affiliates, and distributors harmless against all claims, costs, damages, and expenses, and reasonable attorney fees arising out of, directly or indirectly, any claim of personal injury or death associated with such unintended or unauthorized use, even if such claim alleges that Freescale Semiconductor was negligent regarding the design or manufacture of the part.

