

DragonBall™ Power Management

Freescale's DragonBall series of integrated processors have been widely adopted for hand-held PDA system designs. The power management of these processors is one of the key factors in the success of hand-held products. The MC68328 and MC68EZ328 are the currently available DragonBall processors, and both contain the same power control module. This application note describes the function of the power control unit in detail.

DragonBall Common Reference Platform

Figure 1 shows a common MC68EZ328-based PDA design. It includes a pen-input touch panel, an LCD panel, a communications port (RS232 or IrDA), memory, a speaker or buzzer, and a pager receiver.

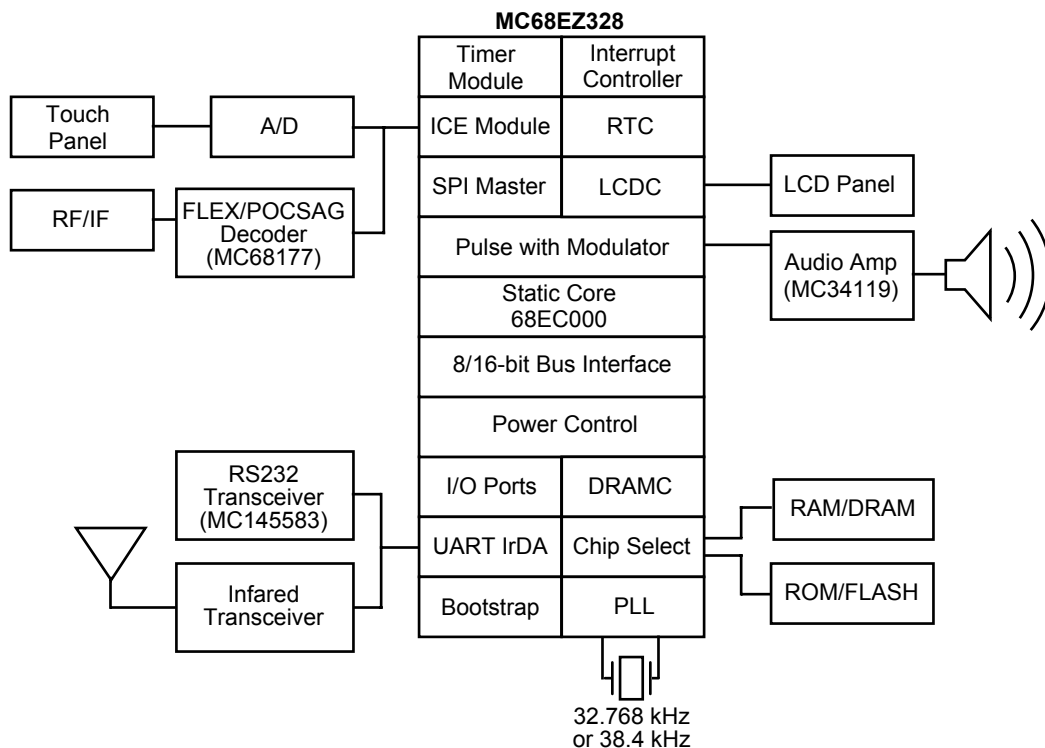

AA1912

Figure 1. MC68EZ328-Based System Example

Content Organization

Please refer to the following list for a description of this application note’s contents.

“DragonBall Common Reference Platform”	1
“Content Organization”	2
“DragonBall Power Modes”	2
“Burst Mode”	3
“DOZE Mode”	3
“Sleep Mode”	4
“Power Consumption Test”	4
“Test Hardware Set-Up”	4
“Normal Mode Test”	4
“Burst Mode Test”	5
“DOZE Mode Test”	5
“Sleep Mode Test”	6
“Conclusions”	7

DragonBall Power Modes

Based on application needs, the DragonBall can operate in any of four modes: normal mode, burst mode, DOZE mode, and sleep mode. Properly applied, power-saving techniques can result in minimal power consumption for the entire system and can thus extend battery life. The current consumption values specified in the DragonBall user’s manual represent the maximum normal mode value as well as a sleep mode value. In real-world applications, DOZE mode is used most of the time the system is up and running.

The DragonBall processors achieve power savings by minimizing bus activity while optimizing system and CPU clock frequencies. Figure 2 shows the clock tree model of the internal phase lock loop (PLL) and power management circuit.

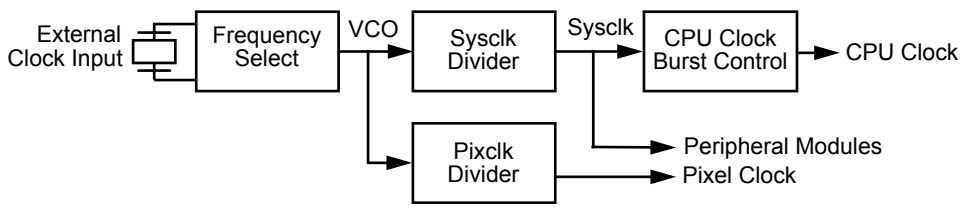

AA1913

Figure 2. Clock Tree Model of Internal PLL

Please refer to the following list for a description of the elements of Figure 2.

- External clock input—Both 32.768KHz and 38.4KHz crystals can be used as the PLL input frequency. A frequency of 32.768KHz is recommended. Throughout this application note, 32.768KHz, or simply 32KHz, will be assumed as the input reference.
- Voltage-controlled oscillator (VCO)—This is the output frequency of the PLL’s VCO. Its default output frequency, for a 32KHz input, is 16.58MHz. The VCO frequency can be changed from approximately 9MHz to 23 MHz through programming of the P and Q values of

frequency select register. Note that the VCO frequency can be maintained at its default value while achieving power saving requirements for the system.

- Sysclk—This clock signal is derived from the VCO through a divider. By default the MC68328 divides by 1, generating a Sysclk frequency of 16.58MHz after reset. By default the MC68EZ328 divides by 2 (EZ328 has a 1-bit Prescaler which is set by default), so Sysclk is Normal Mode
- 8.29MHz after reset. The Sysclk output is applied to all DragonBall peripheral modules except the RTC, which is clocked directly from the external 32KHz crystal.
- Pixel clock—This clock is used for the LCD pixel generation. It is separated from Sysclk so that changing the system-clock frequency for power saving will not affect the LCD screen refresh rate.
- CPU clock—This clock signal is input to the CPU core. Since the CPU consumes a major portion of overall power, changing the CPU clock frequency and burst duty cycle will directly affect the DragonBall power consumption.

In normal mode the system is running at its highest frequency, and the DragonBall consumes maximum power. The maximum system clock frequency for both the MC68328 and MC68EZ328 is 16.58Mhz. The 68K core performance at this frequency is 2.7 million instructions per second (MIPS). If the system requires a peak performance lower than 2.7 MIPS, a lower system clock frequency can be used by programming the system-clock divider accordingly.

The system-clock frequency can be rescaled from 16MHz down to 1MHz for the MC68328 by programming the system-clock divider bits in the PLL control register (\$FFF200). For the MC68EZ328, the system-clock frequency can be scaled down to 512KHz by programming the prescaler and divider bits.

Because most of the modules, such as the UART, SPI, TIMER, and PWM, use the system clock for bit rate generation, changing the system-clock frequency will also change the system timing. Therefore, once a system-clock frequency is selected, it should not be changed during system operation. Burst and DOZE modes are then used for power saving.

Burst Mode

If the user wants to keep the modules enabled at a high system-clock frequency during normal operation without requiring maximum CPU performance, burst CPU clock-control mode can be enabled. The period of a burst is 1 ms, and the duty-cycle of a burst is controlled by the value of the WIDTH bits in the power control register. The user can choose from 1/31 to 31/31 of 1 ms of CPU active time for every 1 ms burst period. A WIDTH value of zero will place the CPU in DOZE mode. Smaller values of WIDTH will reduce system power consumption.

Burst mode is often used in data-polling applications. Burst mode is entered by setting the PC EN bit and program the WIDTH bits of the power control register. Burst mode is disabled automatically when there is an interrupt event. Clearing the PC EN bit will also disable burst control.

DOZE Mode

For many PDA applications, the system takes only a little time to process tasks the user requests, after which the system waits again for user commands, such as a touch screen input. During the waiting period, some peripherals like the LCD screen must be active. Therefore, the developer can stop the CPU in these waiting periods using DOZE mode.

As mentioned before, DOZE mode is entered by setting the PC EN bit and clearing the WIDTH bits of the power control register. DOZE mode is disabled automatically when there is an interrupt event.

Sleep Mode

In sleep mode the CPU and all peripherals but the RTC are in an inactive state. Sleep mode is entered by disabling PLL, thus stopping the system clock. Only the external 32KHz clock still inputs to the RTC module. Because 32KHz is a low-frequency signal, the RTC consumes less than 1 uA.

When disabling the PLL to enter sleep mode, please follow the PLL shut-down sequence specified in the DragonBall user's manual. Sleep mode is disabled automatically when there is an interrupt event. Note that upon wake-up it takes 1 ms for the PLL to stabilize and provide a system clock

Power Consumption Test

Both the MC68328 and MC68EZ328 user's manuals state that the maximum current consumption at 3.3V is 20 mA for normal mode and 20uA for sleep mode. The user should remember that "system up" does not always mean "full running." Burst or DOZE mode can be used. In burst/DOZE mode, current consumption is substantially less than 20mA. Power tests with the MC68328 and MC68EZ328 show that they both consume similar amounts of current in the same configuration. Refer to the following sections for benchmark data.

Test Hardware Set-Up

Figure 3 shows the hardware set-up for this power measurement.

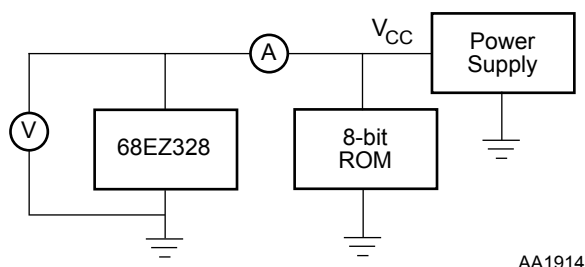
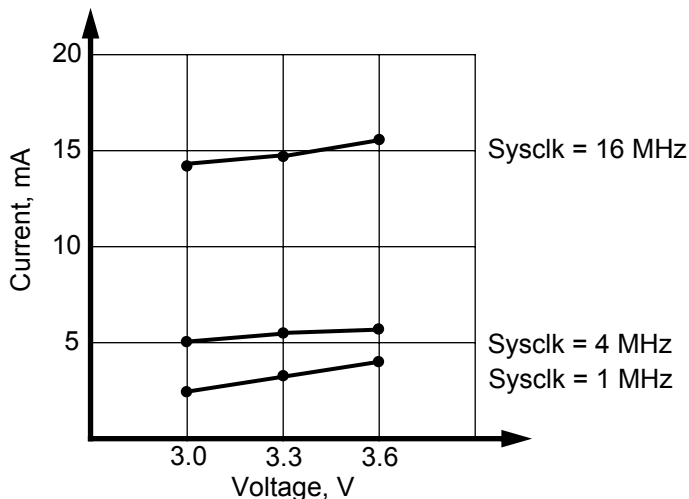

Figure 3. Hardware Configuration for Power Consumption Test

Normal Mode Test

Figure 4 graphs the following test condition: the CPU is continuously running; the LCD controller is enabled and initialized to 240x160 b/w; the RTC is enabled; and the ROM chip-select is configured for 1 wait state.



AA1915

Figure 4. Normal Mode Test

Burst Mode Test

Figure 5 diagrams the following test condition: a burst-duty cycle value of 1/31 clock is applied to the CPU clock; the LCD is enabled and is initialized to 240x160 b/w; the RTC is enabled; and the ROM chip select is configured for 1 wait state.

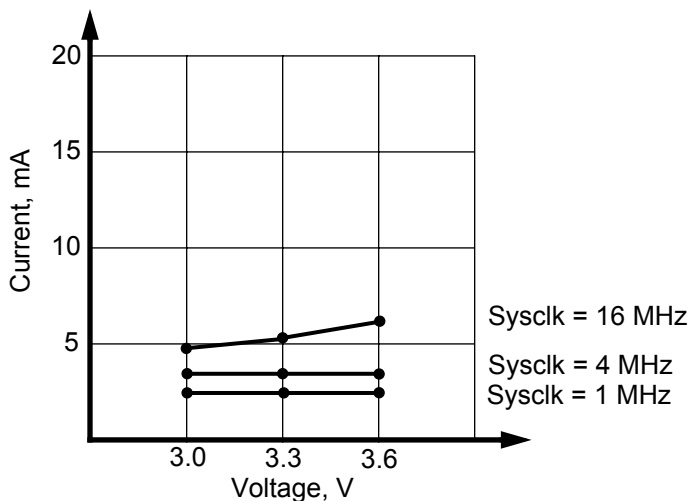

AA1916

Figure 5. Burst Mode Test

DOZE Mode Test

Refer to Figure 6 for a diagram of the following test condition: the CPU clock is stopped (0/31 burst-duty cycle); the LCD is enabled and is initialized to 240x160 b/w; the RTC is enabled; and the ROM chip select is configured for 1 wait state.

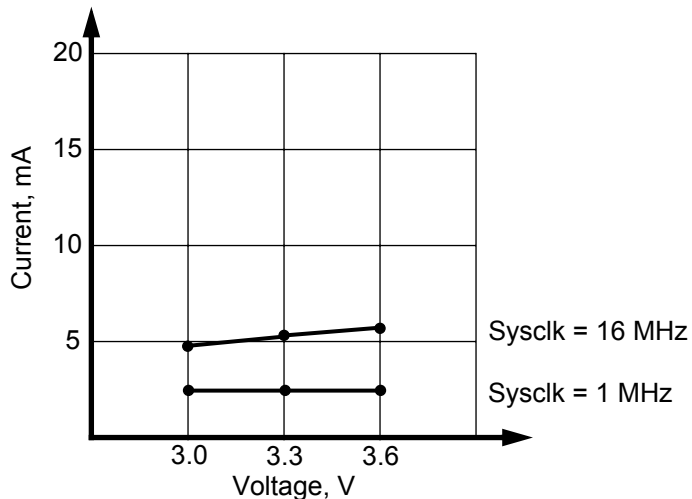

AA1917

Figure 6. DOZE Mode Test

Sleep Mode Test

Figure 7 graphs the following test condition: the PLL is turned off and only the RTC is enabled.

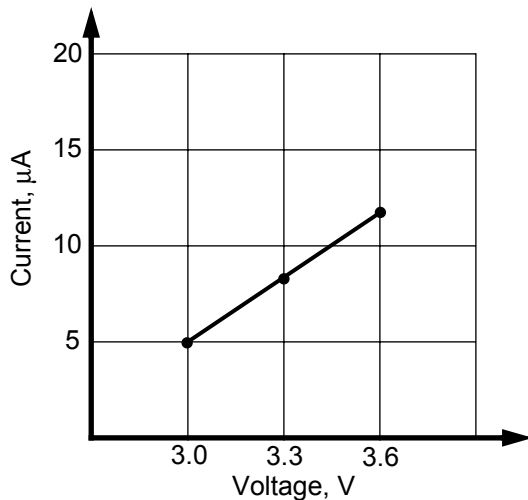

AA1918

Figure 7. Sleep Mode Test

Conclusions

The most effective power-control strategy is to run the CPU at its highest system speed until no CPU cycles are needed and then to enter DOZE mode. Other power-saving system-design techniques include the use of interrupts, instead of data polling, and configuring unused I/O pins to be inputs. It is important not to enable internal pull-up resistors unless it is necessary. (Internal pull-up resistors are 100K ohms.) Finally, the user should disable external devices before entering sleep mode. Use of the modes and techniques listed in this application note should result in an optimally low system power dissipation for the DragonBall processors.

How to Reach Us:

Home Page:
www.freescale.com

E-mail:
support@freescale.com

USA/Europe or Locations Not Listed:
Freescale Semiconductor
Technical Information Center, CH370
1300 N. Alma School Road
Chandler, Arizona 85224
+1-800-521-6274 or +1-480-768-2130
support@freescale.com

Europe, Middle East, and Africa:
Freescale Halbleiter Deutschland GmbH
Technical Information Center
Schatzbogen 7
81829 Muenchen, Germany
+44 1296 380 456 (English)
+46 8 52200080 (English)
+49 89 92103 559 (German)
+33 1 69 35 48 48 (French)
support@freescale.com

Japan:
Freescale Semiconductor Japan Ltd.
Headquarters
ARCO Tower 15F
1-8-1, Shimo-Meguro, Meguro-ku,
Tokyo 153-0064
Japan
0120 191014 or +81 3 5437 9125
support.japan@freescale.com

Asia/Pacific:
Freescale Semiconductor Hong Kong Ltd.
Technical Information Center
2 Dai King Street
Tai Po Industrial Estate
Tai Po, N.T., Hong Kong
+800 2666 8080
support.asia@freescale.com

For Literature Requests Only:
Freescale Semiconductor Literature Distribution Center
P.O. Box 5405
Denver, Colorado 80217
1-800-441-2447 or 303-675-2140
Fax: 303-675-2150
LDCForFreescaleSemiconductor@hibbertgroup.com

Information in this document is provided solely to enable system and software implementers to use Freescale Semiconductor products. There are no express or implied copyright licenses granted hereunder to design or fabricate any integrated circuits or integrated circuits based on the information in this document. Freescale Semiconductor reserves the right to make changes without further notice to any products herein. Freescale Semiconductor makes no warranty, representation or guarantee regarding the suitability of its products for any particular purpose, nor does Freescale Semiconductor assume any liability arising out of the application or use of any product or circuit, and specifically disclaims any and all liability, including without limitation consequential or incidental damages. "Typical" parameters which may be provided in Freescale Semiconductor data sheets and/or specifications can and do vary in different applications and actual performance may vary over time. All operating parameters, including "Typicals" must be validated for each customer application by customer's technical experts. Freescale Semiconductor does not convey any license under its patent rights nor the rights of others. Freescale Semiconductor products are not designed, intended, or authorized for use as components in systems intended for surgical implant into the body, or other applications intended to support or sustain life, or for any other application in which the failure of the Freescale Semiconductor product could create a situation where personal injury or death may occur. Should Buyer purchase or use Freescale Semiconductor products for any such unintended or unauthorized application, Buyer shall indemnify and hold Freescale Semiconductor and its officers, employees, subsidiaries, affiliates, and distributors harmless against all claims, costs, damages, and expenses, and reasonable attorney fees arising out of, directly or indirectly, any claim of personal injury or death associated with such unintended or unauthorized use, even if such claim alleges that Freescale Semiconductor was negligent regarding the design or manufacture of the part.

