

Application Note

AN2611
Rev. 0, 11/2003

*System Considerations for
Short Range RF Devices*

By **Laurent GAUTHIER**
Access and Remote Control
Toulouse, France

Introduction

This application note presents some considerations concerning Short Range Devices (SRD) at a system level. These allow sizing a system for a given level of performance.

System Overview

A system using an RF link should be designed by keeping in mind the level of performance it should meet. Range is affected by the power of the transmitter, the sensitivity of the receiver, the efficiency of the antennas at both sides and the nature of the field itself.

Before beginning any design, some basic calculations can be done to evaluate if the required performances are possible with the available components. Once every system parameter is validated, it is then possible to begin the design of the electronic parts. If the calculation shows some limits, it is not realistic to imagine that the system will work.

Due to the complex nature of the propagation in a real field, some final field measurements should validate the system. A reasonable margin taken during the design will improve the reliability of the RF link.

System Description

From a system point of view, an SRD application¹ can be seen as:

- the transmitter delivers a power P_{Txout} to the Tx antenna
- the Tx antenna radiates a power P_{TxRad}
- the propagation field attenuates the radiated power
- the Rx antenna receives a power P_{RxRad}
- the receiver receives a power P_{Rxin}

The parameters² of the system are:

- System
 - F: frequency of operation expressed in MHz
- Transmitter:
 - P_{txout} : the output power expressed in dBm³
 - G_{TxAnt} : the gain of the antenna expressed in dB⁴
- Propagation field:
 - D: distance between the Tx antenna and the Rx antenna expressed in metres
 - G_{Field} : path attenuation, a function of D, F and the field itself
- Receiver:
 - G_{rxAnt} : the gain of the antenna expressed in dB
 - $RxSens$: the minimum signal power the receiver can process

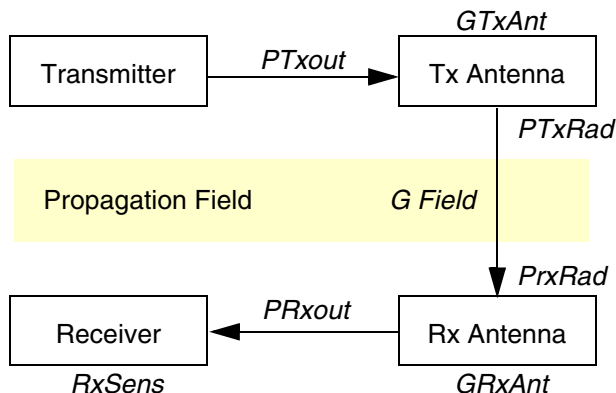

1. SRD applications include remote control and data communications.
 2. All the “gain” and “attenuation” parameters have the same meaning: a positive value means some gain, and a negative value means some attenuation, whatever the parameter is called “Gain”, “Attenuation”, “Margin” or “Loss”.
 3. The dBm is a logarithmic power unit relative to a milliwatt: $PdBm = 10 \cdot \text{Log}(P)$, with P expressed in mW.
 4. A gain expressed in dB (A dB) can be calculated with the scalar gain (A): $A \text{ dB} = 10 \cdot \text{Log}(A)$

Field Attenuation

The field attenuation increases with the distance D and the frequency F. It also depends on the field itself. Some objects around the line of RF transmission can have great influence, because they can reflect the signal, and the receiver will see the sum of the direct wave and many reflected ones. Because the phase of the various signals will vary, if those objects or the transmitter or the receiver will move, this fading can lead to non reliable transmission.

All the computations we will see are based on a “Far Field” approximation¹ and the model is valid for most applications.

With F in MHz and D in metres:

$$G_{Field} = 27.6 - 20 \times \log(F) - n \times \log(D)$$

n is the Path Loss Factor that depends on the field itself, and takes into account different scenarios of multi-path transmission.

Field	n	Comment
Free space	20	applies to open-view line-of-sight propagation
Open field	25	Tx and Rx 1.5 m above the ground, in a large open space
Open office	30	indoor open office and retail space
Dense office	40	dense cubical office space

Additional Path Loss

To the above attenuation should be added an additional loss that will depend on the object causing the path loss:

Object	Gadd	Comments
Wall (indoor)	-10 to -15 dB	
Wall (exterior)	0 to -40 dB	decreases as number of windows increases
Floor	-10 to -30 dB	
Window	0 to -30 dB	metal tinted windows cause high loss

1. The “Far Field” approximation supposes that the receiver is at least at a distance $D > 10 \cdot \lambda$, with $\lambda = c/F$ ($c = 3 \cdot 10^8$ m/s).

Margin and Link Reliability

The range is computed as a limit. That means you need some margins that will depend on the reliability of the RF link you want. In fact, the common way to increase the reliability of a system is to increase the signal level at the receiver side.

Applications	Link reliability	Margin
Car locking, Toys	<50%	0 dB
Door chimes	>90%	-10 dB
Monitoring systems	>99%	-20 dB
Professional telemetry	>99.9%	-30 dB
Critical radio link	>99.99%	-40 dB

Range Computation

The different power levels and parameters of the system, when expressed in dB units (dBm), are linked as follows.

$$PTxRad = PTxout + GTxAnt$$

$$PRxRad = PTxRad + GField + Gadd + Mar$$

$$PRxin = PRxRad + GRxAnt$$

The range of the system is the distance D that implies a received signal power equal to the sensitivity of the receiver, plus the margin defined. So:

$$PRxin = RxSens$$

and

$$RxSens = GRxant + GTxAnt + 27.6 - 20 \times \log(F) - n \times \log(D) + Gadd + Mar + PTxout$$

Then:

$$Range = 10^{\frac{PTxout + GTxAnt + GRxAnt - RxSens + 27.6 - 20 \times \log(F) + Gadd + Mar}{n}}$$

Radiated Power Limits

Regulations of each country limit the power radiated for RF applications. This limits, most of the time, the performance of the system (when the receiver is optimized).

For SRD applications, the limits are given in the following table.¹

Frequency	PTxRad	RF Field @3m	Country	Regulation
916.5 MHz	-13.3 dBm	82 dB μ V/m	USA	FCC 15.231.A-D
	-21.3 dBm	74 dB μ V/m	USA	FCC 15.231.E
868.3 MHz	+14dBm	109 dB μ V/m	Europe	EN 300 220
433.92 MHz	+10 dBm	105 dB μ V/m	Europe	EN 300 220
	-14.4 dBm	81 dB μ V/m	USA	FCC 15.231.A-D
	-22.5 dBm	73 dB μ V/m	USA	FCC 15.231.E
418 MHz	-6 dBm	89 dB μ V/m	UK	(out of date regulation)
<322 MHz	-41.3 dBm	54 dB μ V/m	Japan	Bijaku
>322 MHz	-64.4 dBm	31 dB μ V/m	Japan	Bijaku
315 MHz	-19.6 dBm	76 dB μ V/m	USA	FCC 15.231.A-D
	-27.5 dBm	68 dB μ V/m	USA	FCC 15.231.E

Some care should be taken when comparing those numbers. For example, in Europe, radiated power is expressed as peak power, and in the USA it is expressed as average power. Some examples of computation for peak and average power are given in the following sections.

System Performance Examples

An Excel sheet is available online² to help system evaluation. It computes the range and the field levels, given all the parameters of the system.

433.92 MHz ETSI Compliant System

ETSI regulations limit the transmitted power to 10 mW or 10 dBm in the 434 MHz band. Some margin should be taken to not exceed this limit over production dispersion, a few dB is enough.

Because it is easier to compare the performance of systems outdoors, we will define a remote control to have the maximum range with a given technology.

- Application:
 - frequency: 433.92MHz
 - European application: PTxRad = + 10 dBm max
 - not a critical remote control: Mar = 0 dB
- The transmitter is a small remote control:
 - an integrated PLL delivering to an amplifier: P_{Ic}out = 2 dBm
 - an amplifier delivering to the antenna: P_Txout = 11 dBm

1. Freescale provides this general information on the various regulations without guarantee of accuracy or completeness. Please consult each country for the latest information.
2. <http://e-www.freescale.com/webapp/sps/site/taxonomy.jsp?nodeId=01M0ymXyR46>.

- a shortened $\lambda/4$ antenna: $G_{TxAnt} = -5$ dB
- The receiver is defined by:
 - a shortened $\lambda/4$ antenna: $G_{RxAnt} = -5$ dB
 - a receiver composed of:
 - a low noise amplifier
 - a saw filter
 - an integrated receiver
 - overall sensitivity: $RxSens > -105$ dBm
- The propagation Field:
 - the field is open: $n = 25$
 - free line of sight: $G_{add} = 0$ dB

With this definition, the system is compliant with ETSI regulations, because the radiated power is:

$$P_{TxRad} = P_{Txout} + G_{TxAnt} = 11 - 5 = 6 \text{ dBm}$$

We can use the Excel file AN2611XLS to do the range computation.

Frequency	<i>F</i>	433.92	MHz
Tx Output power	<i>Ptxout</i>	11	dBm
Tx Antenna gain	<i>GTxAnt</i>	-5	dB
Rx Antenna gain	<i>GRxAnt</i>	-5	dB
RX sensitivity	<i>RxSens</i>	-105	dBm
Additional losses	<i>Gadd</i>	0	dB
Margin	<i>Mar</i>	0	dB
Path Loss Factor	<i>n</i>	25	
<input type="button" value="Open field"/> <input type="button" value="Car locking, Toys"/>			
Radiated power	<i>PTxRad</i>	6.00dBm	
		3,981.072μW	
Measuring distance	<i>d</i>	3.00m	
Free space field Level	<i>VField</i>	101.26dBμV/m	
		115,578.95μV/m	
	<i>HField</i>	49.73dBμA/m	
		306.58μA/m	
Field Level at RX	<i>PrxRad</i>	29.75dBμV/m	
		30.72μV/m	
Range	<i>D</i>	1,714.24m	
		5,624ft	

The range is then 1714 m.

**315 MHz FCC
Compliant System**

The FCC regulation limits the transmitted power to -19.6 dBm in the 315 MHz band. This power is measured using a CISPR quasi-peak detector that is equivalent to an average filter.

The duty cycle of the transmission depends on the modulation used. For OOK (On/Off Keying), the transmission is cut during low levels, but for FSK (Frequency Shift Keying), the transmission is at constant power.

Then, for an OOK Manchester coding modulated frame, with no pause between successive frames, the duty cycle is 50%; and for an FSK Manchester coding modulated frame, the duty cycle is 100%.

The average factor gives an improvement of: $AF(dB) = -10 \times \log(DC)$

This gives 3 dB in OOK and 0 dB in FSK.

The maximum allowed radiated peak power is -19.6 dBm in FSK and -16.6 dBm in OOK.

Some margin should be allowed to make sure this limit is not exceeded, over production dispersion; a few dB is enough.

Because it is easier to compare the performance of systems outdoors, we will define a remote control to have the maximum range with a given technology.

- Application:
 - Frequency: 315 MHz
 - USA application: $P_{TxRad} = -19.6$ dBm max
 - Not a critical remote control: $Mar = 0$ dB
- The transmitter is a small remote control:
 - An integrated PLL delivering to the antenna: $P_{Txout} = +5$ dBm
 - A small loop antenna: $G_{TxAnt} = -30$ dB
- The receiver is defined by:
 - A shorten $\lambda/4$ antenna: $G_{RxAnt} = -5$ dB
 - A receiver composed of:
 - An integrated receiver: $RxSens < -105$ dBm
- The propagation Field:
 - The field is open: $n = 25$
 - Free line of sight: $G_{add} = 0$ dB

With this definition, the system is compliant with FCC regulation because the radiated power is:

$$P_{TxRad} = P_{Txout} + G_{TxAnt} = 5 - 30 = -25 \text{ dBm}$$

We can use the Excel file RANGE.XLS to do the range computation.

Frequency	<i>F</i>	315	MHz
Tx Output power	<i>Ptxout</i>	5	dBm
Tx Antenna gain	<i>GTxAnt</i>	-30	dB
Rx Antenna gain	<i>GRxAnt</i>	-5	dB
RX sensitivity	<i>RxSens</i>	-105	dBm
Additional losses	<i>Gadd</i>	0	dB
Margin	<i>Mar</i>	0	dB
Path Loss Factor	<i>n</i>	25	
		<input type="button" value="Open field"/>	<input type="button" value="Car locking, Toys"/>
Radiated power	<i>PTxRad</i>	-25.00dBm	3.162μW
Measuring distance	<i>d</i>	3.00m	
Free space field Level	<i>VField</i>	70.26dBμV/m	3,257.46μV/m
	<i>HField</i>	18.73dBμA/m	8.64μA/m
Field Level at RX	<i>PRxRad</i>	26.97dBμV/m	22.30μV/m
Range	<i>D</i>	127.45m	418ft

The range is then 127m.

How to Reach Us:

Home Page:

www.freescale.com

E-mail:

support@freescale.com

USA/Europe or Locations Not Listed:

Freescale Semiconductor
 Technical Information Center, CH370
 1300 N. Alma School Road
 Chandler, Arizona 85224
 +1-800-521-6274 or +1-480-768-2130
support@freescale.com

Europe, Middle East, and Africa:

Freescale Halbleiter Deutschland GmbH
 Technical Information Center
 Schatzbogen 7
 81829 Muenchen, Germany
 +44 1296 380 456 (English)
 +46 8 52200080 (English)
 +49 89 92103 559 (German)
 +33 1 69 35 48 48 (French)
support@freescale.com

Japan:

Freescale Semiconductor Japan Ltd.
 Headquarters
 ARCO Tower 15F
 1-8-1, Shimo-Meguro, Meguro-ku,
 Tokyo 153-0064
 Japan
 0120 191014 or +81 3 5437 9125
support.japan@freescale.com

Asia/Pacific:

Freescale Semiconductor Hong Kong Ltd.
 Technical Information Center
 2 Dai King Street
 Tai Po Industrial Estate
 Tai Po, N.T., Hong Kong
 +800 2666 8080
support.asia@freescale.com

For Literature Requests Only:

Freescale Semiconductor Literature Distribution Center
 P.O. Box 5405
 Denver, Colorado 80217
 1-800-441-2447 or 303-675-2140
 Fax: 303-675-2150
LDCForFreescaleSemiconductor@hibbertgroup.com

Information in this document is provided solely to enable system and software implementers to use Freescale Semiconductor products. There are no express or implied copyright licenses granted hereunder to design or fabricate any integrated circuits or integrated circuits based on the information in this document.

Freescale Semiconductor reserves the right to make changes without further notice to any products herein. Freescale Semiconductor makes no warranty, representation or guarantee regarding the suitability of its products for any particular purpose, nor does Freescale Semiconductor assume any liability arising out of the application or use of any product or circuit, and specifically disclaims any and all liability, including without limitation consequential or incidental damages. "Typical" parameters which may be provided in Freescale Semiconductor data sheets and/or specifications can and do vary in different applications and actual performance may vary over time. All operating parameters, including "Typicals" must be validated for each customer application by customer's technical experts. Freescale Semiconductor does not convey any license under its patent rights nor the rights of others. Freescale Semiconductor products are not designed, intended, or authorized for use as components in systems intended for surgical implant into the body, or other applications intended to support or sustain life, or for any other application in which the failure of the Freescale Semiconductor product could create a situation where personal injury or death may occur. Should Buyer purchase or use Freescale Semiconductor products for any such unintended or unauthorized application, Buyer shall indemnify and hold Freescale Semiconductor and its officers, employees, subsidiaries, affiliates, and distributors harmless against all claims, costs, damages, and expenses, and reasonable attorney fees arising out of, directly or indirectly, any claim of personal injury or death associated with such unintended or unauthorized use, even if such claim alleges that Freescale Semiconductor was negligent regarding the design or manufacture of the part.

