

g-Sensor High-Brightness LED Brake Lamp

by: Matt Ruff and Wolfgang Bihlmayr
Automotive Systems Engineering
Austin, Texas and Munich, Germany

The g-sensor high brightness LED brake lamp application is designed with motorcyclist safety in mind. Although the principles transfer to any vehicle, they are especially valuable to drivers on two wheels.

Motorcyclists are hard to see in traffic, and most accelerate and decelerate faster than cars. These combined factors increase the chances for motorcyclist injury and fatality.

The g-sensor brake lamp provides high-intensity variable light output proportional to a vehicle's deceleration, providing valuable information to drivers behind motorcycles. The brake lamp uses the MMA7260Q three axis, low-g accelerometer and the highly integrated Freescale MM908E625 system in a package device containing an HC908EY16 microcontroller and fully self-protecting and intelligent analog circuitry. The HC908EY16 reads three axes of acceleration and deceleration data from the accelerometer, controls the system, and drives eight high-brightness LEDs.

Contents

1	Basic System Description	2
1.1	Key System Features	2
1.2	System Block Diagram	2
1.3	Basic System Behavior	4
2	Accelerometers: The Key to the System	5
2.1	Measuring Deceleration with the MMA7260Q	5
2.2	Collecting Acceleration/Deceleration Data	6
2.3	Managing Vibration and Noise	8
3	Driving the High Brightness LEDs	10
3.1	Basic HBLED Drive Channels with MM908E625 Half-Bridges	10
3.2	Additional LED Control Circuitry	12
4	Additional System Features	12
5	Software Design	13
5.1	Software State Machine	13
5.2	Accelerometer Initialization and Calibration	14
6	Looking Forward	15
7	References	16
8	Schematics	17
8.1	Bill of Materials	18

1 Basic System Description

1.1 Key System Features

The g-sensor brake lamp is a brake lamp with light output proportional to the vehicle’s deceleration. The brake lamp has many functions beyond a proportional brake light:

- High brightness LED output with eight, one-watt high-brightness LEDs (approximately 350 lumen maximum light output)
- Four brake-intensity warning levels based on deceleration
- Redundant backup for standard brake lamp for added safety
- Self-calibration-capable — Automatically senses physical mounting orientation and re-calibrates
- Photo-sensor that compensates for brightness output in daylight or night-light
- Flashing turn signal duplication
- White LED outputs illuminate license plate
- LIN network communications

1.2 System Block Diagram

Figure 1 shows a block diagram of the g-sensor brake-lamp design. Internal components of the MM908E625 device are shown separately for clarification but are contained in a single package. This package contains the MCU and analog circuitry to drive the high-brightness LEDs, monitor the g-sensor output, the brake, left turn, and right turn signal lamps, as well as communicate over the LIN network.

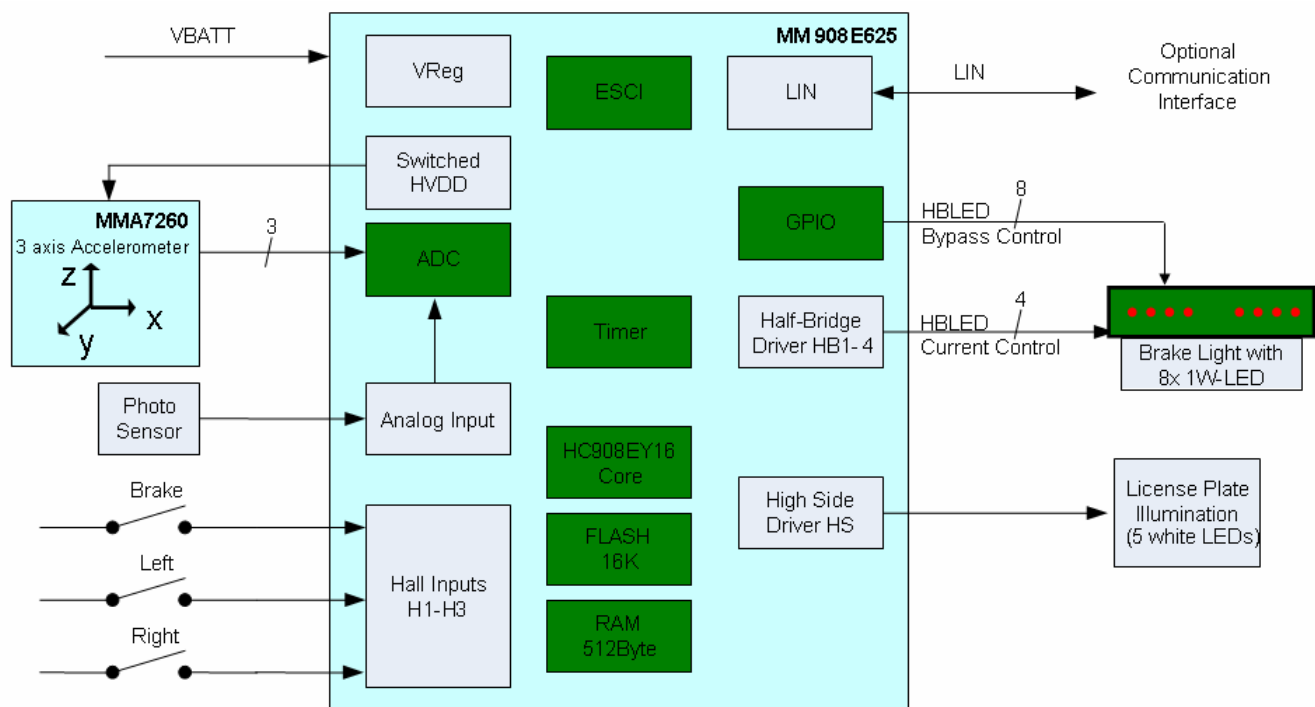

Figure 1. Block Diagram of g-Sensor Brake Lamp

Figure 2 shows both sides of the circuit board. The board layout allows for spacing of the HBLEDs for heat dissipation and for visual separation when mounted to a vehicle. The LEDs are mounted on one side of the board designed to mount into a bezel with holes cut for the LEDs. All other components are mounted to the other side of the board.

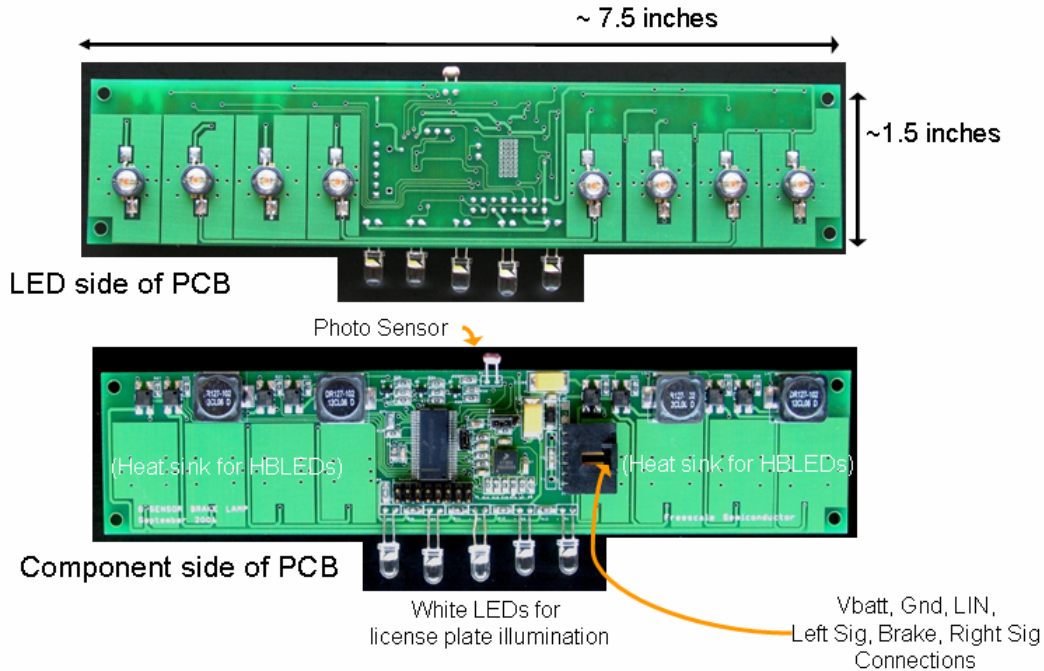

Figure 2. g-Sensor Brake Lamp Hardware — Front and Back of PCB (Revision 2)

Basic design components:

- The MCU reads the information from the accelerometer, interprets it, decides what the required LED output should be, and communicates this to the analog half-bridge outputs and timer channels to display.
- The accelerometer measures the acceleration of the assembly in all three axes. This allows the unit to be self-calibrating by measuring the force of gravity when the unit is at rest.
- The half-bridge-drive circuits in the analog portion of the MM908E625 device are used to provide current for the HBLEDs.
- A photo sensor measures ambient light levels and provides a variable resistance the MCU uses to determine the light level in the environment and adjusts the HBLEDs' brightness. In this way, the light output of the HBLEDs reduces at night and increases during the day to maximize visibility.

Figure 3 shows the component layout with an earlier revision of hardware.

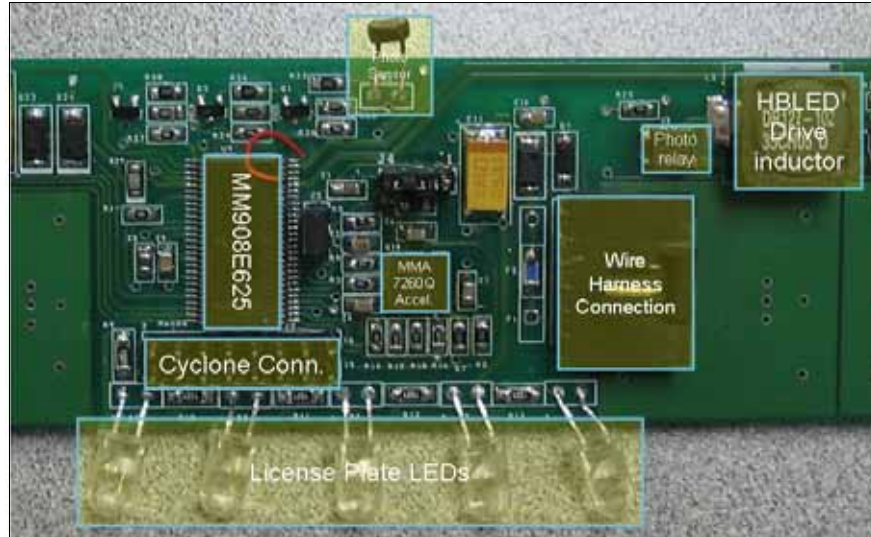

Figure 3. Layout of g-Sensor Brake Lamp Components

1.3 Basic System Behavior

The g-sensor brake lamp provides a variable brake lamp output based on deceleration. [Figure 4](#) and [Figure 5](#) show normal- and maximum-effort braking scenarios. [Figure 4](#) shows the brake lamp in action, with speed and deceleration shown on gauges. Maximum-effort braking occurs because a car pulled out in front of the rider. Notice the deceleration is much greater, as indicated by the gauge and the unloading of the bike’s rear suspension. The g-sensor brake lamp (below the standard brake light) responds by lighting more LEDs.



Figure 4. g-Sensor Brake Lamp Output-Simulation Comparison

[Figure 5](#) shows the actual g-sensor brake lamp prototype hardware on a test track. The g-sensor brake lamp is mounted to the motorcycle’s top luggage case, above the standard brake lamp. In the normal braking picture, four LEDs are illuminated. In the maximum effort braking picture, all eight LEDs are illuminated, indicating a much higher level of deceleration.



Figure 5. g-Sensor Brake Lamp Output Comparison

2 Accelerometers: The Key to the System

2.1 Measuring Deceleration with the MMA7260Q

The heart of the system is the MMA7260Q 3-axis accelerometer. It measures positive and negative acceleration in the X, Y, and Z axes, providing an analog voltage output for each axis. The accelerometer sensitivity can be adjusted for a maximum scale reading of 1.5, 2, 4, or 6 times the force of gravity.

Figure 6 shows the relationship of the acceleration/deceleration observed by the sensor to the value read from a 10-bit analog-to-digital converter measuring the sensor output for that axis. Although the relationship between acceleration/deceleration and output voltage is linear, it naturally falls to the midpoint voltage when the unit is at rest because the sensor measures acceleration in both directions along the axis of interest.

For the mounting orientation of the g-sensor brake lamp, increasing deceleration results in decreasing output voltage. With the board mounted exactly vertically, this force appears entirely in the Z axis. Therefore, the harder you brake, the lower the output voltage on the Z axis output and the lower the ADC result value.

The diagram also shows that even though the ADC reference voltage is set to 5 V, the operating voltage of the MMA7260Q is only 3 V. This results in the maximum 10-bit ADC reading of around 614 (rather than 1024). The reference voltage for the ADC must remain at 5 V to monitor parameters in the analog portion of the MM908E625, which reduces system sensitivity.

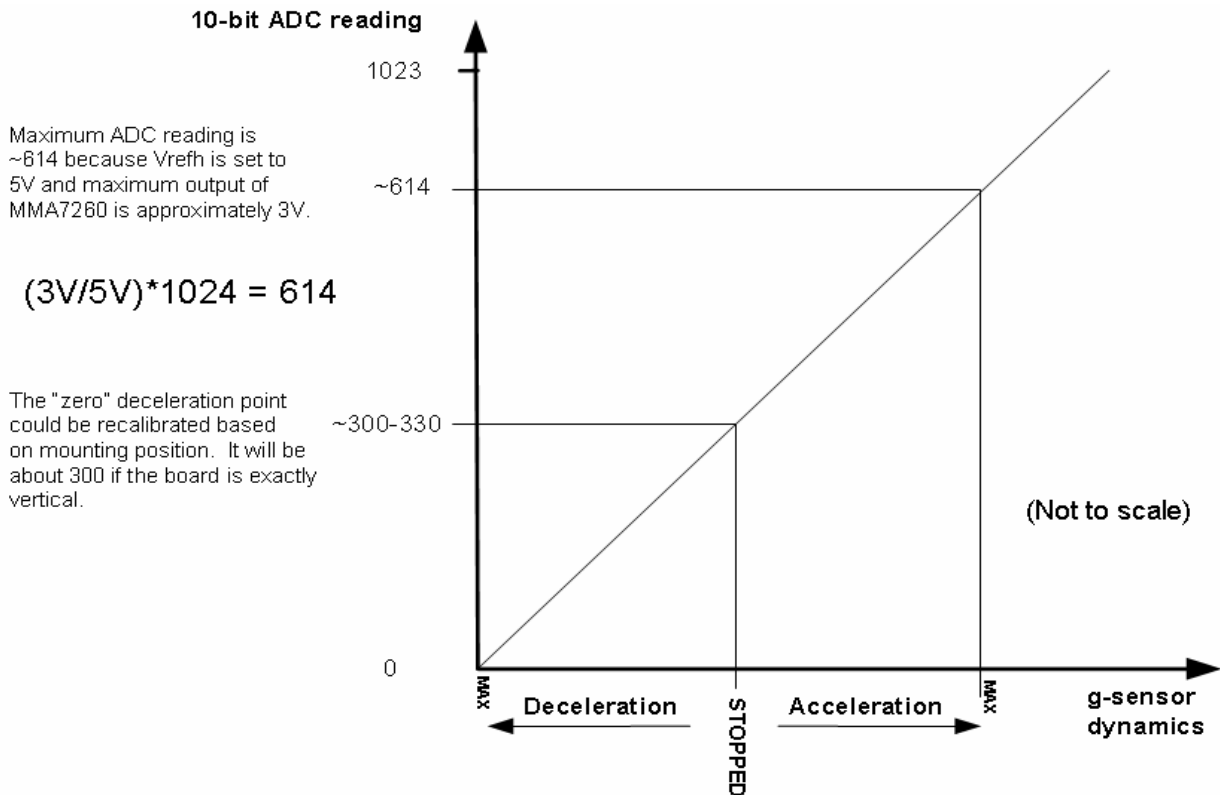

Figure 6. Translation of Deceleration and Acceleration into ADC Readings

In the g-sensor brake lamp application, deceleration is the only data of interest. Any ADC reading above the stopped reading of around 300 to 330 is ignored (presuming board is mounted vertically).

2.2 Collecting Acceleration/Deceleration Data

During testing, the ZSTAR wireless sensing triple axis reference design was employed to collect deceleration-force data. The ZSTAR design combines the same MMA7260Q three axis accelerometer with a pair of Freescale's MC13191 2.4 GHz ISM band low-power transceivers. One transceiver is on a board with the accelerometer, and the other is on a board which uses Freescale's MC68HC908JW32 MCU to allow the transceiver to plug into a USB port. Therefore, sensor data can be transmitted wirelessly to a laptop from a small, portable, battery-powered board.

To ensure that maximum reasonable braking forces were measured, the sensor board was mounted to the rear of a motorcycle (approximately 400 pound curb weight — wet). The mounting was achieved by drilling holes into a plastic inspection-sticker plate, attaching the PCB to this plate with zip ties, and mounting the inspection sticker plate below the license plate. This approximates the final mounting of the brake lamp assembly except that the Z axis is inverted because the MMA7260Q is mounted facing the rear. [Figure 7](#) shows this mounting arrangement.

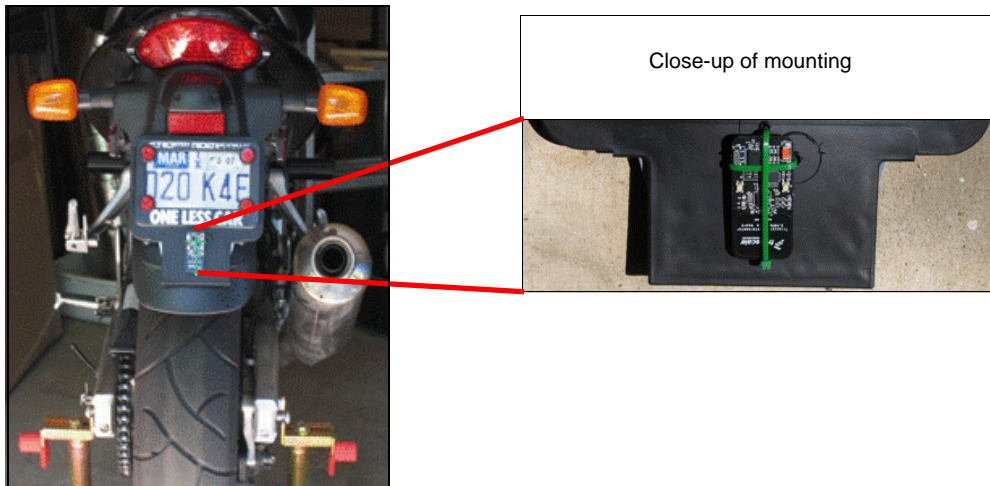

Figure 7. Z-Star g-Sensor Data Collection Mounting

The data was then collected while driving the motorcycle in a straight line to a specified speed then braking to a stop with various pressures. The goal was determining the brake-forces parameters.

Attempts were made to retrieve data while driving past a stationary laptop, but the distances required to reach initial speed (20 MPH to 40 MPH) and maintain distance from the data recorder proved too far for the transceivers. Finally, to maintain the wireless link, the laptop was strapped to the rear seat.

With a reliable connection, numerous data collection runs were performed at varying speeds and braking forces. [Figure 8](#) shows a graph of about 45 seconds of a typical data-collection run. The maximum deceleration during braking appears nearly full scale but does not seem to saturate. This indicates that the approximate maximum brake forces were 1.5 g (255 on an 8-bit scale with board mounted in this orientation). This allows for proper sensitivity adjustment of the MMA7260Q.

The vibrational noise also appears in the data with the acceleration/deceleration information. This is the largest design issue to overcome when determining the actual state of the vehicle at any time.

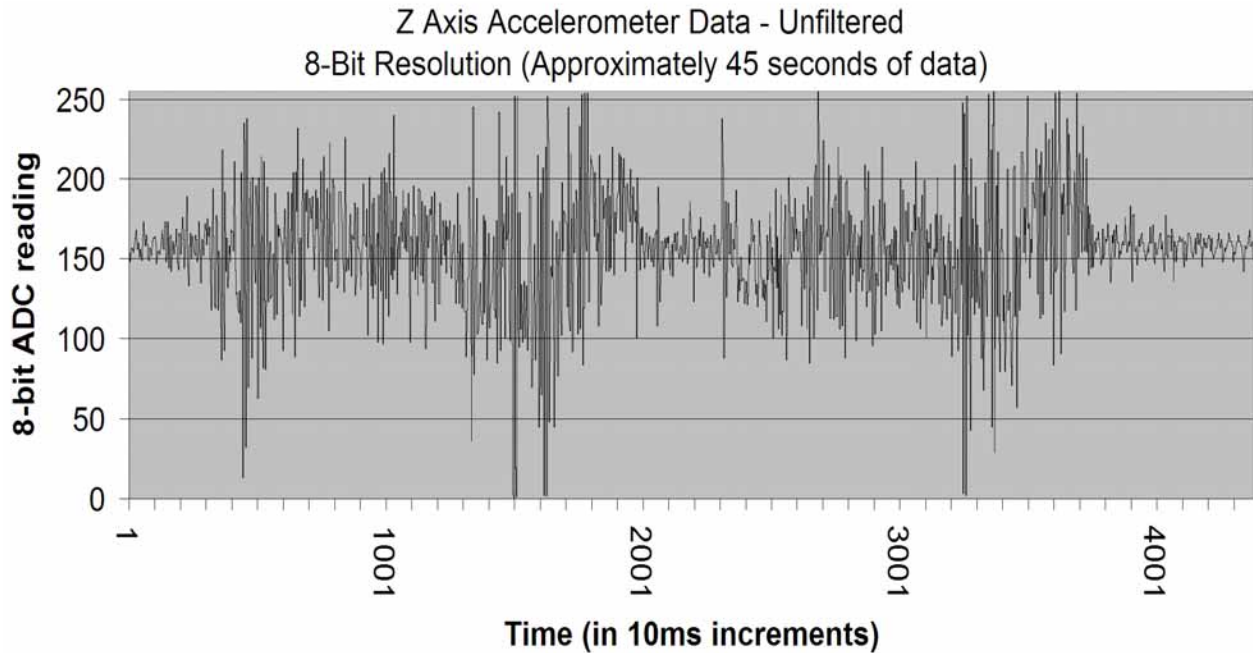

Figure 8. Raw 8-Bit Accelerometer Data

2.3 Managing Vibration and Noise

Vibration is a concern, particularly on a motorcycle, where the vehicle’s mass is relatively small and does not dampen the vibrations of the road and engine. The following section addresses the vibration issue and the resulting noise produced in the data.

2.3.1 Mechanical Considerations

The fundamental way to handle vibration is to isolate the sensor from the vibration mechanically. This is particularly difficult on a motorcycle. Mounting the lamp on the motorcycle’s luggage case was the best method of mechanical isolation (Figure 5). This deflected the suspension and the rider’s mass and, therefore, dampened road and engine vibration.

2.3.2 Analog Filtering

After all mechanical means of isolation are taken, the analog circuitry on the ADC inputs from the MMA7260Q can also be controlled to filter additional vibrational noise. Each sensor output has an RC filter that can be tuned to reduce higher frequency noise. Because the application is concerned only with relatively slow changes in the deceleration, ignore rapid changes (that is, high-frequency noise). Tuning the resistance or capacitance on these RC filters can reduce high-frequency noise. Consult the data sheets before selecting final values.

2.3.3 Software Filtering

After mechanical and electrical means of filtering are exhausted, the application has a third level of filtering. This filtering is done in the software and is comprised of three components:

- Digital low-pass filtering
- State machine state-processing delay
- Threshold hysteresis

The digital low-pass filter keeps a running average of the measured deceleration values. The sample rate and time constant for this filter are configurable, but the more noise filtered out, the slower the system response. [Figure 9](#) shows the code for the digital LP filter.

```
#define TIME_CONST 0.05           // Time constant for averaging deceleration values
#define SAMP_RATE 400           // Sample rate of system
#define DIVIDER      (TIME_CONST*SAMP_RATE)

...

UINT16 Current_Decel_Reading;    // Current deceleration reading
UINT16 Last_Decel_Reading;      // Previous deceleration reading
UINT16 Decel_Reading_Accum;     // Accumulated deceleration reading
UINT16 Decel_Value;            // New deceleration value
Last_Decel_Reading = *ADC_Value10(Z_AXIS_INPUT); // Initialize LP filter variable

...

For(;;)
{
    ...
    Current_Decel_Reading = *ADC_Value10(Z_AXIS_INPUT); // Update current reading
    Decel_Reading_Accum = Decel_Reading_Accum + (Current_Decel_Reading - Last_Decel_Reading);
    Decel_Value = Decel_Reading_Accum/((UINT16)DIVIDER); // Calculate new average
    Last_Decel_Reading = Decel_Value; // Update "last reading"
    ...
}
}
```

Figure 9. Code Example for Digital Low-Pass Filter

The configurable state machine processing delay is the second software technique for controlling the noise in sampling deceleration. This should not be confused with the actual sampling rate of the digital filter. Because the filter samples only one time per cycle through the main loop in this example code, the state machine processing delay can affect the sampling rate of the entire system. Therefore, the longer that loop takes to execute, the less frequently the MCU samples the deceleration rates. This can further control the sample rate of the low-pass filter, but in the code example shown, the state machine processing delay is minimized to smaller than the LP filter sample rate prevent this effect.

The final software method to control vibration and noise prevents oscillation between states when the deceleration value is close to the threshold between two states. Inserting hysteresis into the state transitions does not filter out noise in the data, but it does filter the output to the HBLEDs such that the brake lamp does not flicker noticeably when transitioning between two braking-level indications. [Figure 10](#) shows how this hysteresis works for state changes.

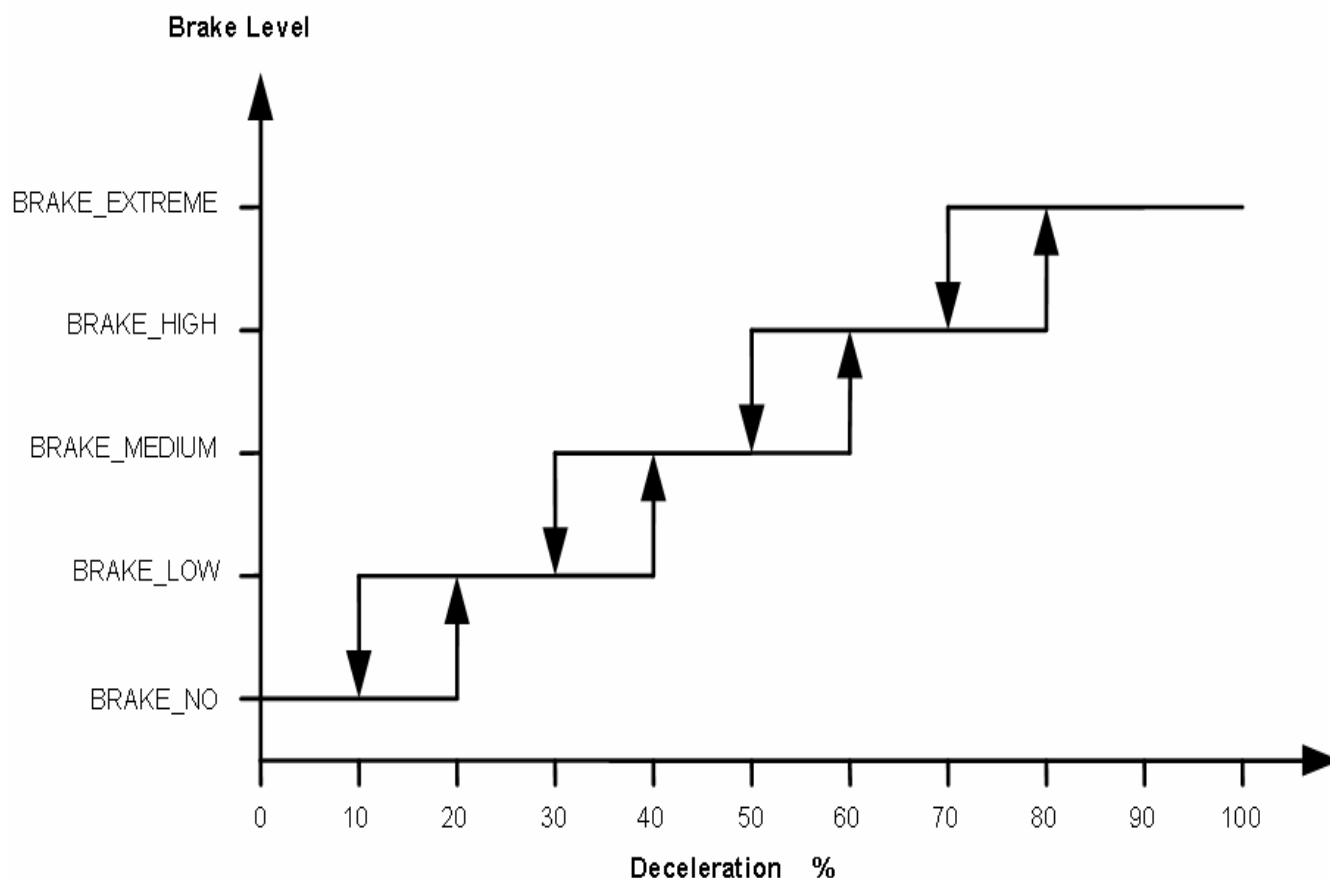

Figure 10. State Change Hysteresis

For example, when the deceleration reaches 20% of maximum, the state machine moves to level 1 (two HBLEDs lit). It remains in this state even if the deceleration drops a little due to noise. Deceleration must drop below 10% before the state machine allows the software to turn off the lights and return to level 0.

3 Driving the High Brightness LEDs

3.1 Basic HBLED Drive Channels with MM908E625 Half-Bridges

One advantage of using the MM908E625 device for this application is that the MCU is integrated with advanced, fully protected power circuitry. Included in this circuitry are four, half-bridge-power stages that can drive motors and higher current loads.

The low side of each half bridge, is used to drive a pair of HBLEDs and provide a constant current supply to the HBLEDs. These low-side switches have configurable current limits that automatically prevent overcurrent to the load and can be preset to 55 mA, 260 mA, 370 mA, 550 mA, or 740 mA (typical). This works well for this application, where the average load current should be around 350 mA. Additionally,

the low-side drivers of the half bridges provide a current recopy feature to allow the MCU to measure the actual current to the load through an ADC channel.

The only external component required to drive the HBLEDs is an inductor to manage load current ripple. [Figure 11](#) shows circuit layout. Selection of this inductor value is a function of the switching frequency of the switch, the operating voltage to the drive circuit, and the total forward voltage drop of the HBLEDs. The half-bridge output includes a freewheel diode to dissipate the voltage spike that results when the switch is turned off.

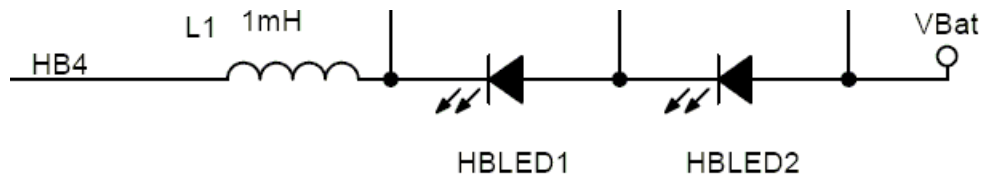

Figure 11. Basic High Brightness LED Drive Circuit Using MM908E625 Low-Side Switches

Because the low-side driver of the half bridge prevents overcurrent of the HBLEDs, control brightness by controlling the driver’s on time. [Figure 12](#) shows the cathode voltage of one drive channel of HBLEDs at three different brightness intensities. While the drive channel is on, the current limitation rapidly switches on and off, while the brightness switching occurs at a lower frequency. For specific frequencies, refer to the code for this application note. In this example, the brightness switching is around 200 Hz and the current limitation is switching about 20 kHz.

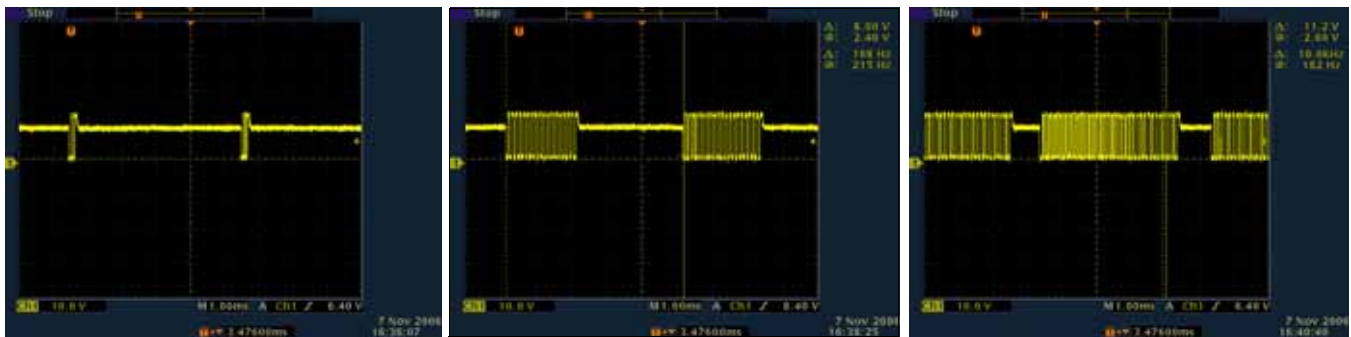

Figure 12. Voltage Measured at LED Cathode (Low, Medium, High Intensities Respectively)

Another benefit is the offset chopping feature that spreads the peak switching currents to reduce radiated emissions. If bit `OFC_EN` in the H-bridge control (`HBCTL`) register is set, HB1 and HB2 continue to switch on the low-side MOSFETs with the rising edge of the `FGEN` clock signal and HB3, and HB4 switch on the low-side MOSFETs with the falling edge on the `FGEN` clock input.

Details of how to use the MM908E625 half bridge outputs to regulate current in HBLEDs can be found in application note *AN3321 High-Brightness LED Control Interface*. This also describes other methods of controlling HBLEDs.

3.2 Additional LED Control Circuitry

Because the MM908E625 device has only four half-bridge outputs, it can only drive four channels of HBLEDs. This would be sufficient for the progressive brake-lamp output showing deceleration of the vehicle, where two HBLEDs could be ganged onto each drive channel and placed on either side of the center of the board. This would allow each LED drive channel to control a pair of HBLEDs centered around the center of the board. For added flexibility in the design, however, individual control of all eight HBLEDs was desired.

To control eight HBLEDs with only four drive channels, solid state optical relays were added in parallel to each HBLED to allow for bypassing the HBLED to switch either HBLED off while the drive channel is on. Figure 13 shows how these relays work. In this figure, when the relays are disabled, as in the left picture, both HBLEDs are lit. If only one of the HBLEDs is lit, the relay corresponding to the HBLED to be extinguished is activated. See the right diagram of Figure 13, where HBLED2 is bypassed and the current flows through the relay instead of HBLED2, only allowing HBLED1 to light.

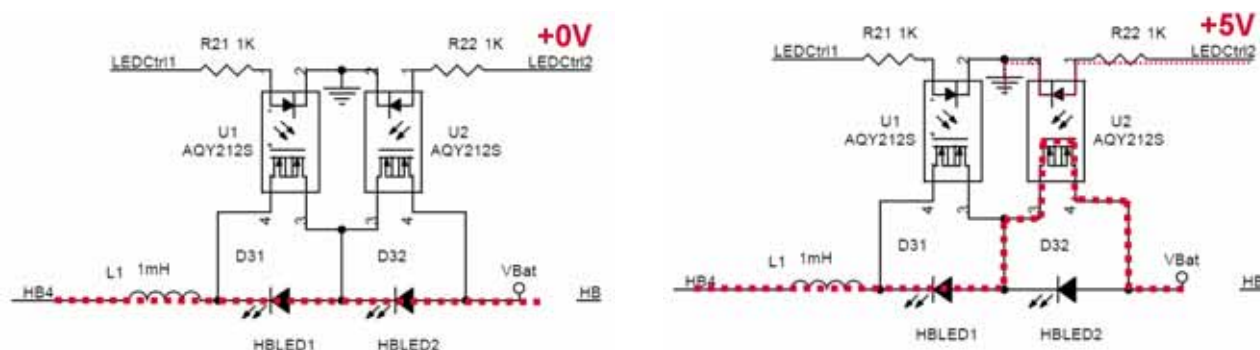

Figure 13. LED Drive and Control Circuitry — Photo Relays Disabled and Enabled

4 Additional System Features

- License plate illumination — The single high-side driver output (HS) on the MM908E625 is used to drive white LEDs designed to illuminate the vehicle license plate. The board design is such that it can be integrated into the top side of an aftermarket license plate frame and the white LEDs would shine down onto the plate.
- Daylight brightness compensation using photo sensor — A light-sensitive photo resistor is connected to the dedicated analog input terminal, which supplies its own selectable constant current source. This sensor measures ambient light levels so the brightness of the HBLEDs can be increased during daytime for better visibility and reduced during nighttime to prevent blinding other drivers.
- Monitoring of 12 V vehicle signaling — Design uses the MM908E625 hall-effect sensors to monitor the status of the vehicle brake lamps and the left and right signal indicator lamps. Transistors allow monitoring lamp voltage without drawing current from the lamps themselves. This is important in the case of motorcycles that have advanced, adaptive brake lamp controllers that monitor the current consumption of the brake lamps to detect faults. The vehicle could misinterpret the excess current on the brake-lamp supply as a wiring fault.

- LIN networking capability — Although not detailed here, the g-sensor brake lamp will communicate as a slave on a LIN automotive network. It is currently only set up to respond to the 0x3C and 0x3D reserved LIN system command identifiers. For details on LIN messaging configuration, refer to the source code, specifically, the "l_gen.h" and "l_gen.c" files, and the LIN driver manuals for HC908EY16.

5 Software Design

5.1 Software State Machine

The central functionality of the brake lamp design is in the basic state machine for the software. There are essentially six normal operating states with up to 18 sub-states based on turn signal flasher status. Figure 14 shows these states, where the initial reset state is shown as a black dot.

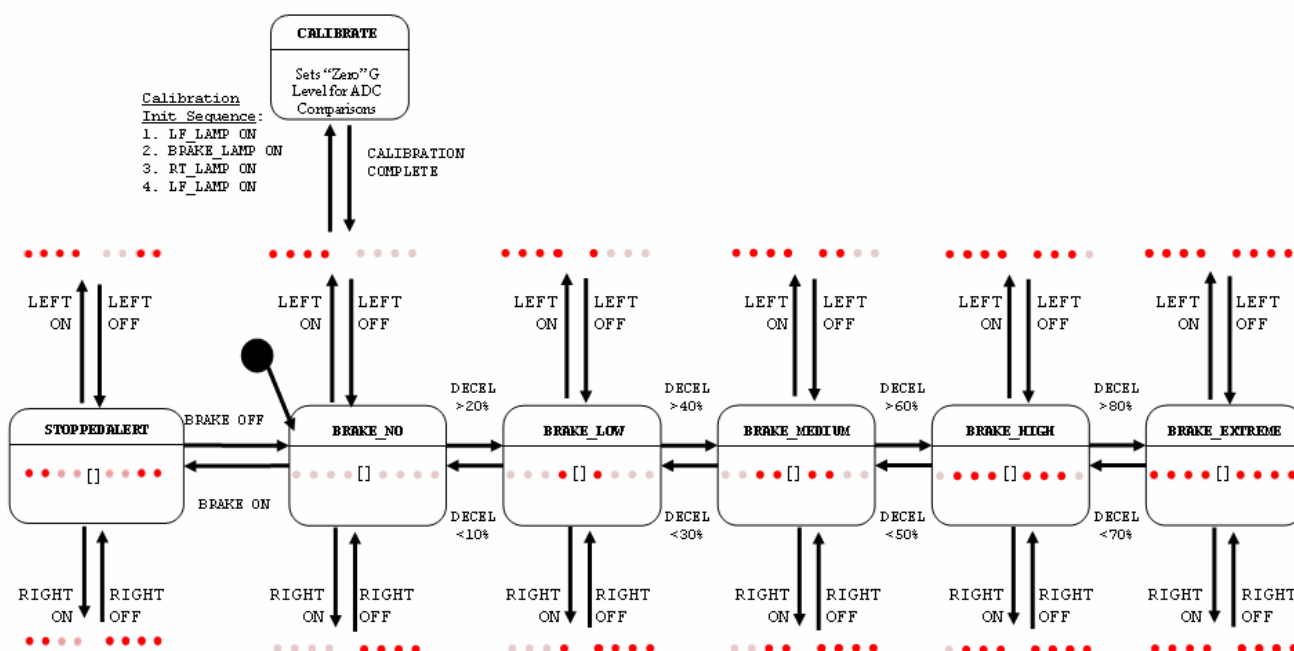

Figure 14. g-Sensor Brake Lamp Software State Machine (Includes Turn Signal Functionality)

The states represent the various deceleration levels and, therefore, the variable LED display patterns. The fundamental states are:

- CALIBRATE - (not implemented in sample code) — When activated, the brake lamp assumes it is not moving and is in the correct neutral position for calibration. For a motorcycle, this requires that the bike stand vertically (not on a kick-stand). Gravity is used to determine the down direction and, therefore, the forward and backward directions and the X,Y, and Z components of sensor data required to measure deceleration in the forward direction of travel.

NOTE

The following states contain three sub-states for left, right, or both turn signals activated. Left turn only and right turn only states are shown in the state machine diagram, but not the case of both left and right active at the same time. This would be applicable only to vehicles with emergency flashers where both turn signals blink together. This is less common in motorcycles.

- **STOPPEDALERT** — Displays the outside two pairs of HBLEDs when there is little or no deceleration, but the vehicle brake lamp is turned on (indicating that the driver is activating the brakes). This emulates a standard third brake lamp at low decelerations or traffic lights, to allow a motorcycle stopped at a traffic light to flash this brake lamp to warn cars approaching from behind that the motorcycle is present or stopped. Tapping the brake lever causes this flash without braking the vehicle. Visibility at traffic lights is a common motorcyclist concern.
- **BRAKE_NO** — Displays no HBLEDs and is entered when there is little or no deceleration.
- **BRAKE_LOW** — Displays one pair of HBLEDs for low decelerations (20% to 40% of maximum deceleration will activate this state).
- **BRAKE_MEDIUM** — Displays two pairs of HBLEDs for moderate decelerations (40% to 60% of maximum deceleration activates this state).
- **BRAKE_HIGH** — Displays three pairs of HBLEDs for hard decelerations (60% to 80% of maximum deceleration activates this state).
- **BRAKE_EXTREME** — Displays four pairs of HBLEDs for extremely hard decelerations (80% and greater of maximum deceleration activates this state). Generally this state is applicable only to emergency situations. Upon entry into this state, a timer latches the software in brake_extreme state to maintain the state even after deceleration. When the timer expires, the deceleration measurements resume control of determining the brake-lamp status. The timer latch is necessary in emergency braking situations as warning that traffic should continue for at least a few seconds because the circumstances causing the emergency stop are probably still present.

When a left or right turn signal (or both) is activated, a sub-state is entered from the main braking level state. The only difference is in the HBLED display. When one turn signal is active, four HBLEDs are lit, and the other side displays the deceleration level, as determined by the braking force. In its current form, the software supports only one signal at time with at least some time between with neither lamp active.

5.2 Accelerometer Initialization and Calibration

With the ability to measure acceleration accurately in all three axes, the g-sensor brake lamp can be calibrated to any mounting angle. Since gravity exerts 1-g of force directly down, the MMA7260Q measures this accurately. The force that appears in each axis from the sensor gives the MCU enough information to determine the brake lamp's mounting position. Since the HBLEDs are always mounted on one side of the board and the MMA7260Q is always mounted on the other, assume the brake lamp would be mounted with the HBLEDs facing the rear of the vehicle. This gives the last piece of data required to determine the forward direction of travel as a function of the X, Y, and Z axis of the accelerometer.

For example in Figure 15, a board is mounted parallel to the vehicle's rear axle, but with the HBLEDs pointing at the sky at a 45° angle instead of facing the horizon directly. This means that from the rear of the vehicle, the board appears level from left to right, but the top of the board leans toward the front of the vehicle and the HBLEDs point up. Given the orientation of the MMA7260Q, the sensor outputs voltages indicating an X axis of +0.5g, a Y axis of 0g, and a Z axis of -0.5g. Because the mounting angle is 45 degrees to the direction of travel, the motorcycle's deceleration is equally observed in the X and Z axes equally. When the board is mounted horizontally level, the deceleration is always measured in only the X and Z axes. Similarly, if the board were mounted so that the HBLEDs were vertically aligned, the deceleration is always a function of the Y and Z axes.

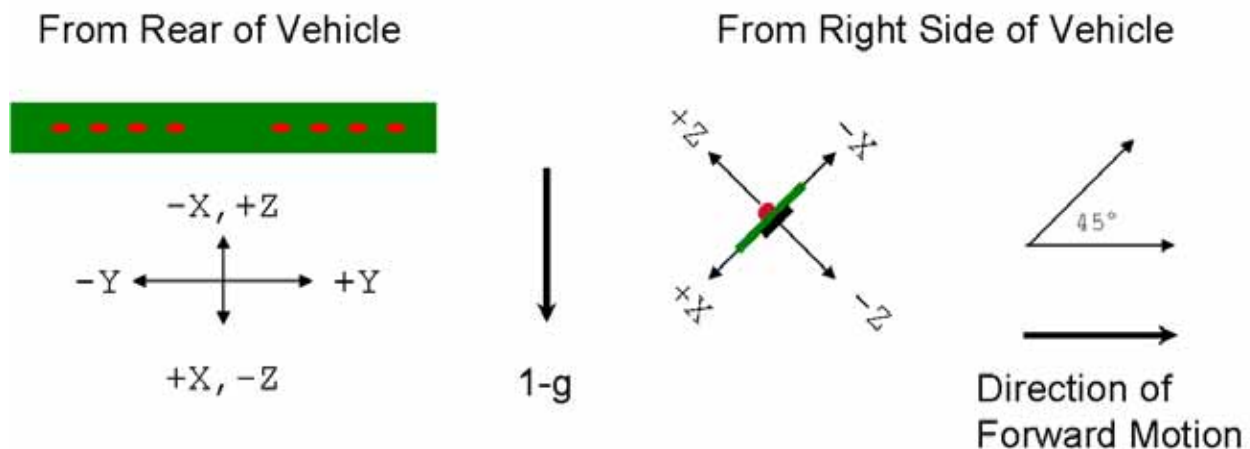

X, Y, and Z indicate direction of mass motion as seen by the MMA7260Q

Figure 15. g-Sensor Brake Lamp Orientation Mounting Calibration Example

To establish the correction factors for vehicle deceleration, consider the direction and orientation of the axes of the sensor relative to the axis of travel. This calibration algorithm is not currently implemented in the software, but the deceleration thresholds are saved in an array in flash memory to facilitate implementing this type of calibration algorithm. The data sheet for the MMA7260Q contains information on the orientation of the sensor relative to the package to aid in determining the mounting angle of a PCB in the earth's gravity field.

6 Looking Forward

Possible design improvements:

- Variable blink rate for each braking level — Deceleration rates would increase, more HBLEDs would light and also blink faster. Blinking attracts attention and implies greater urgency.
- Always-on running lights — When the HBLEDs are not lit at full intensity, they could operate at a reduced intensity as a constant running light.
- Implement the calibration algorithm.
- Sequential turn signals — Turn signals that blink sequentially to the left or right, further reinforcing the turn signal message.

References

- Pothole and incline compensation — Because sudden jolts or constant inclines can affect the accuracy of the g-sensor brake lamp and compensation, algorithms can be derived and tested.

7 References

With this application note, the following related files are available for download:

- Software — A complete CodeWarrior™ 5.1 project, written in C language, which includes turn signal and brake lamp monitor support, as well as LIN drivers.
- Hardware gerber files — Orcad files required to manufacture the PCB
- Reference videos — Videos highlighting the operation and function of the g-sensor brake lamp

Additional information is available at www.freescale.com:

- MM908E625 technical data sheet
- MC68HC908EY16 technical data sheet
- DRM083 — *High Brightness LED Driver Using the MM908E625 Design Reference Manual*
- LIN driver manuals for HC908EY16, available on www.freescale.com/LIN
- MMA7260Q technical data sheet
- AN3107 — *Measuring Tilt with Low-g Accelerometers*
- AN3111 — *Soldering the QFN Stacked Die Sensors to PC Board*
- AN3152 — *Using the Wireless Sensing Triple Axis Reference Design*
- RD3152MMA7260Q — *Wireless Sensing Triple Axis Reference Design (ZSTAR)*

8 Schematics

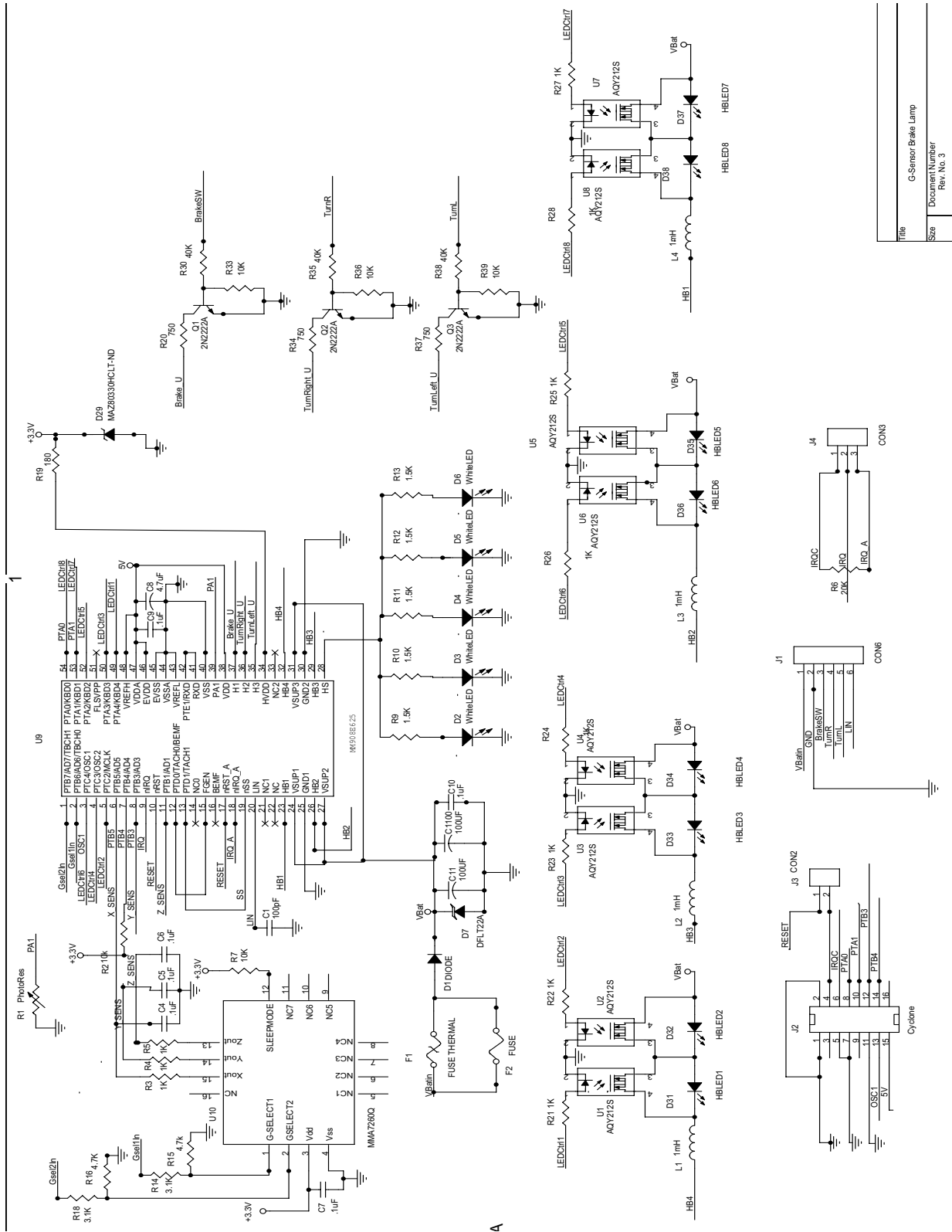

Title	G-Sensor Brake Lamp
Size	Document Number
	Rev. No. 3

g-Sensor High-Brightness LED Brake Lamp, Rev. 0

8.1 Bill of Materials

Table 1. Bill of Materials

Quantity per PCB	Designator	Value / Description	Supplier Part Number	Supplier
1	U9	MM908E625	MM908E625ACDWB	Freescale
1	U10	MMA7260Q	MMA7260Q-ND	Freescale
1	C1	100pF	PCC101CGCT-ND	DIGIKEY
10	C4,C5,C6,C7,C9,C10,C21	0.1uF	PCC1840CT-ND	DIGIKEY
1	C8	4.7uF	587-1294-1-ND	DIGIKEY
2	C11, C1100"	100uF	478-1724-1-ND	DIGIKEY
1	D1	DIODE S	CMS03CT-ND	DIGIKEY
5	D2,D3,D4,D5,D6	White LED	516-1468-ND	DIGIKEY
1	D7	DFLT22A	DFLT24ADICT-ND	DIGIKEY
1	D29	MAZ80330HCLT-ND	MAZ80330HLCT-ND	DIGIKEY
8	D31,D32,D33,D34,D35,D36,D37,D38"	HBLED1 (Red Luxeon I emitter)	LXHL-PD01-LF	FUTURE Electronics
1	F1	NEW FUSE THERMAL	RUEF400-ND	DIGIKEY
1	F2	New Slow FUSE	F2571CT-ND	DIGIKEY
1	J1	CON6	A33965-ND	DIGIKEY
4	L1,L2,L3,L4	1mH	513-1217-1-ND	DIGIKEY
3	Q1,Q2,Q3	2N2222A transistor	568-1741-1-ND	DIGIKEY
1	R1	PhotoRes	PDV-P9001-ND	DIGIKEY
5	R2,R7,R33,R36,R39	10K	P10KACT-ND	DIGIKEY
11	R3,R4,R5,R21,R22,R23,R24,R25,R26,R27,R28	1K	P1.0KACT-ND	DIGIKEY
1	R6	20K	P20KACT-ND	DIGIKEY
5	R9,R10,R11,R12,R13	1.5K	P1.50KFCT-ND	DIGIKEY
2	R14,R16	4.7K	P4.7KACT-ND	DIGIKEY
2	R15,R18	3.1K	P3.3KACT-ND	DIGIKEY
1	R19	180	P180ACT-ND	DIGIKEY
3	R20,R34,R37	750	P750ACT-ND	DIGIKEY
3	R30,R35,R38	40K	P40.2KCCT-ND	DIGIKEY
8	U1,U2,U3,U4,U5,U6,U7,U8	AQY212S	AQY212S-LF	FUTURE Electronics
1	J2	Cyclone Header (2x8 header, 0.1" centers)		
1	J3	CON2 (1x2 header, 0.1" centers)		
1	J4	CON3 (1x3 header, 0.1" centers)		



THIS PAGE IS INTENTIONALLY BLANK

How to Reach Us:

Home Page:

www.freescale.com

E-mail:

support@freescale.com

USA/Europe or Locations Not Listed:

Freescale Semiconductor
Technical Information Center, CH370
1300 N. Alma School Road
Chandler, Arizona 85224
+1-800-521-6274 or +1-480-768-2130
support@freescale.com

Europe, Middle East, and Africa:

Freescale Halbleiter Deutschland GmbH
Technical Information Center
Schatzbogen 7
81829 Muenchen, Germany
+44 1296 380 456 (English)
+46 8 52200080 (English)
+49 89 92103 559 (German)
+33 1 69 35 48 48 (French)
support@freescale.com

Japan:

Freescale Semiconductor Japan Ltd.
Headquarters
ARCO Tower 15F
1-8-1, Shimo-Meguro, Meguro-ku,
Tokyo 153-0064
Japan
0120 191014 or +81 3 5437 9125
support.japan@freescale.com

Asia/Pacific:

Freescale Semiconductor Hong Kong Ltd.
Technical Information Center
2 Dai King Street
Tai Po Industrial Estate
Tai Po, N.T., Hong Kong
+800 2666 8080
support.asia@freescale.com

For Literature Requests Only:

Freescale Semiconductor Literature Distribution Center
P.O. Box 5405
Denver, Colorado 80217
1-800-441-2447 or 303-675-2140
Fax: 303-675-2150
LDCForFreescaleSemiconductor@hibbertgroup.com

Information in this document is provided solely to enable system and software implementers to use Freescale Semiconductor products. There are no express or implied copyright licenses granted hereunder to design or fabricate any integrated circuits or integrated circuits based on the information in this document.

Freescale Semiconductor reserves the right to make changes without further notice to any products herein. Freescale Semiconductor makes no warranty, representation or guarantee regarding the suitability of its products for any particular purpose, nor does Freescale Semiconductor assume any liability arising out of the application or use of any product or circuit, and specifically disclaims any and all liability, including without limitation consequential or incidental damages. "Typical" parameters that may be provided in Freescale Semiconductor data sheets and/or specifications can and do vary in different applications and actual performance may vary over time. All operating parameters, including "Typicals", must be validated for each customer application by customer's technical experts. Freescale Semiconductor does not convey any license under its patent rights nor the rights of others. Freescale Semiconductor products are not designed, intended, or authorized for use as components in systems intended for surgical implant into the body, or other applications intended to support or sustain life, or for any other application in which the failure of the Freescale Semiconductor product could create a situation where personal injury or death may occur. Should Buyer purchase or use Freescale Semiconductor products for any such unintended or unauthorized application, Buyer shall indemnify and hold Freescale Semiconductor and its officers, employees, subsidiaries, affiliates, and distributors harmless against all claims, costs, damages, and expenses, and reasonable attorney fees arising out of, directly or indirectly, any claim of personal injury or death associated with such unintended or unauthorized use, even if such claim alleges that Freescale Semiconductor was negligent regarding the design or manufacture of the part.

Freescale™ and the Freescale logo are trademarks of Freescale Semiconductor, Inc. All other product or service names are the property of their respective owners.

© Freescale Semiconductor, Inc. 2006. All rights reserved.

RoHS-compliant and/or Pb-free versions of Freescale products have the functionality and electrical characteristics as their non-RoHS-compliant and/or non-Pb-free counterparts. For further information, see <http://www.freescale.com> or contact your Freescale sales representative.

For information on Freescale's Environmental Products program, go to <http://www.freescale.com/epp>.