



Repetitive Short-circuit Performances for Dual 24 V High-side Switch Family

1 Introduction

This application note describes the robustness of the MC06XS4200, MC10XS4200, MC22XS4200, and MC50XS4200 devices. These intelligent high-side switches are designed to be used in 24 V systems, such as trucks and busses. They can be used in some industrial and 12 V applications as well. The low $R_{DS(on)}$ channels can control incandescent lamps, LEDs, solenoids, or DC motors. Control, device configuration, and diagnostics are performed through a 16-bit SPI (serial peripheral interface) interface, allowing for easy integration into existing applications. For a complete feature description, refer to the relevant data sheets.

Contents

1 Introduction	1
2 Short-circuit Protections Features	2
2.1 Configurable Latched Overcurrent Protection ..	2
2.2 Severe Short-circuit Protection	3
3 Short-circuit Tests	3
3.1 Test Setup	4
3.2 Short-circuit Test Results	4
3.3 Overload Test Results	7
4 References	8
5 Revision History	9

2 Short-circuit Protections Features

These SMARTMOS devices include dual self-protected high-side switches with enhanced diagnostics. In case of a short-circuit from the HSx pin to the ground, the corresponding high-side switch is immediately turned off via two overload protection features:

- Configurable latched overcurrent protection
- Severe short-circuit protection

These protections are preferred over conventional current limitations, to minimize the thermal overstress within the device in an overload condition. The elevation of junction temperature is drastically reduced to a value which does not affect the device’s reliability.

Moreover, the availability of the load is guaranteed by the auto-retry feature. According to the SPI configuration, the number of retries is limited to 16, or unlimited. The repetition period of auto-retry is also selectable through the SPI from 17.7 ms to 150 ms (typ.).

The high-side switches can be paralleled to drive higher currents. Setting the PARALLEL bit (a bit in the GCR register) is mandatory, to synchronize the turn-off of the outputs, in the event of a short-circuit. If the outputs are not switched concurrently, the device will be damaged, as illustrated in [Figure 1](#).

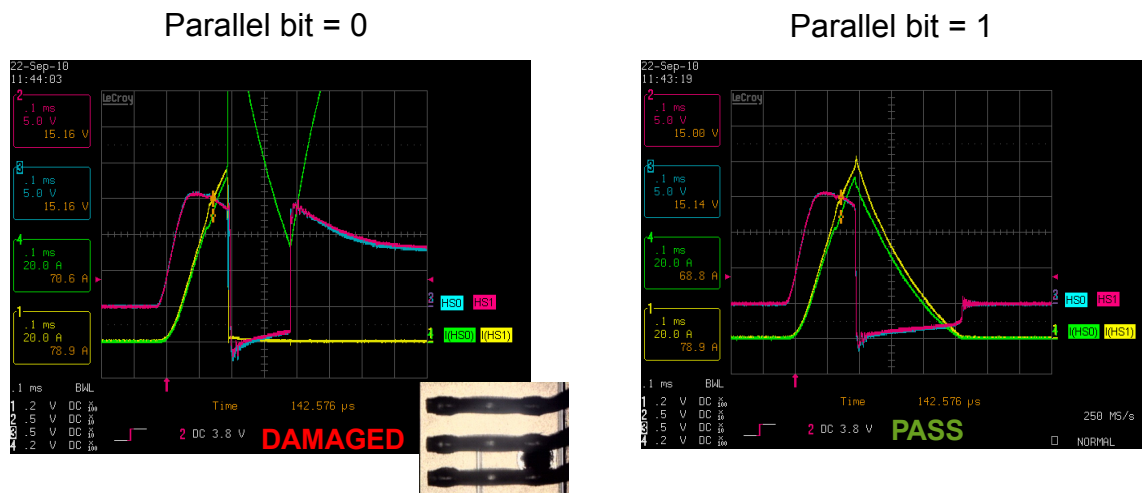

Figure 1. Short-circuit Event with Paralleled MC06XS4200 HSx Pins

2.1 Configurable Latched Overcurrent Protection

The transient overcurrent profile is adjustable, to account for the variability of load and the energy associated with the expected wire harness current capability. The device incorporates multiple configurable overcurrent profiles, to address lighting and DC motor applications, as illustrated in [Figure 2](#).

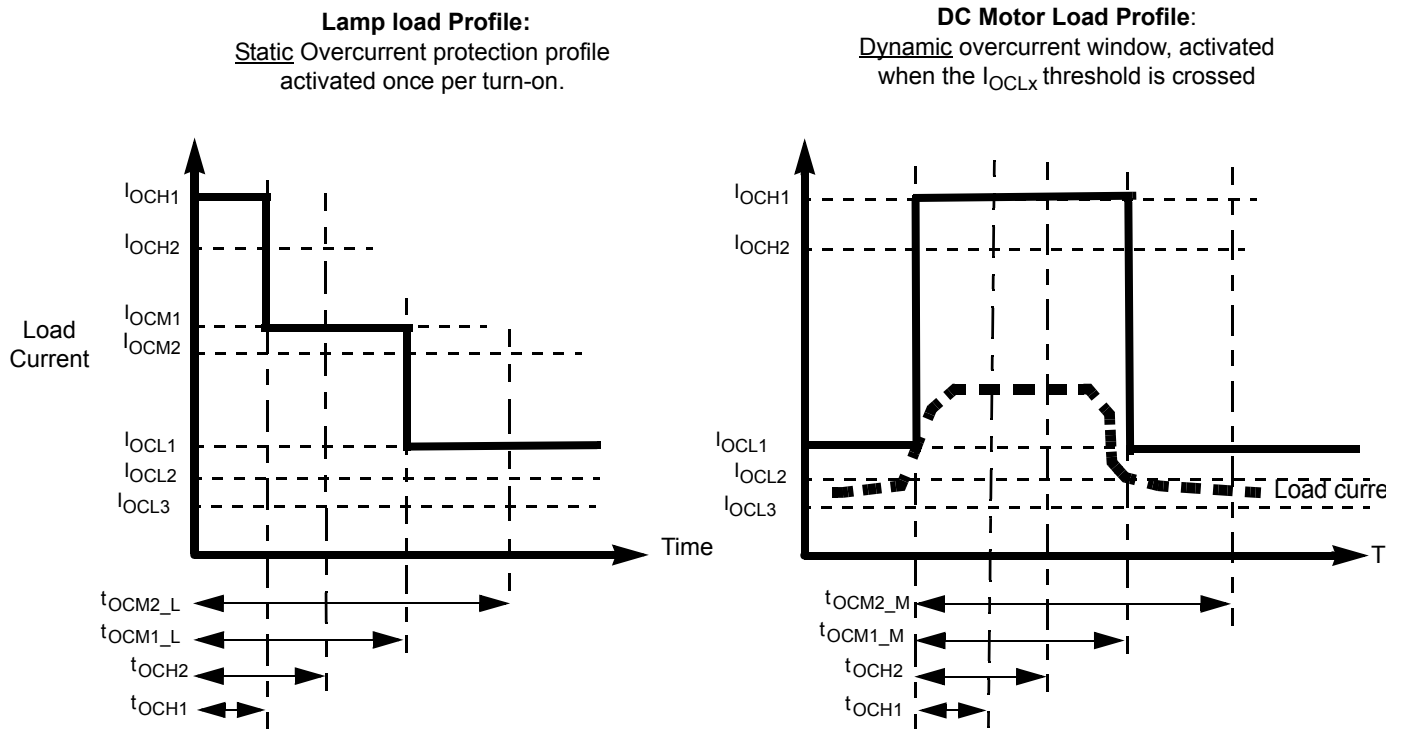

Figure 2. Configurable Overcurrent Profile

The transient overcurrent profile protects the application, if the load is also driven in the PWM (pulse-width modulation) mode.

2.2 Severe Short-circuit Protection

In addition to latched overcurrent protection, a severe short-circuit detection is available during off-to-on switching, to immediately turn off the output.

3 Short-circuit Tests

To accelerate the silicon fatigue, the dual 24 V high-side switches are force to switch “on” and “off,” cyclically. The ambient temperature was fixed at 85 °C. This is the worst case for this type of smart power technology. At least five engineering samples were used per test.

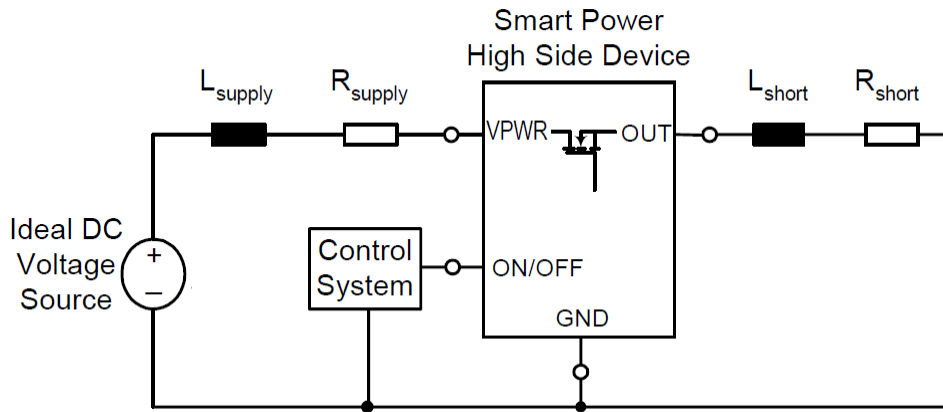

Figure 3. Short-circuit Test Setup

3.1 Test Setup

Figure 3 presents the test setup used. Depending on the test that was performed, the test escape condition was:

- A severe part damage for the “test to fail”
- A defined number of cycles for the “test to pass”

3.2 Short-circuit Test Results

3.2.1 MC06XS4200, MX10XS4200 (PQFN)

Test Description	High-side Operation	Ambient temperature	DC Voltage source	PWM freq.	L _{supply}	R _{supply}	L _{short}	R _{short}	Type of Test	Number of Cycles
Short-circuit at the beginning of the load line and occurred in off-state of high-side switch (cold short)	Single switch with default Lighting Profile	85 °C	32 V	2.0 Hz	5.0 μH	5.0 mΩ	<1.0 μH	12 mΩ	test to pass	1.0 k
Short-circuit at the beginning of the load line and occurred in on-state of high-side switch (hot short)					5.0 μH	5.0 mΩ	1.0 μH	15 mΩ	test to pass	1.0 k
Short-circuit at the end of the load line and occurred in off-state of high-side switch (cold short)					3.7 μH	20 mΩ	24 μH	166 mΩ	test to fail	Figure 4 Figure 5
Short-circuit at the end of the load line and occurred in off-state of high-side switch (cold short)	Paralleled switches with default Lighting Profile				3.7 μH	20 mΩ	24 μH	166 mΩ	test to pass	500 k

For each “test to fail”, the cumulative failures over the number of cycles are presented in [Figure 4](#) and [Figure 5](#). [Gumbel’s predictive law](#), with 95% confidence level, is used to define the number of cycles to failure, down to 10 PPM (parts per million) ($1e-5$).

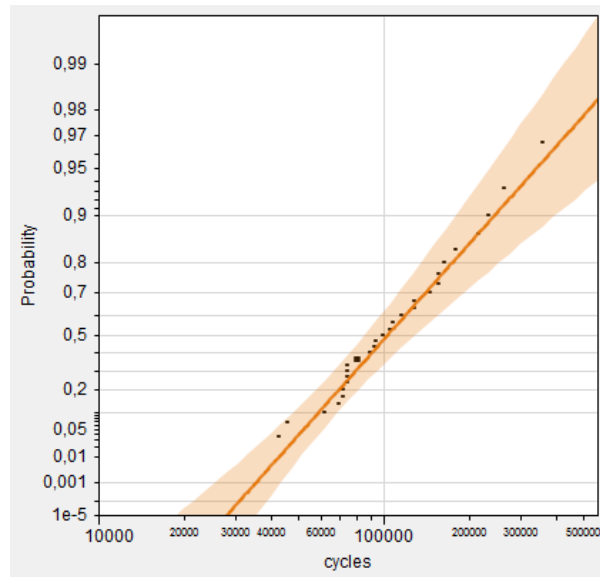

Figure 4. Predictable MC10XS4200 Failures for a Short-circuit at the End of the Load Line

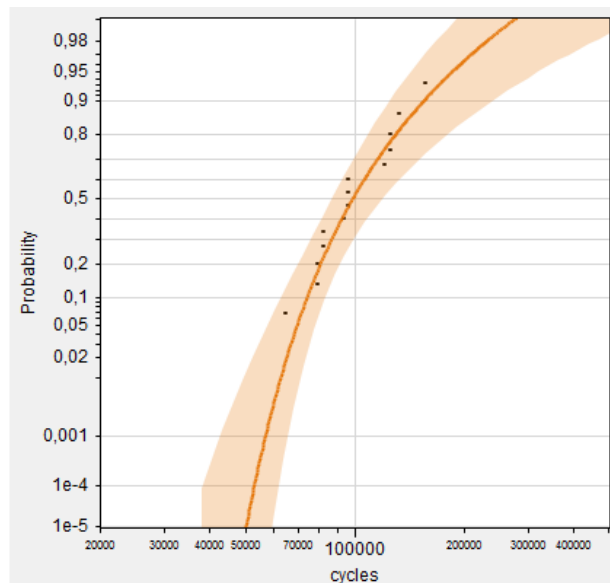

Figure 5. Predictable MC06XS4200 Failures for a Short-circuit at the End of the Load Line

3.2.2 MC22XS4200, MC50XS4200 (eSOIC)

Test Description	High-side Operation	Ambient temperature	DC Voltage source	PWM freq.	Lsupply	Rsupply	Lshort	Rshort	Type of Test	Number of Cycles
Short-circuit at the beginning of the load line and occurred in off-state of high side switch (cold short)	Single switch with default Lighting Profile	85 °C	32 V	2.0 Hz	3.7 μH	20 mΩ	24 μH	166 mΩ	test to fail	Figure 6 Figure 7

For each "test to fail", the cumulative failures over the number of cycles are presented in Figure 6 and Figure 7. LogNormal's predictive law, with 95% confidence level, is used to define the number of cycles to failure, down to 100 and 1000 PPM (parts per million) (1e-5).

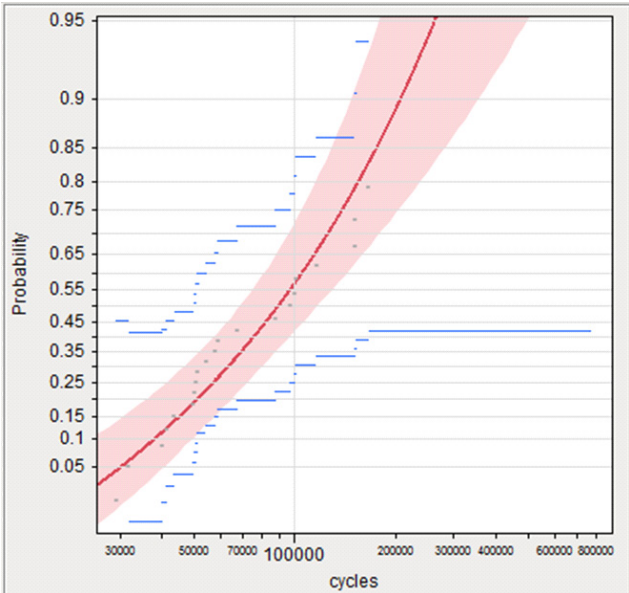

Figure 6. Predictable MC22XS4200 Failures for a Short-circuit at the End of the Load Line

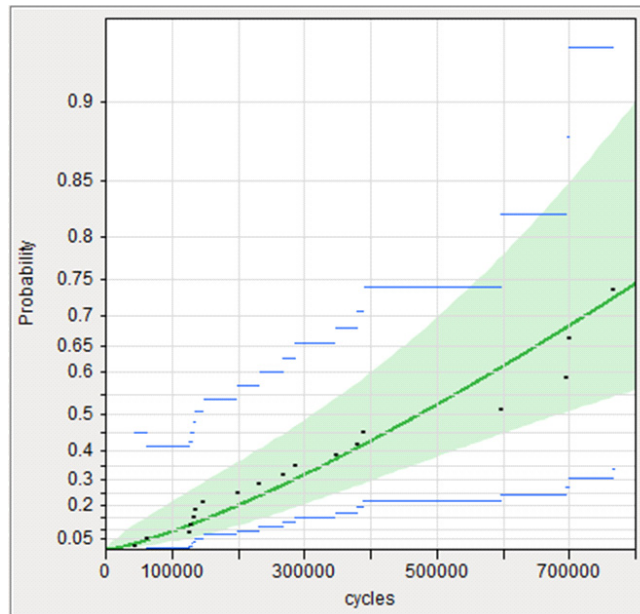

Figure 7. Predictable MC50XS4200 Failures for a Short-circuit at the End of the Load Line

3.3 Overload Test Results

Test Description	High Side Operation	Ambient temperature	DC Voltage Source	PWM freq	Lsupply	Rsupply	Lshort	Rshort	Type of Test	Number of Cycles
Overload 80% of OCHI during toch1 (88 A during 8.6 ms for the MC06XS4200 device)	Single switch with default Lighting Profile	85 °C	32 V	2.0 Hz	5.0 μH	5.0 mΩ	20 μH	350 mΩ	test to pass	1.0 k
Stalled Wiper DC Motor with freewheeling diode (20 A during 350 ms for the MC06XS4200 device)	Single switch with default DC motor Profile			0.5 Hz	5.0 μH	5.0 mΩ	20 μH	stall DC motor	test to pass	1.0 k

4 References

Document Number	Type	Description/URL
MC06XS4200	Data Sheet	Dual 24 V High Side Switch (6.0 mOhm) Data Sheet
MC10XS4200	Data Sheet	Dual 24 V High Side Switch (6.0 mOhm) Data Sheet
MC22XS4200	Data Sheet	Dual 24 V High Side Switch (22 mOhm) Data Sheet
MC50XS4200	Data Sheet	Dual 24 V High Side Switch (50 mOhm) Data Sheet
AN4516	Application Note	IBIS Model File for Dual 24 V High Side Switch Family
AN4473	Application Note	Compact Thermal Model for Dual 24 V High Side Switch Family
AN4474	Application Note	EMC and Fast Transient Pulses Performances for Dual 24 V High Side Switch Family
	Freescale Website	freescale.com
	Freescale Analog Webpage	freescale.com/analog
	Freescale Automotive Applications Webpage	freescale.com/automotive

5 Revision History

Revision	Date	Description of Changes
1.0	10/2012	Initial release
2.0	12/2014	Added short-circuit results for MC22XS4200 and MC50XS4200 Updated document form and style

How to Reach Us:

Home Page:
freescale.com

Web Support:
freescale.com/support

Information in this document is provided solely to enable system and software implementers to use Freescale products. There are no express or implied copyright licenses granted hereunder to design or fabricate any integrated circuits based on the information in this document.

Freescale reserves the right to make changes without further notice to any products herein. Freescale makes no warranty, representation, or guarantee regarding the suitability of its products for any particular purpose, nor does Freescale assume any liability arising out of the application or use of any product or circuit, and specifically disclaims any and all liability, including without limitation consequential or incidental damages. "Typical" parameters that may be provided in Freescale data sheets and/or specifications can and do vary in different applications, and actual performance may vary over time. All operating parameters, including "typicals," must be validated for each customer application by customer's technical experts. Freescale does not convey any license under its patent rights nor the rights of others. Freescale sells products pursuant to standard terms and conditions of sale, which can be found at the following address: freescale.com/SalesTermsandConditions.

Freescale and the Freescale logo are trademarks of Freescale Semiconductor, Inc., Reg. U.S. Pat. & Tm. Off. SMARTMOS is a trademark of Freescale Semiconductor, Inc. All other product or service names are the property of their respective owners.

© 2014 Freescale Semiconductor, Inc.

Document Number: AN4542
Rev. 2.0
12/2014