

Known Spurious Signals in the Freescale MC12311 Sub-GHz Transceivers

Freescale Wireless Connectivity Application Engineering

Contents

1 Introduction

The MC12311 is a highly-integrated, cost-effective, system-in-package (SIP), sub-1 GHz wireless node solution. The MC12311 features a S08QE 8-bit microcontroller with an integrated RF transceiver. It operates over a wide frequency range, including the license-free Industrial, Scientific and Medical (ISM) frequency bands at 315 MHz, 433 MHz, 470 MHz, 868 MHz, 915 MHz, 928 MHz, and 955 MHz. The MC12311 configurations allow designers to minimize the use of external components.

Using a reference crystal of 30 or 32 MHz, the transceiver covers 3 RF bands: 290–340 MHz, 424–510 MHz, and 862–1020 MHz. A clock signal derived from that reference crystal can be routed across the board to the MCU portion of the IC, where it can be used to generate a 48 MHz MCU clock. Alternately, an internal low-power, low frequency clock in the MCU itself can operate the MCU.

While the exact implementation is proprietary, the diagrams that follow are simplified for discussion. The LO block generates the Local Oscillator for the receiver. That signal can instead be digitally modulated and routed to the power amplifier(s) to serve as the transmit signal.

1	Introduction.....	1
2	Issue with PLL-generated spurious signals.....	3
3	Finding at-risk frequencies.....	7
4	Dealing with spurious signals.....	8
5	Reference oscillator and potential spurious signals.....	10
6	Summary.....	11
7	Revision history.....	11

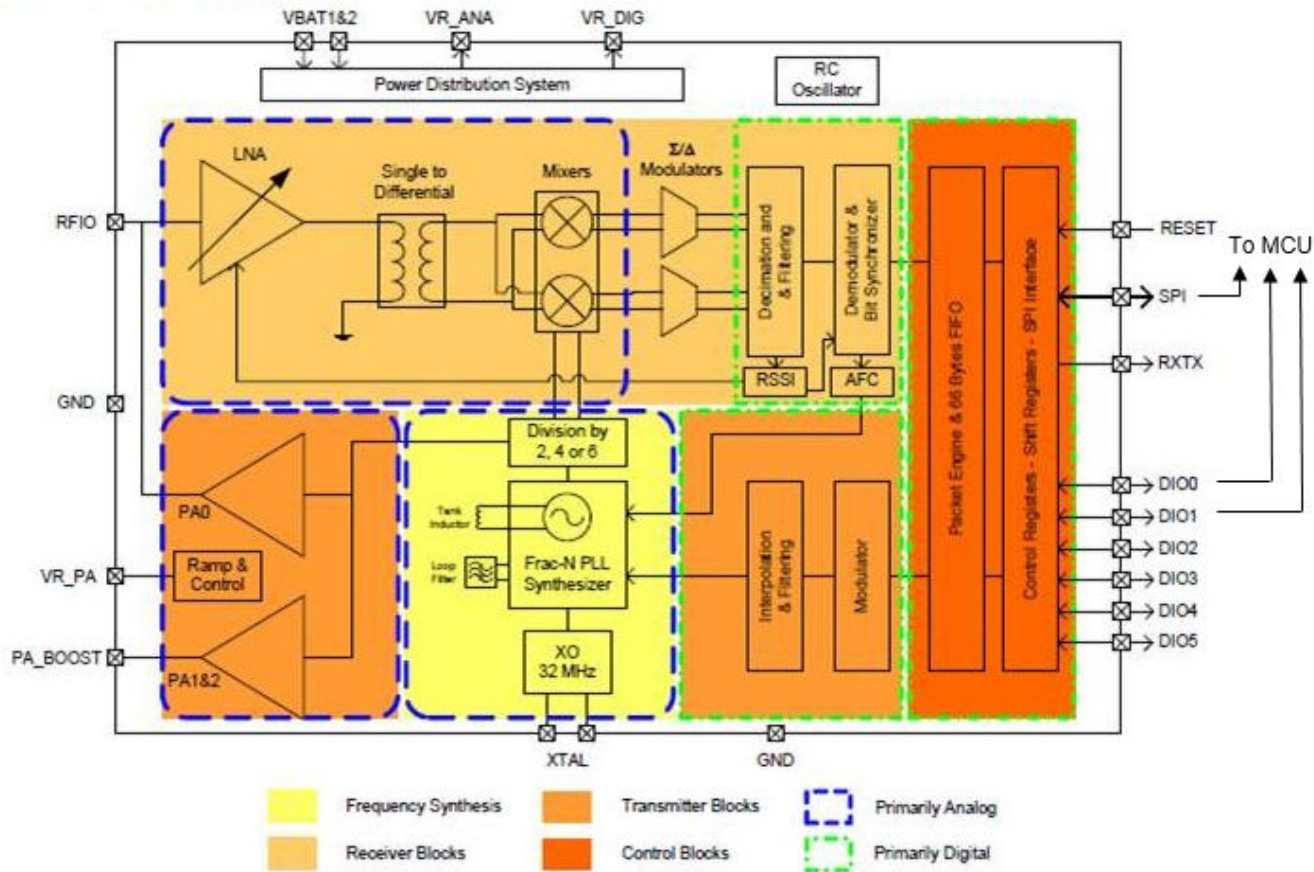

Figure 1. Transceiver block diagram

The PLL runs at approximately 1800 MHz. This internal signal can be divided by 1, 2, or 3 resulting in: 1800, 900, or 600 MHz. This is fed to the quadrature generator, which includes a further divide-by-2, producing IQ signals needed for the receiver. Only one is needed for the transmitter. The total divide ratio of 2, 4, or 6, results in the required Receiver LO or TX signal in the range of 900, 450, or 300 MHz.

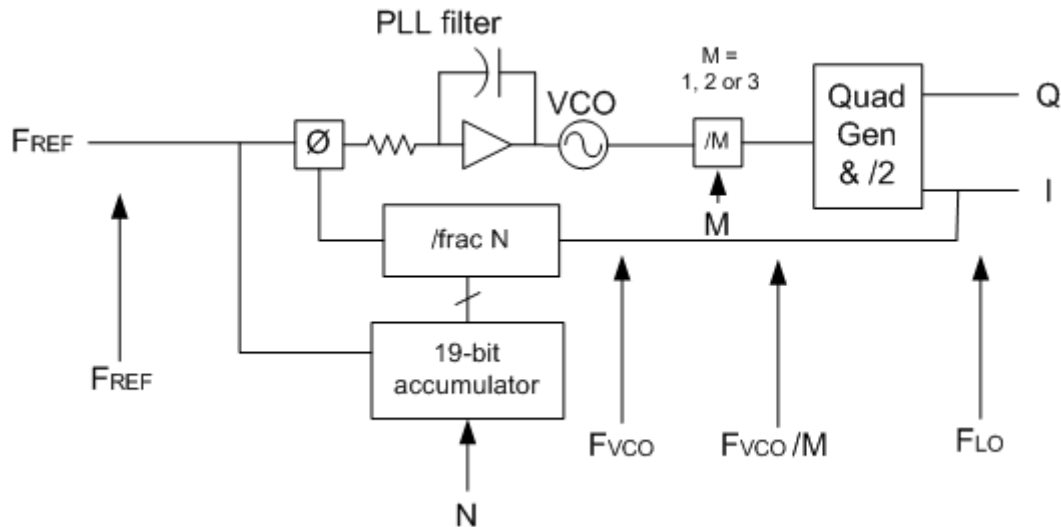

Figure 2. LO Block Simplified Block Diagram

2 Issue with PLL-generated spurious signals

Generally, a spurious signal is any emission that is not directly related to the carrier frequency. Hardware emissions specifications for various world-wide radio standards limit the level of spurious signals permitted, the user must avoid generating spurious signals.

2.1 Spurious emissions

The internally generated clock or reference signals and their harmonics can couple on the silicon die of the transceiver into the LO Synthesizer, and create spurious signals on the transmitted signal. Therefore, synthesizer spurs and reference oscillator spurs are all considered spurious emissions.

2.2 Harmonics

Harmonics are often treated to a different limit than other spurious signals, due to the way they are generated and suppressed (output filter). Therefore, they are not addressed in this application note.

- The harmonics of the reference oscillator can couple to the PLL circuitry, and any integer harmonic landing near an active frequency is passed to the LO and transmitter, or they mix.

2.2.1 Three major spur families

2.2.1.1 Reference harmonics in-band

Issue with PLL-generated spurious signals

Integer harmonics of the reference crystal landing in the operate band (F_{LO}) are considered the strongest spur family. For convenience, we call these first order spurious. The signal is injected into the F_{LO} path and creates a fixed spurious signal at the harmonic of the reference. With a 32 MHz crystal, these spurious signals land at channels near the following frequencies: For the 900 MHz band: 864 MHz, 928 MHz, and 960 MHz, and for the 450 MHz band: 448 MHz, 480 MHz, and 320 MHz in the 300 MHz band. This appears as a spurious sideband to a given offset from the carrier. As the signal wraps through the PLL and the dividers, other signals such as the image of the same offset to the other side, and multiples thereof, are created. These figures provide examples of first order spurs around 480 MHz.

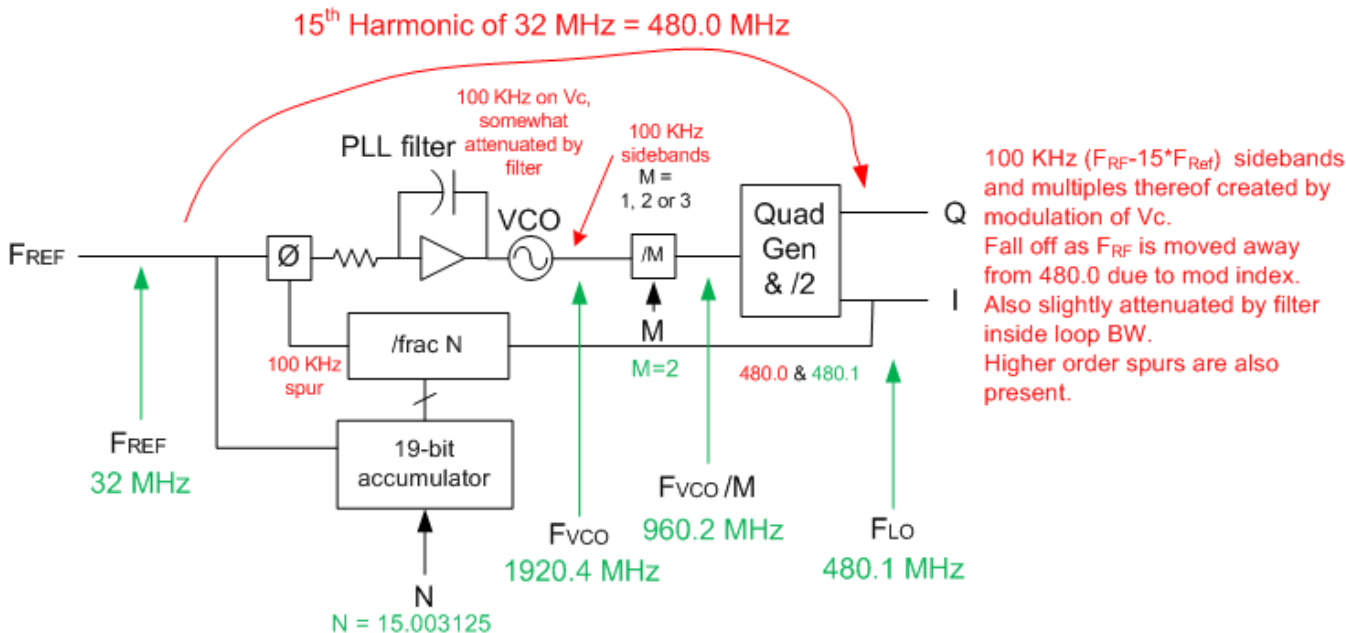

Figure 3. Diagram illustrating first order spurious mechanism, 480 MHz

As seen in the sidebar of the following figure, the spurious signal remains at 480 MHz even as the carrier is moved away.

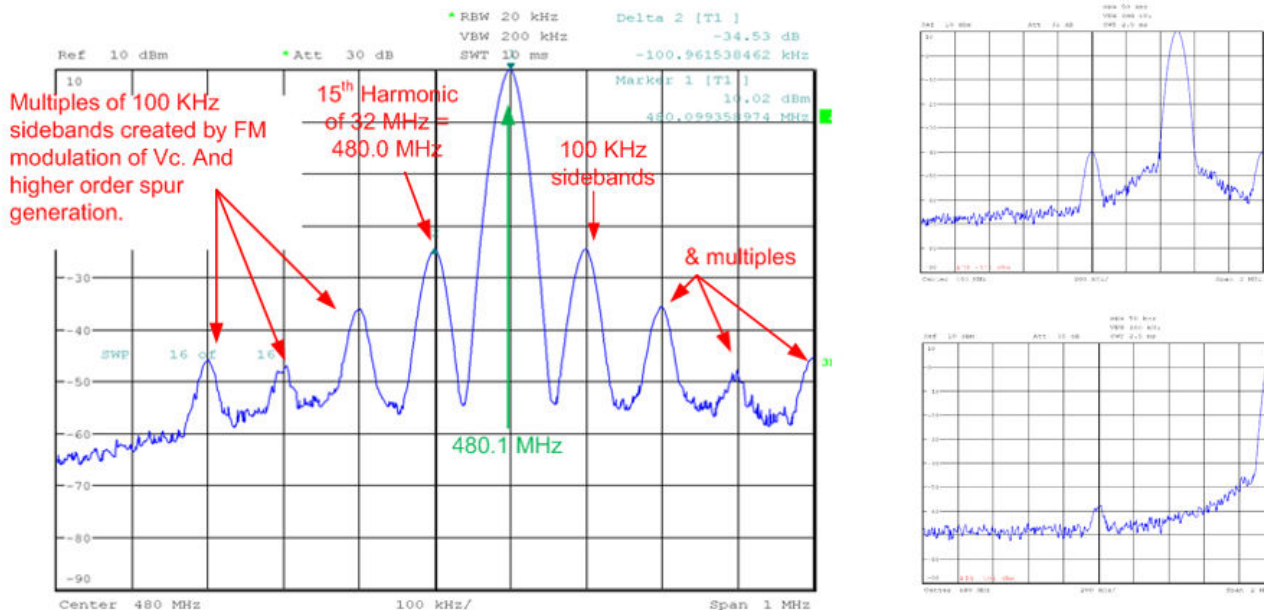

Figure 4. Showing first order (and higher order) spurs, 480 MHz

2.2.1.2 Reference harmonics near internal signal

Integer harmonics landing near the frequency of the internally divided signal, F_{VCO}/M (in the 900 MHz region when $M=2$ is operating in the 450 MHz band). When they are weaker, they mix before the quadrature generator and divider, and create a $2 \cdot F_{offset}$ spur (second order spurious). These figures provide examples of second order spurs around 496 MHz.

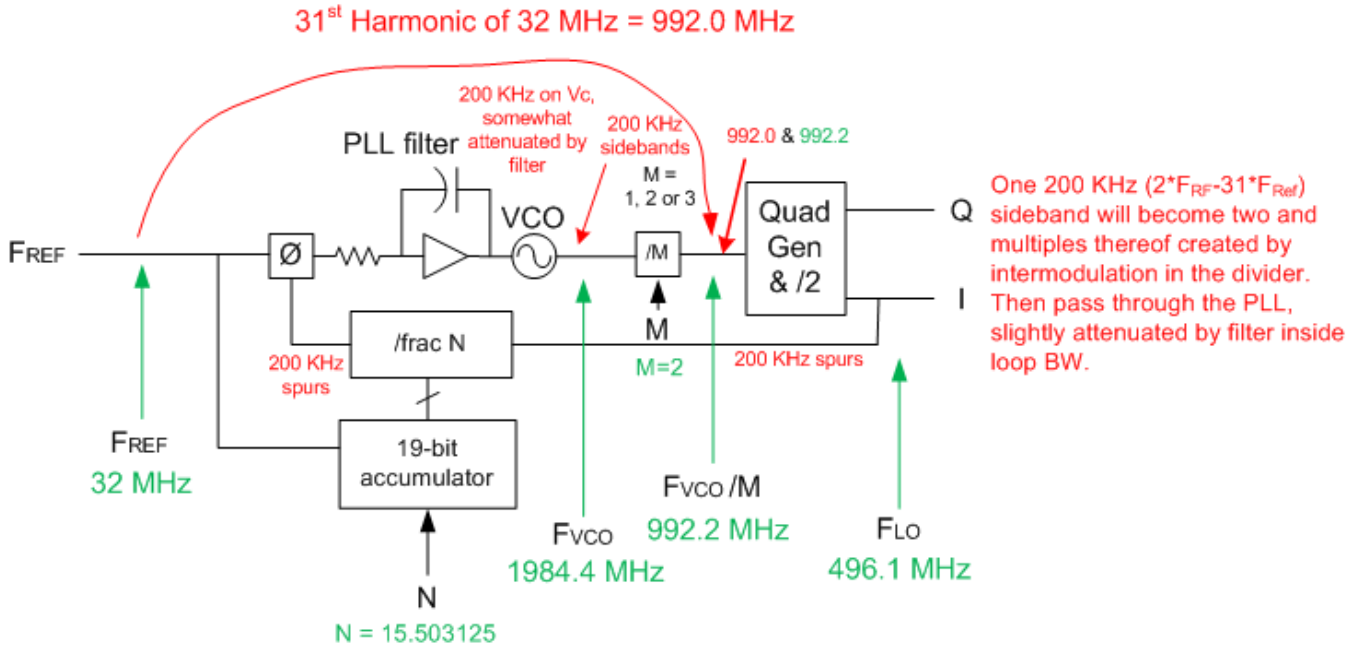

Figure 5. Diagram illustrating second order spurious mechanism, 496 MHz

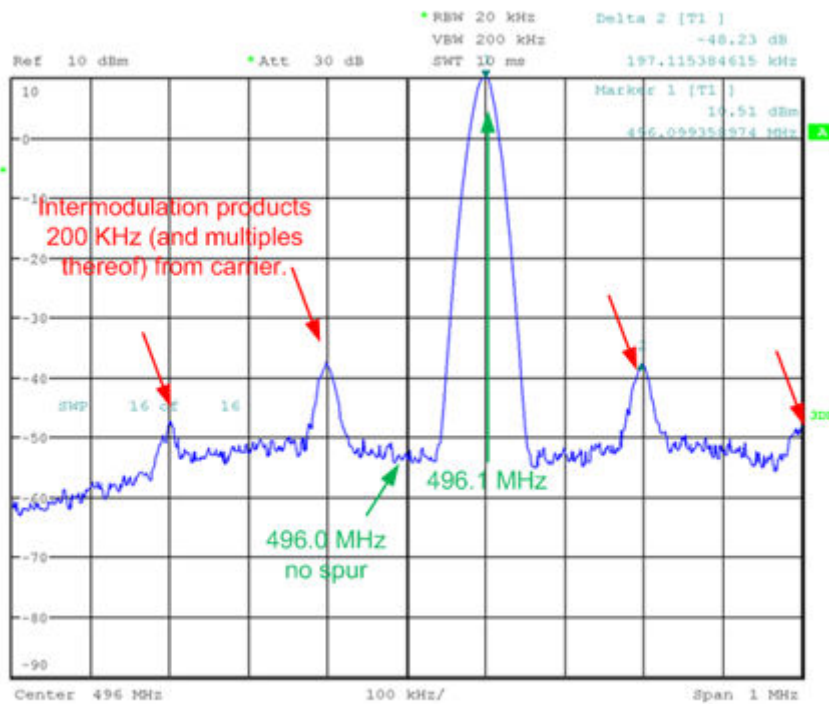

Figure 6. Showing second order (and higher order) spurs, 496 MHz

2.2.1.3 Reference harmonics near VCO

Integer harmonics landing near the frequency of the VCO itself, in the 1900 MHz band (F_{VCO}), are weakest. These mix in the VCO path and create a $4 * F_{offset}$ spur. (third order spurious signals). These figures provide examples of third order spurs around 472 MHz.

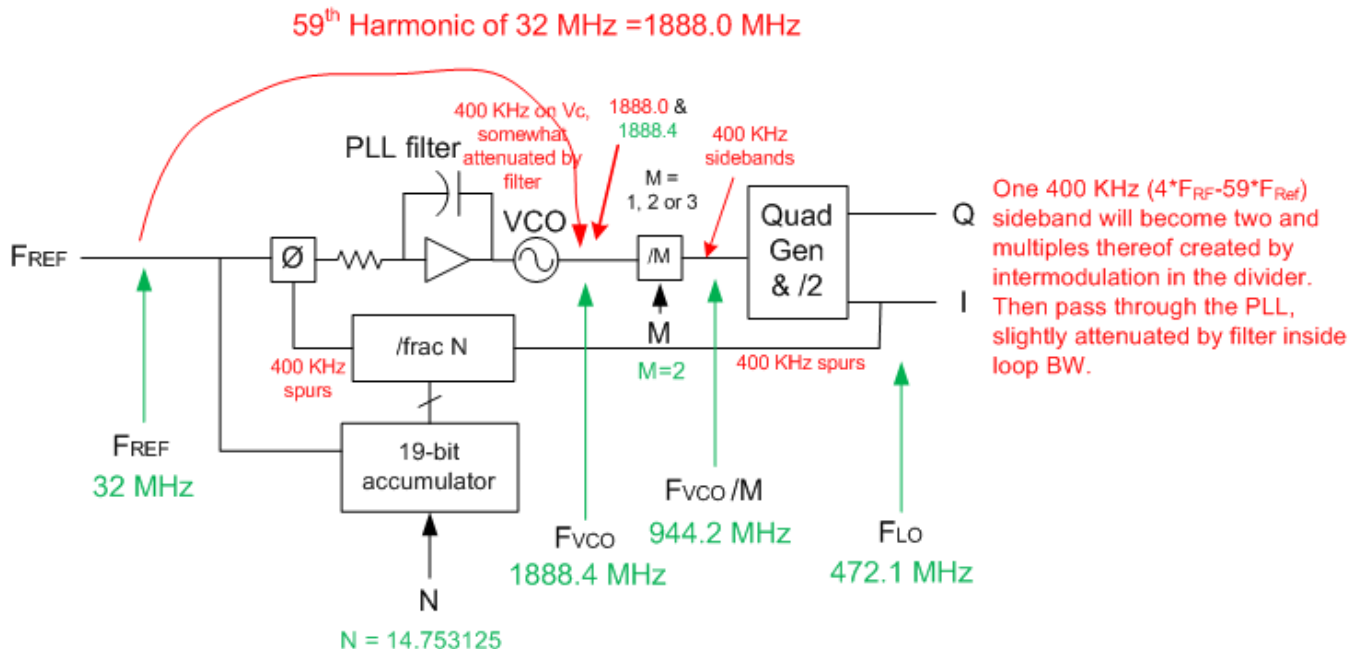

Figure 7. Diagram illustrating third order spurious mechanism, 472 MHz

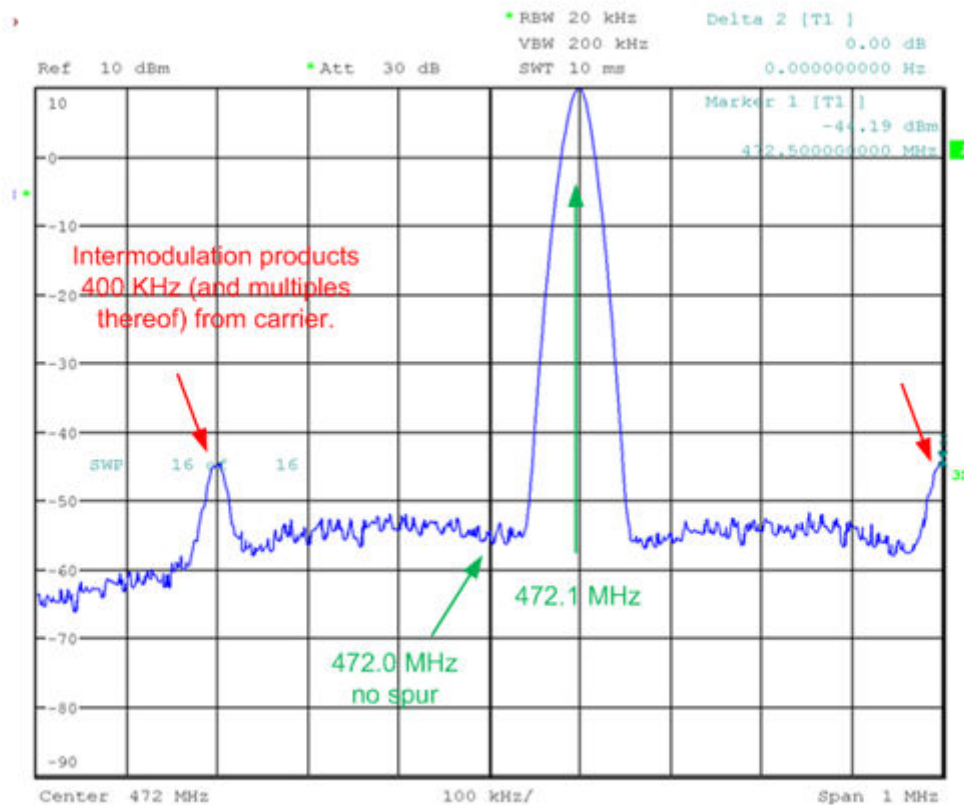

Figure 8. Showing third order spurs, 472 MHz

3 Finding at-risk frequencies

Spurious signals have been observed on only a few channels in a given band. To avoid searching every channel on a spectrum analyzer, a simple calculation can predict which frequencies cause spurious, and the nearby channels can be tested.

By creating a spreadsheet, the user can build a spurious map showing where spurious signals occur. On each row in the first column, list the frequency of integer megahertz steps of F_{RF} of the band in question. With F_{REF} topping certain columns, each cell in that column has a formula to divide that row's F_{RF} by the F_{REF} . Include similar columns for FVCO and FVCO/M. Search for or create a flag that looks for integer numbers in the divide ratios (FLO/F_{REF} , $(FVCO/M)/F_{REF}$ and $FVCO/F_{REF}$) calculated in the cells.

The spurious-map segment in the following figure shows that 480 MHz has spurious based on FLO. These are called first-order spurious, and are known to be the strongest or worst spurs. There are also spurious signals near 496 MHz and 472 MHz, which are second and third order spurious signals that have been previously described.

FLO	32	Fvco/M	32	Fvco	32	FLO	Fvco/M	Fvco
470	14.688	940	29.375	1880	58.75			
471	14.719	942	29.4375	1884	58.875			
472	14.75	944	29.5	1888	59			SPUR
473	14.781	946	29.5625	1892	59.125			
479	14.969	958	29.9375	1916	59.875			
480	15	960	30	1920	60	SPUR	SPUR	SPUR
481	15.031	962	30.0625	1924	60.125			
495	15.469	990	30.9375	1980	61.875			
496	15.5	992	31	1984	62		SPUR	SPUR
497	15.531	994	31.0625	1988	62.125			

Figure 9. Search for channels near integer harmonics of a 32 MHz F_{REF} to identify areas with a risk of spurious signals

Use M=3 when creating a spur search for the 300 MHz band, or M=1 for a 900 MHz band search.

After identifying the frequencies where an integer harmonic of the reference signal occurs, check the spectrum for several megahertz around several adjacent channels above and below that frequency. Depending on the level of the generated spurious signals, some number of close-in channels may cause spurious signals that exceed the permitted level.

4 Dealing with spurious signals

4.1 Selecting F_{REF}

The MC12311 Transceiver allows the reference oscillator to be chosen in the 26 to 32 MHz range, with the 32 MHz being the default.

Selecting a reference frequency that does not have a harmonic that falls in-band at the output, intermediate, or VCO frequencies can avoid spurious. Again, avoiding “first order” spurious is more important than “second order” or “third order” spurious signals, due to the level of spurious created by each mechanism.

There are internal hardware limits on the divide ratio to ensure “illegal” (beyond the VCO tuning range) frequencies cannot be programmed when using a 32 MHz reference. If the chosen alternate F_{REF} requires such a divide ratio to achieve an otherwise “legal” frequency, it may not be possible to tune to that frequency.

All of the internal receive bandwidth signals, bit rate settings, deviation settings, frequency steps, and so on, are derived from F_{REF}. Selecting an alternate F_{REF} requires software being changed to correctly calculate all of these numbers.

The formula to calculate bit rate may result in a bit rate exactly as desired, or the nearest step. For instance, 32 MHz and 30 MHz can both divide down to create a 100 kbit/s bit rate exactly. However, the 30 MHz F_{REF} creates a 4800 bit/s bit rate exactly, whereas the 32 MHz F_{REF} creates 4800.48 bit/s, or nearly a half Hz error. This may seem small, but that 100 ppm error exceeds some specs. Two boards with the same bit rate offset can communicate with each other, but a board with a given bit rate offset communicating with a board (of legacy design for instance, or a competitor’s or partner’s product) without that same offset in bit rate may result bit or packet errors.

All of these issues should be considered before finalizing a decision on using an alternate F_{REF}.

The two standard reference frequencies commonly used with the MC12311 are 30 MHz and 32 MHz. While 32 MHz is recommended for most applications, 30 MHz was chosen for Japan 920 MHz band products to avoid spurious signals in band, and is supplied in MC12311 boards. Both 30 MHz and 32 MHz references create a spurious-rich region near 480 MHz.

4.2 PLLBW

While only one red arrow is shown in the previous diagrams symbolizing on-chip leakage contributing to the generation of spurious signals, there are actually multiple such paths some inside the PLL loop bandwidth and some outside.

For spurious signals created by mixing components present inside the PLL loop, decreasing the loop bandwidth reduces those spurs. Use RegTestPLL 0x5F for this. Decreasing the loop bandwidth also reduces phase noise sidebands.

With changes to the default PLL Bandwidth, tests should be performed measure improvement in spurs while also checking that there is no adverse affect on modulation caused by the narrower loop bandwidth. Where-as leakage paths bypassing the PLL filter, adjusting loop bandwidth has less of an effect.

The figure provides a comparison of the effect of PLL bandwidth, showing 600 KHz on the left, and 75 KHz on the right on spurious on the 480.1 MHz signal. Note one pair of spurious is only marginally affected by PLLBW.

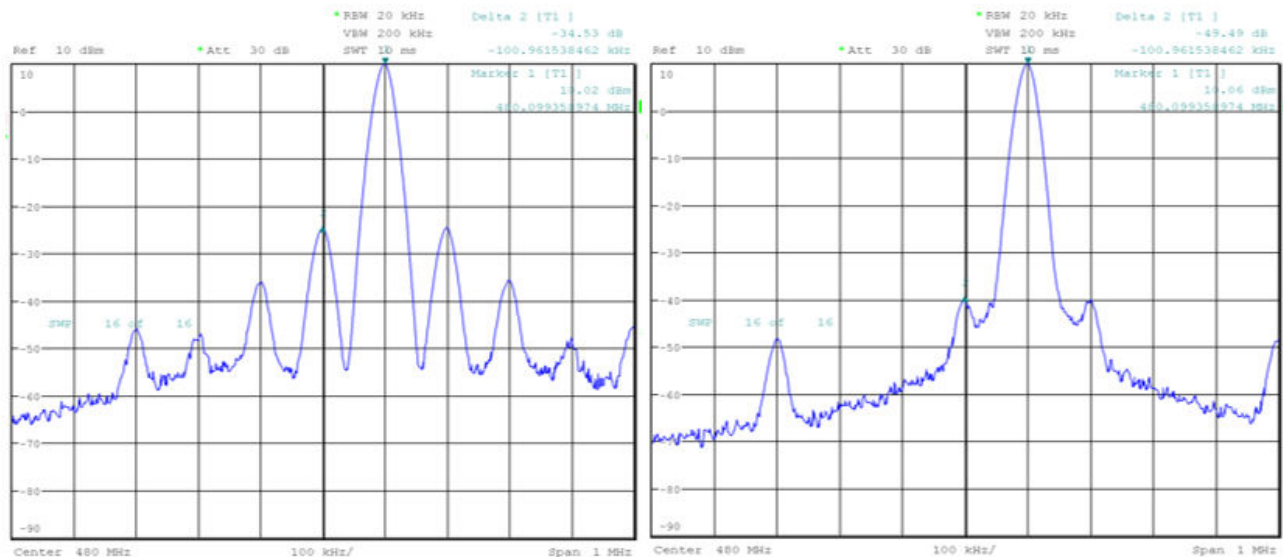

Figure 10. Comparison of effect of PLL bandwidth

4.3 Channel lockout

After mapping out regions of likely spurious signals and choosing an F_{REF} to eliminate spurious signals where feasible, and adjusting PLLBW to reduce those that remain, it may be necessary to lockout certain channels.

Using the previous examples, the 480 MHz region is known to generate spurious. There were 100 KHz and higher spurs on 479.9, 481.1, and other nearby channels.

NOTE

The channel lockout solution, especially with frequency hopping, may limit system performance, standards compliance or interoperability with legacy or alternate vendor equipment.

Reference oscillator and potential spurious signals

The figure below shows a spectrum plot taken from a signal in a region (470 MHz) where PLL spurious signals are not generated, in comparison to previous figures.

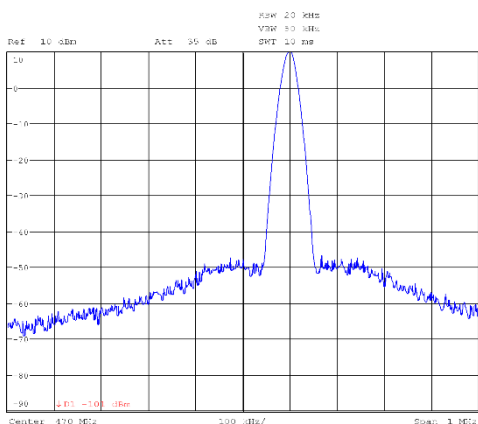

Figure 11. Spectrum plot of a signal in region (470 MHz)

5 Reference oscillator and potential spurious signals

Another completely unrelated mechanism for generating spurious or undesired signals is leakage of the clock frequency off-chip.

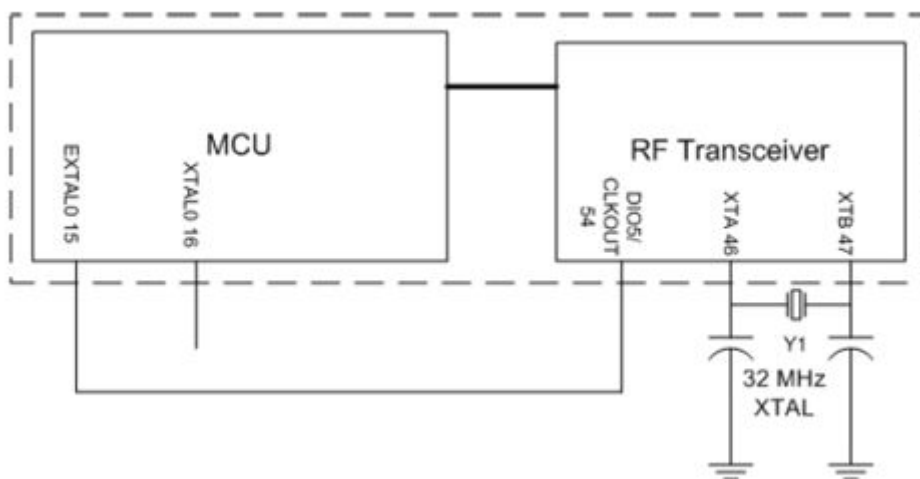

Figure 12. MC12311 Clock connections

The reference for the RF transceiver is typically generated with an off-chip crystal and the on-die oscillator (XTA, XT B).

- 32 MHz is the recommended frequency for most applications.
- 30 MHz is the most common alternate frequency. This would be chosen to move PLL spurious signal out of a desired band.

This reference, at the fundamental frequency or divided down to a lower frequency, is typically routed (off-chip but on-board) from the CLKOUT pin of the transceiver, to the EXTAL0 pin of the MCU, to provide the main clock for the MCU section of the IC.

This reference signal, which is rich in harmonics, routed off-chip, and across the board, can leak into other on-board circuitry and create entirely new spurious signals. It can also be radiated into the air and become an “unintentional radiated emission”, or couple to other circuit elements with off-board wired connections and create “conducted spurious” signals. A 32 MHz F_{REF} can radiate or couple an unwanted signal at 32 MHz or 96 MHz, or cause additional problems.

The CLKOUT path from the transceiver to the MCU should be isolated from other circuitry, routed as controlled impedance, shielded, or run close to ground. Structures that can act as an antenna should be avoided on that path (the MC12311 MRB has a jumper on that path which acts as an antenna). For example, selecting a divide ratio for CLKOUT (in RegDioMapping2) and routing that signal at 2 MHz instead of 32 MHz can reduce radiation simply because the offending structure is a smaller fraction of a wavelength of the lower frequency and less efficient as an “antenna”.

6 Summary

Numerous mechanisms create spurious signals on the carrier or other circuit traces, some of which allow radiated emissions.

- Only specific frequencies (those near harmonics of F_{REF}) are affected.
- Radiated F_{REF} spurs can also occur.

Solutions:

- Selecting a different F_{REF} can move spurious regions out of band.
- A more narrow PLL loop bandwidth eliminates some spurious.
- Locking out channels that fall in spurious regions.
- Careful layout can reduce radiated emissions.
- Selection of CLKOUT can reduce radiated emissions.

7 Revision history

The following table contains a history of changes made to this user's guide.

Table 1. Revision history

Revision number	Date	Substantive changes
0	09/2015	Initial release



How to Reach Us:

Home Page:
freescale.com

Web Support:
freescale.com/support

Information in this document is provided solely to enable system and software implementers to use Freescale products. There are no express or implied copyright licenses granted hereunder to design or fabricate any integrated circuits based on the information in this document.

Freescale reserves the right to make changes without further notice to any products herein. Freescale makes no warranty, representation, or guarantee regarding the suitability of its products for any particular purpose, nor does Freescale assume any liability arising out of the application or use of any product or circuit, and specifically disclaims any and all liability, including without limitation consequential or incidental damages. "Typical" parameters that may be provided in Freescale data sheets and/or specifications can and do vary in different applications, and actual performance may vary over time. All operating parameters, including "typicals," must be validated for each customer application by customer's technical experts. Freescale does not convey any license under its patent rights nor the rights of others. Freescale sells products pursuant to standard terms and conditions of sale, which can be found at the following address: www.freescale.com/salestermsandconditions.

Freescale, the Freescale logo, and Kinetis are trademarks of Freescale Semiconductor, Inc., Reg. U.S. Pat. & Tm. Off. All other product or service names are the property of their respective owners. All rights reserved.

© 2015 Freescale Semiconductor, Inc.

Document Number AN5027
Revision 0, 09/2015

