

**Twin CODEC Expansion Board
for the DSP56000
Application Development System**

DSP

Freescale Semiconductor, Inc.



MOTOROLA

**For More Information On This Product,
Go to: www.freescale.com**



Motorola Digital Signal Processors

Twin CODEC Expansion Board for the DSP56000 Application Development System

Prepared by Ralph Weir
DSP Applications
East Kilbride, Scotland
Eric Cheval
DSP Applications
Austin, Texas

Motorola reserves the right to make changes without further notice to any products herein to improve reliability, function or design. Motorola does not assume any liability arising out of the application or use of any product or circuit described herein; neither does it convey any license under its patent rights nor the rights of others. Motorola products are not designed, intended, or authorized for use as components in systems intended for surgical implant into the body, or other applications intended to support or sustain life, or for any other application in which the failure of the Motorola product could create a situation where personal injury or death may occur. Should Buyer purchase or use Motorola products for any such unintended or unauthorized application, Buyer shall indemnify and hold Motorola and its officers, employees, subsidiaries, affiliates, and distributors harmless against all claims, costs, damages, and expenses, and reasonable attorney fees arising out of, directly or indirectly, any claim of personal injury or death associated with such unintended or unauthorized use, even if such claim alleges that Motorola was negligent regarding the design or manufacture of the part. Motorola and  are registered trademarks of Motorola, Inc. Motorola, Inc. is an Equal Opportunity/Affirmative Action Employer.

INTRODUCTION

The CODEC is an integrated analog-to-digital converter (ADC), digital-to-analog converter (DAC), and filter intended for use in telecommunications applications. It has been designed for a sample rate of 8 kHz, the standard telecommunications sampling frequency, and has a serial interface that may be used in a time-division multiplexed (TDM) system.

The filter implemented in the CODEC tailors the incoming analog signal for transmission through a telephone channel. It has a bandpass characteristic, cutting off at 300 Hz and 3.4 kHz; this also performs the anti-aliasing function for the ADC.

This application report describes a twin CODEC board designed to facilitate the development of telecommunication applications around the DSP56000 Family members. The board is intended for any situation where a DSP module is required to link two analog lines, as in the case of a line repeater or a telephone handset; it can also be used to develop applications requiring a single CODEC.

The CODEC board is designed to interface directly to the DSP, using the synchronous serial interface (SSI). The SSI is capable of generating all signals required for a serial CODEC, creating an interface with no glue logic. It is possible to create systems with many CODECs, all under the control of the DSP using the SSI communications link. The board described here is a simple example of such a system.

Various software routines are available, giving the DSP the ability to make conversion between the various data formats available from CODECs (linear, A-law, and Mu-law are the three main formats). It is essential that data be in a linear format before DSP processing. The conversion routines are listed in Appendix E; for more details, consult application note ANE408 or the Dr. BuB bulletin board. Printed circuit board (PCB) artwork for the expansion board is included in Appendix F.

DSP56000/DSP56001 SSI

The DSP56000 SSI is a powerful serial interface that may be used with many existing serial CODECs, COFIDECs (monocircuits), and serial ADCs/DACs. It is also a suitable medium for building serial networks of DSPs based on a TDM access protocol. A complete description of the interface can be found in DSP56000UM/AD Rev.2 *DSP56000/DSP56001 Digital Signal Processor User's Manual*, Section 7. A short description of the interface is presented in the following paragraphs.

The SSI is a six-pin interface that may be configured for synchronous or asynchronous exchange, continuous or gated clock, and normal or network mode.

Clocks may be generated internally and output or may be input from the external host system. The six pins are not necessarily used in all configurations, and unused lines may remain as general-purpose I/O.

Like every DSP56000/DSP56001 on-chip peripheral, the SSI is a full-duplex, double-buffered, memory-mapped peripheral, mapped into the peripheral area at the top of internal X-memory.

DATA REGISTERS

The SSI interface inputs and outputs the data using two 24-bit data registers mapped at X:\$FFEF:

Write-Only Transmit Data Register (TX)

The transmit shift register is associated with the TX register. The transmit shift register shifts out the data written to the TX register onto the STD pin; when empty, it reads the data in the TX register if any is available. (A transmitter underrun error will occur if no fresh data is present.) The DSP may be programmed for an interrupt when the transfer occurs or may poll the SSI status flags.

Read-Only Receive Data Register (RX)

The receive shift register is associated with the RX register. The receive shift register formats the serial data read from the SRD pin; when full, it transfers the data to the RX register and sets a flag to indicate data is available. (If the data in the RX register is unread by the time the receive shift register is again full, a receiver overrun error will occur.) Unused bits are written as zeros. The DSP may be programmed for an interrupt when the transfer occurs or may poll the SSI status flags.

CONTROL REGISTERS

Four control registers are associated with the SSI:

1. Control Register A (CRA)
2. Control Register B (CRB)
3. SSI Status Register (SSISR)
4. Time Slot Register (TSR)

CRA (16 Low Bits of X:\$FFEC; Read/Write)

This register controls clock and frame sync generation, word length, and number of words per frame.

15	14	13	12	11	10	9	8	7	6	5	4	3	2	1	0
PSR	WL1	WL0	DC4	DC3	DC2	DC1	DC0	PM7	PM6	PM5	PM4	PM3	PM2	PM1	PM0

PSR — Prescaler Range

PSR = 1 enables a divided-by-8 prescaler in the clock generator.

WL1–WL0 — Word Length Control

Selects the number of bits per word (00 for 8-bit data).

DC4–DC0 — Frame Rate Divider Control

Controls the frame divider rate in network mode. In normal mode, these bits control the word transfer rate.

PM7–PM0 — Prescale Modulus Select

Selects the divide ratio for the clock generator.

According to the DSP crystal clock frequency and the required SSI clock rate, the various standard telecommunications frequencies may be generated. The following table details the values of PM7–PM0 for this; note that if the prescaler is used, these values should be divided by 8.

FOSC (MHz)	Maximum Bit Clock	128 kHz	1.536 MHz	1.544 MHz	2.048 MHz	2.56 MHz
16.384	4.096	32	2.67	2.65	2	1.6
18.432	4.608	36	3	2.99	2.25	1.8
20.48	5.12	40	3.33	3.31	2.5	2

When the frame sync has to be generated by the DSP on pins SC1 and SC2, bits DC4–DC0 of CRA and the FSL bit of CRB have to be configured accordingly. For the MC145503 monocircuit, SC2 may be connected directly to TDE/RDE; since these lines should be high during word exchange, the FSL bit in CRB should be cleared.

The CODEC TDE line should be cycled at 8 kHz to provide the sampling rate clock. This defines DC4–DC0 for a single CODEC in normal mode, according to the selected bit clock (SCK). Note that the value for a twin CODEC system is based on cycling TDE at 16 kHz when the line is gated between two devices; thus, the DC4–DC0 value should be halved.

CRB (16 Low Bits of X:\$FFED; Read/Write; Cleared by RESET)

This register controls interrupts from the SSI, enabling of the SSI, and clock frame sync formats. It also contains the control bits for serial control lines SC0–SC2.

RIE — Receive Interrupt Enable

Enables the RX interrupt; the DSP will be interrupted if data is read from the SSI RX register.

TIE — Transmit Interrupt Enable

Enables the TX interrupt; the DSP will be interrupted if data is written to the TX register for SSI transmission.

RE — Receive Enable

Enables the SSI receiver. If this bit is not set, the SSI will never receive any data.

TE — Transmit Enable

Enables the SSI transmitter. If this bit is not set, the SSI will never transmit any data.

MOD — Mode Select

Selects normal mode when clear, network mode when set.

GCK — Gated Clock Control

Selects continuous clock when clear, gated clock when set.

SYN — Synchronous/Asynchronous

Selects asynchronous mode when clear, synchronous mode when set.

FSL1 and FSL0 — Frame Sync Length Flags 1 and 0

Selects frame sync length — word length when clear, bit length when set.

SHFD — Shift Direction Flag

Transmit shift register shifts MSB first when clear.

SCKD — Clock Source

Selects external clock when clear, internal clock when set.

SCD2, SCD1 and SCD0 — Serial Control Direction Flags 2, 1 and 0

Controls the direction of the SC2, SC1 and SC0 lines; clear for input.

OF1 and OF0 — Serial Output Flags 1 and 0

Output data for SC1 and SC0 when configured as an output.

SR (8 Low Bits of X:\$FFEE; Read-Only)

The SR provides status information to the DSP.

RDF — Receive Data Full

Set when the RX register contains valid received data which may be read by the DSP.

TDE — Transmit Data Empty

Set when the TX register is empty and ready to receive another word for transmission. Note that this does not mean the the last word has been fully transmitted since the SSI port is a buffered interface.

ROE — Receiver Overrun Error

Set when the DSP overwrites valid, but unread, data in the RX register. This condition would occur if the SSI was receiving a stream of serial data, and, for some reason, the DSP did not read one word. This condition may be used to provide an alternative interrupt to the DSP or may be polled to check for the error condition.

TUE — Transmitter Underrun Error

Set when a frame sync occurs but the SSI has no data to transmit. This condition may cause an error with many serial devices; it may be used to switch to the transmit exception interrupt vector or may be polled to detect the error.

RFS — Receive Frame Sync

Set when a received frame occurs during the reception of a word when in network mode. This indicates the first time slot.

TFS — Transmit Frame Sync

Set when a received frame occurs during the transmission of a word when in network mode. This indicates the first time slot.

IF1 and IF0 — Serial Input Flags 1 and 0

These flags contain the data on the SC1 and SC0 lines when configured as input. They are latched from SC1 and SC0 during reception of the MSB of each incoming word.

TSR (X:\$FFEE)

This 8-bit write-only time slot register is used in network mode; it behaves like an alternative TX data register that is written during unused time slots. In this case, rather than transmitting data, the STD pin will be three-stated during that time slot.

PORT C

Some or all of the lines allocated from port C to the SSI must be configured as dedicated on-chip peripheral pins by setting the corresponding bits of the port C control register (PCC).

**PCC (X:\$FFE1; Read/Write)**

The port C lines are used as follows:

PC3	SC0	Bidirectional	Serial Control Line
PC4	SC1	Bidirectional	Serial Control Line
PC5	SC2	Bidirectional	Frame Sync I/O
PC6	SCK	Bidirectional	Serial Clock
PC7	SRD	Input	Receive Data
PC8	STD	Output	Transmit Data

Initializing the SSI

The recommended procedure for SSI initialization is as follows:

1. Reset the device. This can be a hardware reset, performed by driving the RESET pin low (power-on reset), or a software reset, performed by executing the RESET instruction, which resets the on-chip peripherals.
2. Program the SSI control registers CRA and CRB by writing to their locations in X-memory.
3. Configure at least one SSI pin as not general-purpose I/O by setting the corresponding control bit in the PCC register.

**HARDWARE FOR THE CODEC BOARD**

As the twin CODEC board is intended as a development tool for use in a wide variety of applications, a great deal of flexibility had to be built into the CODEC interface. This flexibility has been achieved, but at the expense of the hardware simplicity, which is possible when using the SSI.

The CODEC used for this board is the MC145503, one of the MC14550x range; the variety available from this range allows the user to select a device with as few, or as many, features as required. The MC145503 is the standard CODEC with the addition of complete access to the on-chip op-amp; it is pin compatible with the older MC14403 CODEC, which may be used equally well in the board.



CLOCK GENERATION

A clock and frame sync generator capable of supplying 2.048 MHz have been included on the board. The frame sync generator is jumper configurable, allowing either an 8-kHz or a 16-kHz frame sync for use in single and dual CODEC applications, respectively.

A further option exists with the serial communications clock and frame sync signals; they may be generated by the DSP. It is therefore possible to have split communication rates, with transmission and reception clocks being generated by the DSP (SSI asynchronous mode) and external clock, respectively, if required.

CODEC SELECTION

One of the more involved parts of the circuit is the CODEC selection circuitry. This circuitry allows either of the two CODECs to be addressed; in many applications, it would be possible to accomplish this using the serial control lines, SC0 and SC1. However, since these are multifunction lines, it is possible that some applications will require the use of them for frame synchronization or asynchronous clock inputs. Thus, the board was not restricted to using them alone for CODEC selection.

A better solution allows the option of using one of the serial control lines or one of a pair of unused port lines; the lines chosen were PB0 and PC2. These lines were chosen assuming that the user would not simultaneously require the use of all features of all three peripherals; at least one of the lines that may be used for CODEC selection should be available. PC2 is the SCI serial clock line; since many SCI applications do not use the synchronous mode, this line is almost always available. On the other hand, PB0 will always be used when the host port is required.

The CODEC select line must be synchronized to the serial data streams to prevent data corruption. Additional circuitry is not required for SC0, the serial control line used, since it is internally synchronized to the transmit frame sync signal; however, PC2 and PB0 may change asynchronously with respect to the serial data streams and thus require external synchronization. Synchronization is the function of U5B; this is a D-type that synchronizes the select line used to the rising edge of the transmit frame sync. A 74F74 is recommended for use since other types (e.g., 74HC74) will introduce an excessive propagation delay, leading to data corruption.

A second complication results in the fact that some applications require separate transmit and receive frame synchronization. This requirement has resulted in the gating of the TDE and RCE signals with the select line separately, allowing the option of splitting the frame sync signals.

POWER SUPPLY

Since the CODEC board has been specifically designed to interface to the application development system, power may be taken from this; however, -5 V must be generated locally by using a 7660-V inverter.

JUMPER OPTIONS

The following is a list of the jumpers and their functions:

- J1 Selects External Clock Generation (2.048 MHz)
- J2 Selects External Frame Sync Generation
- J3 Selects Synchronous Receive/Transmit Frame Sync
- J4 Selects Synchronous Receive/Transmit Data Clocks
- J5 Disables DSP Receive Frame Sync
- J6 Selects Operating Mode of CODECs
- J7 Disables DSP Serial Clock
- J8 Select either PC2 or PB0 for CODEC Selection
- J9 Select either SC0 or the Output of J8 for CODEC Selection
- J10 Select either 8-kHz or 16-kHz Frame Sync Generation

The jumper setting for the example software included in this document are detailed in Figure 1.

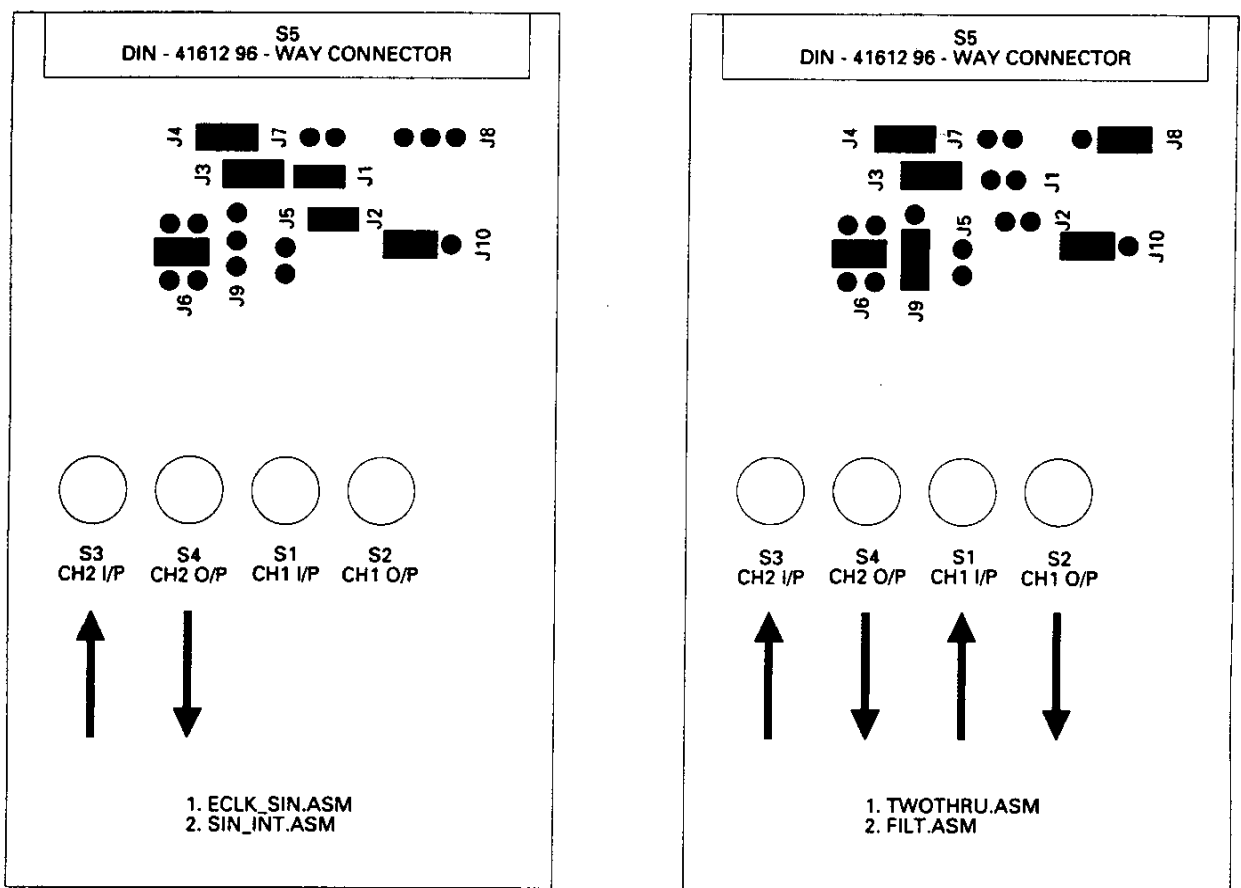
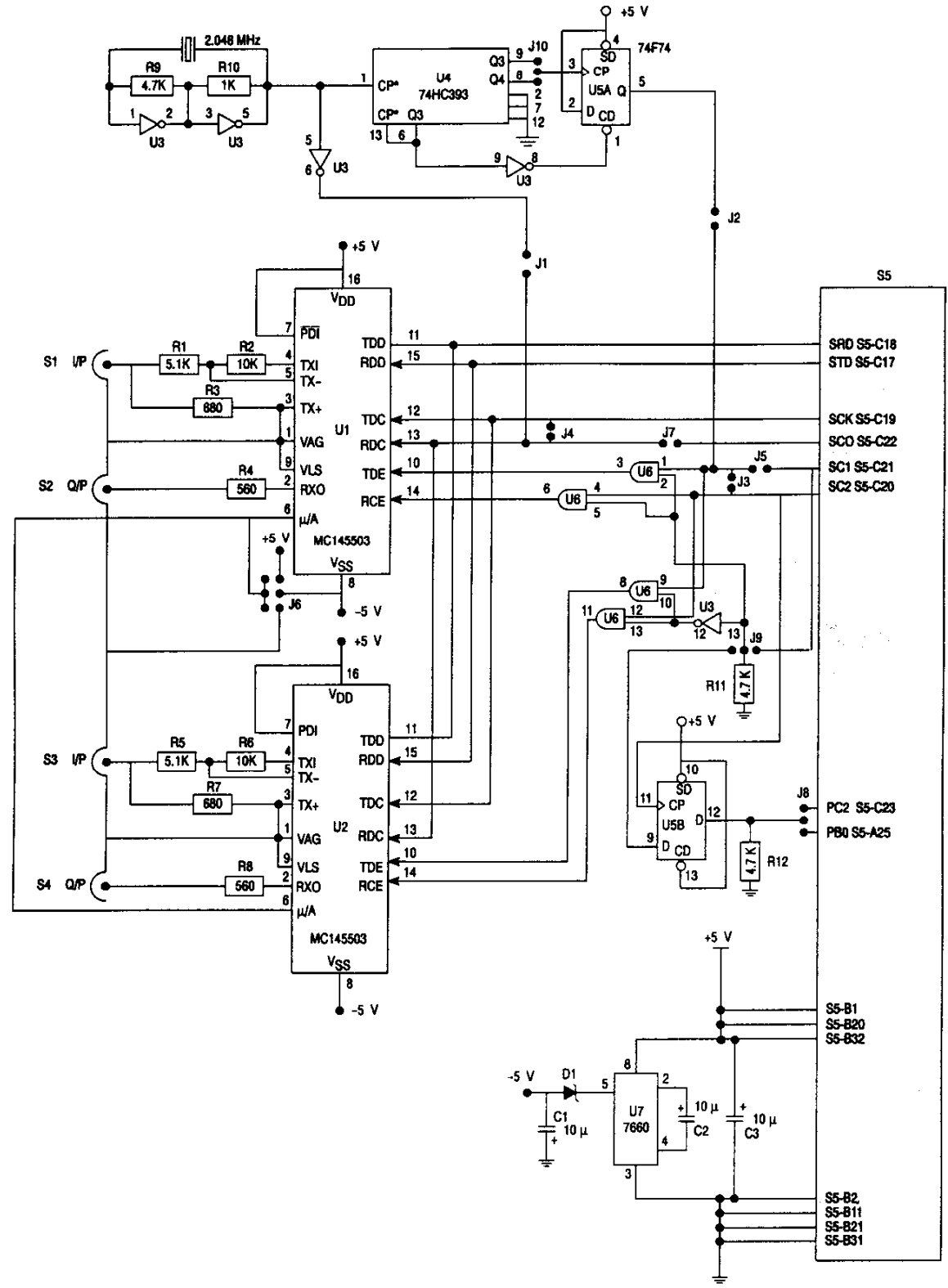

Figure 1. Configuration of the Twin CODEC Board for Example Software

Freescale Semiconductor, Inc.

APPENDIX A TWIN CODEC EXPANSION BOARD SCHEMATICS



Freescale Semiconductor, Inc.

**APPENDIX B
TWIN CODEC EXPANSION BOARD PARTS LIST**

U1,2	MC145503 PCM CODEC
U3	74HC04
U4	74HC393
U5	74F74
U6	74HC08
U7	Maxim 7660
R1,5	10 k Ω
R2,6	5.1 k Ω
R3,7	680 Ω
R4,8	560 Ω
R9,11,12	4.7 k Ω
R10	1 k Ω
C1,2,3	10 μ F tantalum
CD	0.1 μ F (decouplers)
D1	Schottky Diode
X1	2.048 MHz Crystal
S1,2,3,4	'Square Pad' BNC Connectors
S5	DIN41612 96-way connector



APPENDIX C
DEMO SOFTWARE FOR TWIN CODEC BOARD

Example 1

```
;*****
;
; FILENAME: ECLK_SIN.ASM
;
; FUNCTION: CODE INITIALISES SSI TO INTERFACE TO A SINGLE CODEC, WITH
; SYNCHRONOUS Rx/Tx SECTIONS.
;
; J1 - ON      J6 - -5V
; J2 - ON      J7 - OFF
; J3 - ON      J8 - OFF
; J4 - ON      J9 - OFF
; J5 - OFF
;
; J10 SHOULD BE SET FOR 8KHz FRAME SYNC
; (THIS IS THE POSITION AWAY FROM THE J10 LETTERING ON THE PCB)
;
;*****
include      '\dsp\demo\ioequ'      ;look for IOEQU.ASM
org          p:$40

;*****
; program code
;*****

start       move      #M_SR,r2      ; set up r2 for often-used register
            reset

; SETUP FOR EXTERNAL CLOCK

            movep     #0,x:M_CRA      ; PSR=0 , WL=0 , DC4-0=$13 , PM7-0=1
            movep     #3200,x:M_CRB ; RIE=0, TIE=0, RE, TE = 1
            movep     #1f8,x:M_PCC ; set CC(8:3) as SSI pins

;*****
; wait for transmission and reception
;*****

wait
wtde        jclr      #M_TDE,x:(r2),wtde ; wait for tde
            movep     x0,x:M_TX        ; write data to TX reg.
wrdf        jclr      #M_RDF,x:(r2),wrdf ; wait for rdf
            movep     x:M_RX,x0        ; read data from RX reg.
            jmp       wait
```

Freescale Semiconductor, Inc.



Freescale Semiconductor, Inc.

Example 2

```

;*****
;
; FILENAME: SIN_INT.ASM WRITTEN : 13/4/88
;
; FUNCTION: CODE INITIALISES SSI TO INTERFACE TO A SINGLE CODEC, WITH
; SYNCHRONOUS Rx/Tx SECTIONS. DATA TRANSFERS USE FAST INTERRUPT
;
; J1 - ON   J6 - -5V
; J2 - ON   J7 - OFF
; J3 - ON   J8 - OFF
; J4 - ON   J9 - OFF
; J5 - OFF
;

; J10 SHOULD BE SET FOR 8KHz FRAME SYNC
; (THIS IS THE POSITION AWAY FROM THE J10 LETTERING ON THE PCB)
;
;
;*****

                include    '\dsp\demo\ioequ'                ;look for IOEQU.ASM

;*****
; reset vector
;
; not normally required for the ADS; however, this will allow the user to load and
; run this file directly, without changing the PC from the ADS's default.
;
;*****

reset          org        p:$00
               jmp        start

;*****
; interrupt routines
;*****

ssi_rx         org        p:$0C
               movep     x:M_RX,a
               nop

ssi_tx         org        p:$10
               movep     a,x:M_TX
               nop

               org        p:$40

;*****
; program code
;*****

start          move       #M_SR,r2                ; set up r2 for often-used register
               reset
               movep     #$3000,x:M_IPR ; enable SSI interrupts on level 2
               movep     #0,x:M_CRA           ; PSR=0 , WL=0 , DC4-0=$13 , PM7-0=1
               movep     #$f200,x:M_CRB ; RIE=0, TIE=0, RE, TE = 1
               movep     #$1f8,x:M_PCC ; set CC(8:3) as SSI pins
               andi      #$fe,mr                ; enable interrupts
wait           jmp        wait                    ; wait for interrupt

```

Freescale Semiconductor, Inc.

Example 3

PAGE 132,66,3,3

```

;*****
;
; FILENAME: TWOTHRU.ASM WRITTEN : 13/4/88
; HISTORY : THE BEGINNING
;
; FUNCTION: CODE INITIALISES SSI TO INTERFACE TO TWO CODECS, WITH
; SYNCHRONOUS Rx/Tx SECTIONS. CODEC SELECTION IS PERFORMED
; USING PC2 OR PB0
; DATA IS READ FROM EACH CODEC, AND OUTPUT TO THE SAME CODEC.
;
; BOARD CONFIGURATION
;
; J1      OFF          J6      -5V
; J2      OFF          J7      OFF
; J3      ON           J8      END NEAREST PCB LETTERING
; J4      ON           J9      END NEAREST PCB LETTERING
; J5      OFF          J10     DON'T CARE
;
;*****
include    '\dsp\demo\ioequ'    ;look for IOEQU.ASM
org        p:$40

;*****
; program code
;*****

start      move        #M_SR,r2          ; set up r2 for often-used register
           reset

; SETUP FOR INTERNAL CLOCK

           movep       #$1301,x:M_CRA ; PSR=0 , WL=0 , DC4-0=$13 , PM7-0=1
           movep       #$3234,x:M_CRB ; RIE=0,TIE=0, RE,TE = 1
           movep       #$1f8,x:M_PCC  ; set CC(8:3) as SSI pins
           movep       #$1,x:M_PBDDR ; port B as I/O lines

;*****
; wait for transmission and reception
;*****
wait
wtde1      jclr        #M_TDE,x:(r2),wtde1 ; wait for tde
           bset        #0,x:M_PBD          ; set PB0 line for codec one
           movep       X0,x:M_TX          ; write data to TX reg.
wrdf1      jclr        #M_RDF,x:(r2),wrdf1 ; wait for rdf
           movep       x:M_RX,x0         ; read data from RX reg.

wtde2      jclr        #M_TDE,x:(r2),wtde2 ; wait for tde
           bclr        #0,x:M_PBD          ; clear PB0 line for codec two
           movep       X1,x:M_TX          ; write data to TX reg.
wrdf2      jclr        #M_RDF,x:(r2),wrdf2 ; wait for rdf
           movep       x:M_RX,X1         ; read data from RX reg.
           jmp         wait

```



Freescale Semiconductor, Inc.

Example 4

PAGE 132,66,3,3
OPT MEX

```

;*****
;
; FILENAME: FILT.ASM WRITTEN : 13/4/88
; HISTORY : THE BEGINNING
;
; FUNCTION: CODE INITIALISES SSI TO INTERFACE TO TWO CODECS, WITH
; SYNCHRONOUS Rx/Tx SECTIONS. CODEC SELECTION IS PERFORMED
; USING PC2 OR PB0
; DATA IS READ FROM EACH CODEC, AND OUTPUT TO THE SAME CODEC.
;
; BOARD CONFIGURATION
;
; J1      OFF          J6      -5V
; J2      OFF          J7      OFF
; J3      ON           J8      END NEAREST PCB LETTERING
; J4      ON           J9      END NEAREST PCB LETTERING
; J5      OFF          J10     DON'T CARE
;
;*****

include  '\dsp\demo\ioequ'      ;look for IOEQU.ASM
maclib   '\dsp\macros\filter'
maclib   '\dsp\macros\compand'

org      p:$40

;*****
; data for filters
;*****

xfilt_ad equ 0                ; address for x filter storage
n_pts_x  equ 39               ; number of points in x filter
codx_op  equ xfilt_ad+n_pts_x ; temporary store for x filter output

yfilt_ad equ 128              ; address for y filter storage
n_pts_y  equ 99               ; number of points in y filter
cody_op  equ yfilt_ad+n_pts_y ; temporary store for y filter output

;*****
; program code
;*****

start    move    #M_SR,r2      ; set up r2 for often-used register
         move    #4,omr        ; set data ROM's on for log/linear data access
         reset   ; reset on-chip peripherals in case not already done

; set up filter data

init_fir 0,4,n_pts_x,xfilt_ad ; initialise filter 1
init_fir 3,7,n_pts_y,yfilt_ad ; initialise filter 2

```



Freescale Semiconductor, Inc.

; SETUP FOR SSI INTERNAL CLOCK, SET UP SSI

```

movep    #S1,x:M_PBDDR ; port B as I/O lines
movep    #S1301,x:M_CRA ; PSR=0 , WL=0 , DC4-0=$13 ,PM7-0=1
movep    #S3234,x:M_CRB ; RIE=0,TIE=0, RE,TE = 1
movep    #S1f8,x:M_PCC ; set CC(8:3) as SSI pins

```

; transmit initial data for codecs

```

w1      jclr    #M_TDE,x:(r2),w1      ; wait for tde
        bset    #0,x:M_PBD           ; set PB0 line for codec one
        movep   #Sd5,x:M_TX          ; write first data to TX reg.
w2      jclr    #M_TDE,x:(r2),w2      ; wait for tde
        bclr    #0,x:M_PBD           ; clear PB0 line for codec two
        movep   #Sd5,x:M_TX          ; write first data to TX reg.

```

; wait for transmission and reception

```

wait
        bclr    #0,x:M_PBD           ; set PB0 line for codec one
wtde1   jclr    #M_TDE,x:(r2),wtde1   ; wait for tde
        movep   x:codx_op,x:M_TX      ; write data to TX reg.
wrdf1   jclr    #M_RDF,x:(r2),wrdf1   ; wait for rdf
        movep   x:M_RX,x0            ; read data from RX reg.
        allin   ; convert to linear data
        fir_filt r0,r4,n_pts_x ; filter using filter 1
        linal   ; back to logarithmic data for o/p
        move    a1,x:codx_op         ; store

        bset    #0,x:M_PBD           ; clear PB0 line for codec two
wtde2   jclr    #M_TDE,x:(r2),wtde2   ; wait for tde
        movep   x:cody_op,x:M_TX      ; write data to TX reg.
wrdf2   jclr    #M_RDF,x:(r2),wrdf2   ; wait for rdf
        movep   x:M_RX,x0            ; read data from RX reg.
        allin   ; convert to linear for processing
        fir_filt r3,r7,n_pts_y ; filter in filter 2
        linal   ; back to log for output
        move    a1,x:cody_op         ; store
end      jmp     wait

```

; filter coefficients
;
; FILT1 is a LPF, 3dB cutoff at 2KHz
; FILT2 is a BPF, 3dB points at 1.6KHz and 2.4KHz
;

Freescale Semiconductor, Inc.



Freescale Semiconductor, Inc.

radix 16
org y:xfilt_ad

FILT1 DC 00060B,002157,003775,FFF959,FF9A4E,FFF841,00C389,00232D
 DC FEA110,FFB51B,0257F6,007B50,FC1572,FF51F1,06A75B,00DAF9
 DC F36611,FF0606,2848B8,40CD26,2848B8,FF0606,F36611,00DAF9
 DC 06A75B,FF51F1,FC1572,007B50,0257F6,FFB51B,FEA110,00232D
 DC 00C389,FFF841,FF9A4E,FFF959,003775,002157,00060B

org y:yfilt_ad

FIR64_2 DC 000000,00016A,000000,FFFAD4,000000,0009BF,000000,FFF5BF
 DC 000000,000000,000000,0018A7,000000,FFC5F6,000000,0051D8
 DC 000000,FFBA7B,000000,000000,000000,007B83,000000,FEFC0E
 DC 000000,014DD5,000000,FEF9C5,000000,000000,000000,019ED4
 DC 000000,FCB7BA,000000,041DEB,000000,FCC911,000000,000000
 DC 000000,057118,000000,F3C20B,000000,12EAFE,000000,E8322E
 DC 000000,1998C5,000000,E8322E,000000,12EAFE,000000,F3C20B
 DC 000000,057118,000000,000000,000000,FCC911,000000,041DEB
 DC 000000,FCB7BA,000000,019ED4,000000,000000,000000,FEF9C5
 DC 000000,014DD5,000000,FEFC0E,000000,007B83,000000,000000
 DC 000000,FFBA7B,000000,0051D8,000000,FFC5F6,000000,0018A7
 DC 000000,000000,000000,FFF5BF,000000,0009BF,000000,FFFAD4
 DC 000000,00016A,000000

Freescale Semiconductor, Inc.

Example 5

```

;*****
;
; AM Modulator
;
; This example uses the twin codec board to acquire two signals.
; One is output without alteration, and also to modulate the second.
;
; BOARD CONFIGURATION
;
; J1          ON          J6          -5V
; J2          ON          J7          OFF
; J3          ON          J8          END NEAREST PCB LETTERING
; J4          ON          J9          END NEAREST PCB LETTERING
; J5          OFF         J10         END NEAREST PCB LETTERING
;
;*****

```

```

include  '\dsp\demo\ioequ'      ;look for IOEQU.ASM
maclib  '\dsp\macros\compand'

; following is the reset vector
org     p:0
jmp     start

; these are the SSI interrupt vectors. Only one pair are used
org     p:$c
jsr     interpt
jsr     interpt

; x memory reservations
org     x:
out1    ds     1           ; storage for data for codec one o/p
out2    ds     1           ; storage for data for codec two o/p
in1     ds     1           ; data received from codec 1
in2     ds     1           ; data received from codec 2

;*****
; Start of Program
; First Step - Initialisation of hardware and software
;*****

start    org     p:$40
reset    ; clear out processor
movep   #$128,x:M_CRA ; PSR=0 , WL=0 , DC4-0=$13 , PM7-0=1
movep   #$b200,x:M_CRB ; enable Tx interrupt, external clock
movep   #$1ff,x:M_PCC ; set CC(8:3) as SSI pins
move    #6,omr          ; enable data ROM's
movep   #$2300,x:M_BCR
movep   #$1,x:M_PBDDR ; port B as I/O lines
movep   #$3000,x:M_IPR ; set SSI interrupts to level 2
move    #2,sr          ; and enable interrupts

runtime jmp     runtime ; and continue waiting for more data

```

```

;*****
; this is the interrupt routine
;*****

interp      jset      #0,x:M_PBD,proc      ; if PBD line set, do frame processing
            bset      #0,x:M_PBD          ; if not, set PBD line for codec one
            movep    x:out1,X:M_TX        ; and write output data to codec one
            movep    X:M_RX,x:in2         ; read input data read from codec two
            rti

proc        bclr      #0,x:M_PBD          ; if not, clear PBD line for codec two
            movep    x:out2,X:M_TX        ; and write output data to codec two
            movep    X:M_RX,x:in1         ; read input data read from codec one
            andi     #$fc,mr              ; re-enable interrupts to allow I/O during processing
crdd        jsr       process             ; process data
            rti

```

```

;*****
; This routine performs signal processing tasks on the data
; As an example, one channel is used to modulate the other
;*****

```

```

process     move      x:in1,a              ; read sample from channel 1
            move     a,x:out1             ; output to same channel
            allin    ; convert channel1 data to linear
            move     a1,y0                ; and transfer for multiply
            move     x:in2,a              ; read sample from channel 2
            allin    ; convert channel 2 to linear
            move     a1,x0                ; transfer back for multiply

            mpy      x0,y0,a              ; perform multiply for AM modulation
            linal    ; convert result to log format
            move     a1,x:out2            ; output modulated result to channel 2
            rts

```

APPENDIX D EXAMPLE FILTER DESCRIPTION

FILTER IMPLEMENTATION TECHNIQUES

The filters used as examples in the demo software are implemented around the following two software macros. All are FIR filters, with different numbers of taps, and were designed using a proprietary digital filter CAD system.

The macros were implemented to allow the rapid creation of different forms of FIR filter. They cover both initialization and execution of the filter.

The first macro, INIT_FIR, is passed various parameters indicating to the assembler which register to use for the filter, how many taps are in the filter, and what memory area to use; it then initializes the DSP to perform this filter. Note that this generates filters with symmetrical memory usage; i.e., if the filter uses the first 100 locations of X-memory, it will also use the first 100 locations of Y-memory.

The second macro, FIR_FILT, performs one pass of the FIR filter algorithm. It must be passed the register pair used for data and coefficient access.

MACRO — INIT_FIR

```

;*****
; FIR Filter Initialisation macro
;
; Calling Procedure      :   init_fir  coeff,data,points,address
;
; Parameters            :   coeff  - number of coefficient address register set
;                          :         in the range 0-7 (ie R0/N0/M0 - R7/N7/M7)
;                          :   data   - number of data address register set
;                          :         in the range 0-7 (ie R0/N0/M0 - R7/N7/M7)
;                          :   points - number of points in filter
;                          :   address - X/Y memory area to be used for data
;                          :         and coefficients
;
; Comments              :   coeff and data should not be in the same address register
;                          :         group; ie one may be in group 0-3, the other group 4-7
;                          :   This initialisation routine sets up the filter to use the same
;                          :         locations in X & Y memory.
;*****

init_fir      MACRO          COEFF,DATA,POINTS,ADDRESS      move
#?ADDRESS,r\COEFF
              move          #?ADDRESS,r\DATA
              move          #?POINTS-1,m\COEFF
              move          #?POINTS-1,m\DATA
              ENDM

```

MACRO — FIR_FILT

```

;*****
; FIR filter macro ; ; input linear data in a1 ; output result in a1 ;
;*****

fir_filt      MACRO          COEFF,DATA
              move          a1,x0
              clr           a                x0,x:(DATA)+   y:(COEFF)+,y0
              rep          #n_pts_1-1
              mac          x0,y0,a         x:(DATA)+,x0   y:(COEFF)+,y0      macr
x0,y0,a      (DATA)-
ENDM

```

Filter 1

The first filter was implemented using the FDAS filter design package, available from Momentum Data Systems. The filter was designed using the Parks-MacLellan design methodology; the initial specification for the filter is as follows:

Sample Rate	8 kHz
Filter Type	LPF
Upper Limit of Passband	1.4 kHz
Lower Limit of Stopband	2.1 kHz
Passband Ripple	-0.1 dB
Stopband Ripple	-78 dB
Number of Taps	39

This gives the filter of Figure D-1(a); this transfer function has been evaluated using extended floating-point arithmetic and is thus the closest achievable theoretically ideal filter. However, few DSPs will work to this type of accuracy; the coefficients must be truncated to fit in the word length of the processor used. In the case of the DSP56000, the word length is 24 bits; Figure D-1(b) is the realizable transfer function when the coefficients are quantized for this word length.

As can be seen, truncating the coefficients to 24 bits has had no serious effect on the filter's transfer function. This is not always the case; for example, truncating the coefficients to 16 bits significantly alters the stopband characteristics of the filter.

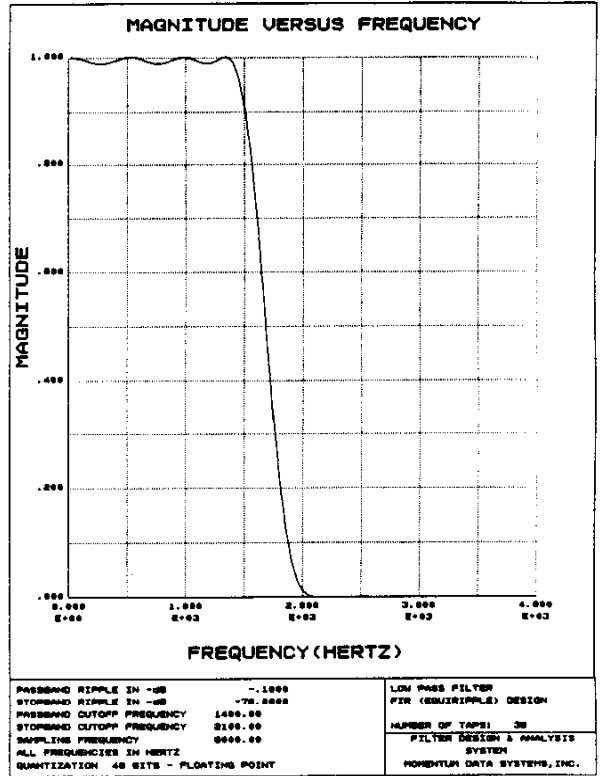
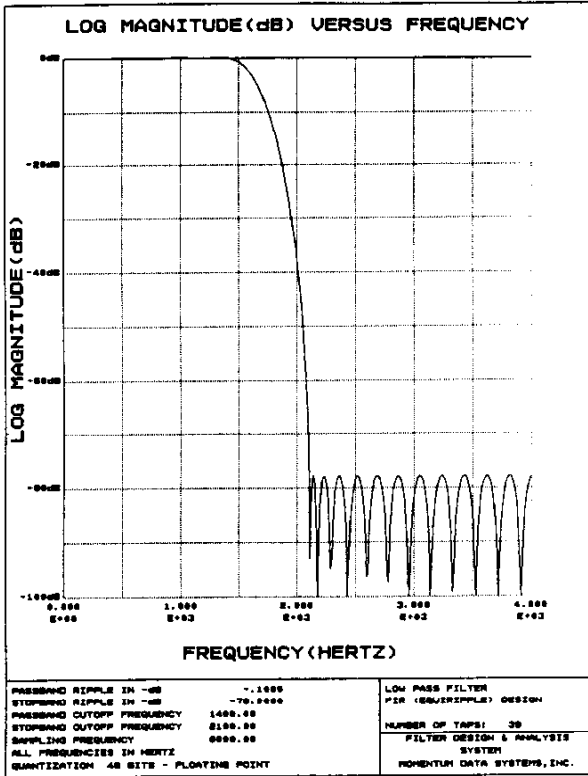

Figure D-1(a). Theoretical Log and Magnitude Plots Lowpass Filter

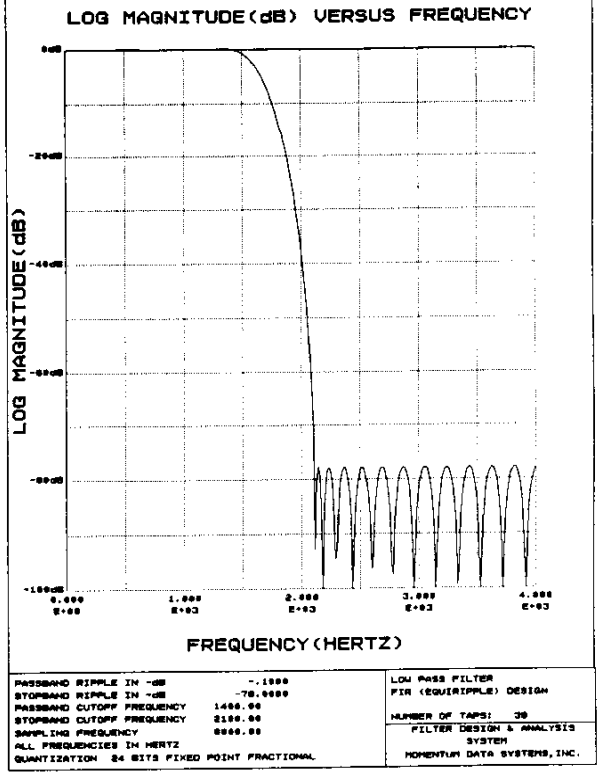
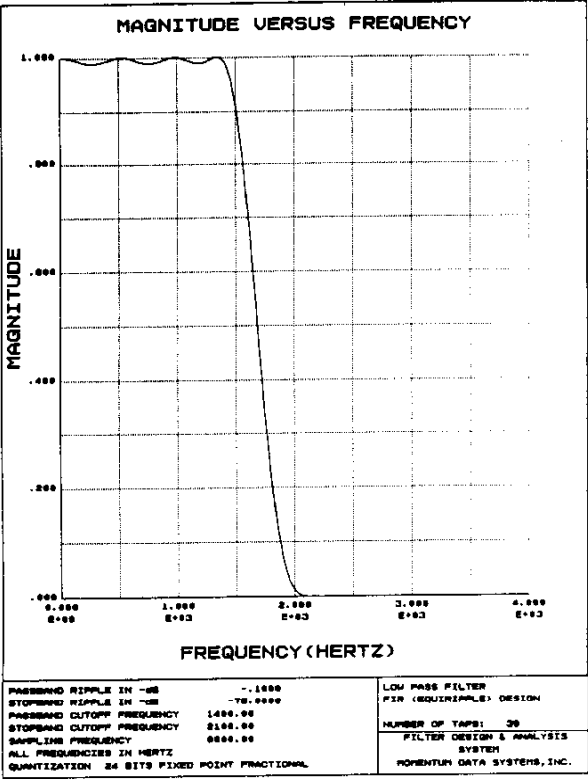

Figure D-1(b). Realizable Log and Magnitude Plots Lowpass Filter

Filter 2

The second filter was again implemented using the FDAS filter design package, available from Momentum Data Systems. The filter was again designed using the Parks Maclellan design methodology; the initial specification for the filter is as follows:

Sample Rate	8 kHz
Filter Type	BPF
Upper Limit of Passband	2.2 kHz
Lower Limit of Passband	1.8 kHz
Upper Limit of Stopband	1.4 kHz
Lower Limit of Stopband	2.6 kHz
Passband Ripple	-0.1 dB
Stopband Ripple	-78 dB
Number of Taps	69

This gives the filter of Figure D-2; the 24-bit version of the filter.

It should be noted that when using a CODEC, only approximately 78 dB of resolution is available. These filters were designed with that fact in mind; the DSP56000 will support filters with cutoffs of -144 dB. In this application, such a filter would be excessively powerful.

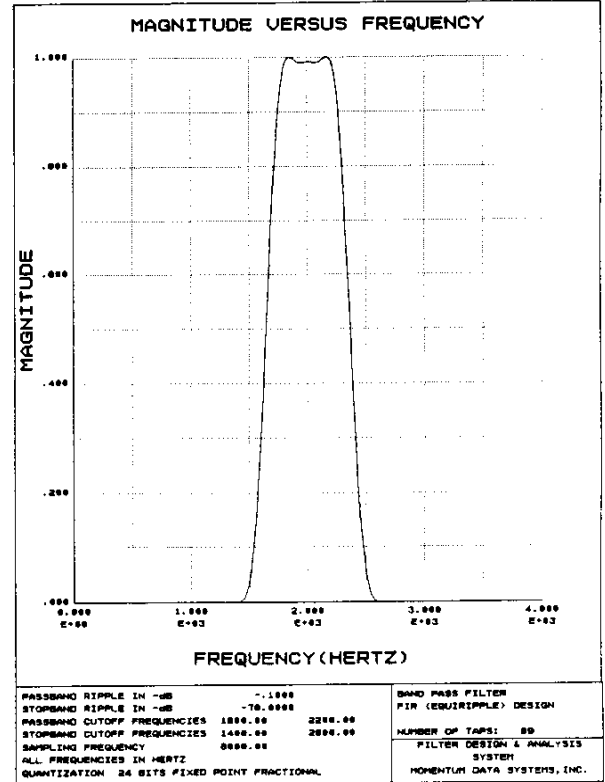
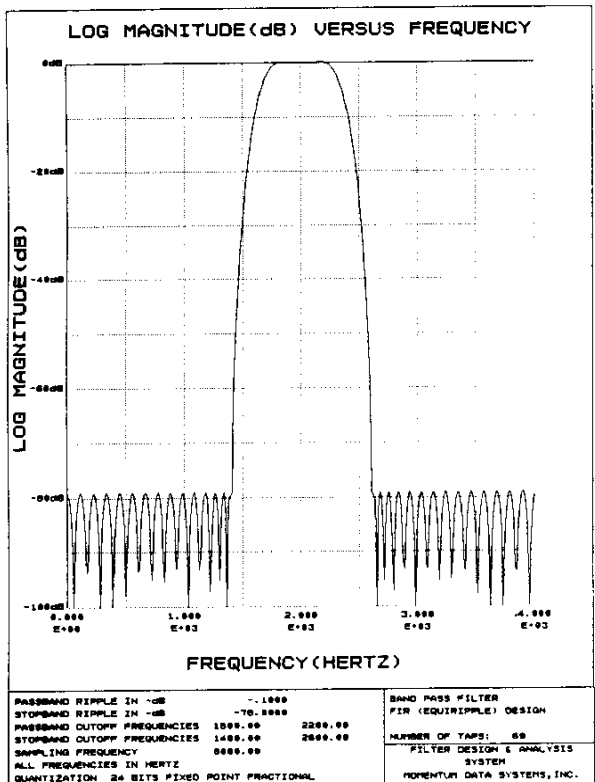

Figure D-2. Realizable Log and Magnitude Plots Bandpass Filter

Freescale Semiconductor, Inc.

APPENDIX E LOG/LIN CONVERSION ROUTINES

```

;
; This program originally available on the Motorola DSP bulletin board.
; It is provided under a DISCLAIMER OF WARRANTY available from
; Motorola DSP Operation, 6501 Wm. Cannon Drive W., Austin, Tx., 78735.
;
; Linear PCM to Companded CODEC Data Conversion Macros
;
; Last Update 20 Apr 87  Version 1.0
;
linlog ident 1,0
;
; These macros convert 13 bit, linear fractional data into 8 bit companded
; data suitable for transmission to CODEC D/A converters used in
; telecommunications applications. Four companded formats are
; supported for the Motorola MC14400 CODEC series and similar devices.
;
; Macro Calls:      linsm - linear to sign magnitude conversion
;                   with mu-law companding.
;                   linmu - linear to mu-law companded conversion
;                   without zero code suppression.
;                   lind3d4 - linear to mu-law companded conversion
;                   with D3/D4 format zero code suppression.
;                   linal - linear to a-law companded conversion
;                   with CCITT (G7.12) format.
;
;                   No macro arguments are required. However, these
;                   macros assume that the scaling modes are off
;                   (S1=0, S0=0).
;
; Input data is a 56 bit number in accumulator a. Although any 56 bit
; number may be used, the 13 bit linear fraction is assumed to be in
; the most significant bits of a1. Values outside this fractional range
; are automatically converted to a maximum positive or negative companded
; value (dynamic range limiting).
;
; Output data is in the 8 most significant bits of a1. The 16 LSB's
; of a1 are zero.
;
; _____
; | Sign |   Chord Number   |   Step Number   |
; | Bit |               |                 |
; | 23  | 22  21  20  | 19  18  17  16  |
;
; Alters Data ALU Registers
;   x1   x0
;   a2   a1   a0   a
;   b2   b1   b0   b
;
; Alters Address Registers
;   r0
;
; Alters Program Control Registers
;   pc   sr
;
; Uses 0 locations on System Stack
;
; Latest Revision - April 15, 1987
; Tested and verified - April 20, 1987
;

```

```

; linsm - linear to sign magnitude conversion
;
linsm macro
  _bias equ    $008400          ;absolute bias = 33
;
  tfr   a,b    a,a              ;save input sign, limit input data
  abs   a      #_bias,x0       ;form input magnitude, get bias
  add   x0,a   #7,r0           ;add bias to magnitude, get chord bar
  move  a      a,a              ;limit again
  rep   #7                      ;find chord number by normalizing
  norm  r0,a   ; biased magnitude to get step number
  asl   a                      ;isolate step number
  asl   a      b,b              ;limit input again
  neg   b      r0,a2           ;invert sign bit, get chord number
  asr   a                      ;combine chord and step
  asr   a
  asr   a
  asl   b                      ;get sign bit
  ror   a      #<$ff,x0       ;combine sign, chord and step
  and   x0,a   ;clear 16 LSB's
  endm

;
; linmu - linear to mu-law conversion
;
linmu macro
  _bias equ    $008400          ;absolute bias = 33
;
  tfr   a,b    a,a              ;save input sign, limit input data
  abs   a      #_bias,x0       ;form input magnitude, get bias
  add   x0,a   #7,r0           ;add bias to magnitude, get chord bar
  move  a      a,a              ;limit again
  rep   #7                      ;find chord number by normalizing
  norm  r0,a   ; biased magnitude to get step number
  asl   a                      ;isolate step number
  asl   a      b,b              ;limit input again
  neg   b      r0,a2           ;invert sign bit, get chord number
  asr   a                      ;combine chord and step
  asr   a
  asr   a
  not   a                      ;invert 7 LSB's for mu-law
  asl   b                      ;get sign bit
  ror   a      #<$ff,x0       ;combine sign, chord and step
  and   x0,a   ;clear 16 LSB's
  endm

;
; lind3d4 - linear to mu-law conversion with zero code suppression
;
lind3d4 macro
  _bias equ    $008400          ;absolute bias = 33
;
  tfr   a,b    a,a              ;save input sign, limit input data
  abs   a      #_bias,x0       ;form input magnitude, get bias
  add   x0,a   #7,r0           ;add bias to magnitude, get chord bar
  move  a      a,a              ;limit again
  rep   #7                      ;find chord number by normalizing
  norm  r0,a   ; biased magnitude to get step number
  asl   a                      ;isolate step number
  asl   a      b,b              ;limit input again
  neg   b      r0,a2           ;invert sign bit, get chord number
  asr   a                      ;combine chord and step

```

Freescale Semiconductor, Inc.



Freescale Semiconductor, Inc.

```

asr    a
asr    a
not    a           ;invert 7 LSB's for mu-law
asl    b           ;get sign bit
ror    a           #<$ff,x0 ;combine sign, chord and step
and    x0,a       #<$02,x0 ;clear 16 LSB's
teq    x0,a       ;suppress zero code
endm

;
; linal - linear to a-law conversion
;
linal macro
tfr    a,b       a,a           ;save input sign, limit input data
move   #1,a0     ;force to non-zero value
abs    a         #7,r0        ;form input magnitude, get chord bar
move   a,a       ;limit again
rep    #6        ;find chord number by normalizing
norm   r0,a      ;magnitude to get step number
jnr    <_ok      ;jump if normalized
move   (r0)-     ;adjust for chord zero
_ok    asl    a           ;isolate step number
      asl    a         b,b     ;limit input again
      neg    b         r0,a2   ;invert sign bit, get chord number
      asr    a           ;combine chord and step
      asr    a
      asr    a
      asl    b           ;get sign bit
ror    a         #<$ff,x0     ;combine sign, chord and step
and    x0,a       #<$55,x0   ;clear 16 LSB's
eor    x0,a       ;invert odd bits for a-law
endm

```

```

;
; This program originally available on the Motorola DSP bulletin board.
; It is provided under a DISCLAIMER OF WARRANTY available from
; Motorola DSP Operation, 6501 Wm. Cannon Drive W., Austin, Tx., 78735.
;

```

```

; Companded CODEC to Linear PCM Data Conversion Macros
;

```

```

; Last Update 20 Apr 87  Version 1.0
;

```

```

loglin ident 1,0
;

```

```

; These macros convert 8 bit companded data received from CODEC A/D
; converters used in telecommunications applications to 13 bit, linear
; fractional data. The internal mu/a-law lookup tables in the DSP56001
; X data ROM are used to minimize execution time. Three companded
; formats are supported for the Motorola MC14400 CODEC series and
; similar devices.
;

```

```

; Macro Calls:
;          smlin - sign magnitude to linear conversion
;                  with mu-law companding.
;          mulin - mu-law companded to linear conversion.
;          allin - a-law companded to linear conversion
;                  with CCITT (G7.12) format.
;

```

```

;          No macro arguments are required. However, these
;          macros assume that the scaling modes are off
;          (S1=0, S0=0).
;

```

Freescale Semiconductor, Inc.

```

; Input data is in the 8 most significant bits of a1. The remaining
; bits of a are ignored.
;
; _____
; | Sign |   Chord Number   |   Step Number   |
; | Bit  |   |   |   |   |   |   |   |   |
; |__23__|__22__|__21__|__20__|__19__|__18__|__17__|__16__|
;
; Output data is in the 56 bit accumulator a. The linear fraction is
; in the 13 most significant bits of a1 and the 11 least significant
; bits are zero.
;
; Alters Data ALU Registers
;   x1   x0
;   a2   a1   a0   a
;   b2   b1   b0   b
;
; Alters Address Registers
;   r0
;
; Alters Program Control Registers
;   pc   sr
;
; Uses 0 locations on System Stack
;
; Latest Revision - April 15, 1987
; Tested and verified - April 20, 1987
;
; smlin - sign magnitude to linear conversion
;
smlin macro
  _shift equ    $80           ;shift constant
  _mutable equ   $100         ;base address of mu-law table
;
    not    a      a1,b        ;invert input bits, save input
    lsl   a      #>_shift,x0  ;shift out sign bit, get shift constant
    lsr   a      #_mutable,x1 ;shift in zero, get table base
    tfr   x1,a    a1,x1       ;swap table base and offset
    mac   x1,x0,a          ;shift offset down and add to base
    move  a,r0            ;move to address register
    nop
    lsl   b      x:(r0),a     ;c=sign bit, lookup linear data
    neg   a      a,b         ;a=negative result, b=positive result
    tcs   b,a            ;if pos sign, correct result
    endm
;
; mulin - mu-law to linear conversion
;
mulin macro
  _shift equ    $80           ;shift constant
  _mutable equ   $100         ;base address of mu-law table
;
    move  a1,b            ;save input
    lsl   a      #>_shift,x0  ;shift out sign bit, get shift constant
    lsr   a      #_mutable,x1 ;shift in zero, get table base
    tfr   x1,a    a1,x1       ;swap table base and offset
    mac   x1,x0,a          ;shift offset down and add to base
    move  a,r0            ;move to address register
    nop
    lsl   b      x:(r0),a     ;c=sign bit, lookup linear data

```

```

neg    a    a,b    ;a=negative result, b=positive result
tcs    b,a    ;if pos sign, correct result
endm

;
; allin - a-law to linear conversion
;
allin macro
_shift equ    $80    ;shift constant
_atable equ    $180    ;base address of a-law table
;
    move        a1,b    ;save input
    lsl        a    #>_shift,x0    ;shift out sign bit, get shift constant
    lsr        a    #_atable,x1    ;shift in zero, get table base
    tfr        x1,a    a1,x1    ;swap table base and offset
    mac        x1,x0,a    ;shift offset down and add to base
    move        a,r0    ;move to address register
    nop
    lsl        b    x:(r0),a    ;c=sign bit, lookup linear data
    neg        a    a,b    ;a=negative result, b=positive result
    tcs        b,a    ;if positive sign, correct result
endm

```

APPENDIX F
TWIN CODEC EXPANSION BOARD PCB ARTWORK

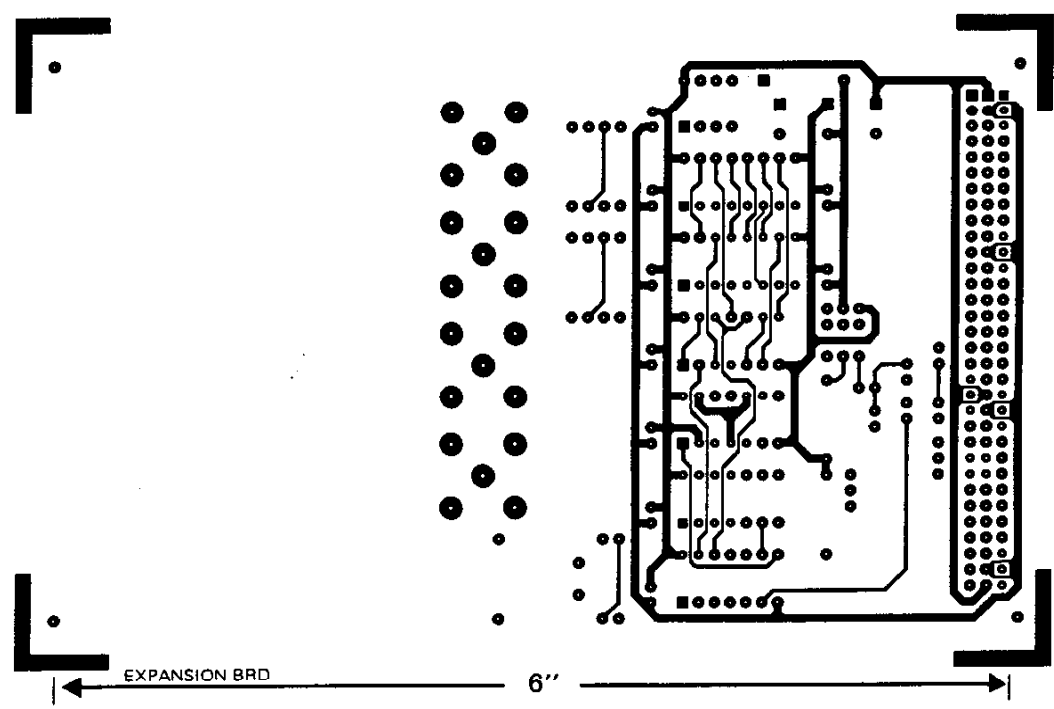

Figure F-1(a). PCB Artwork
Component Side

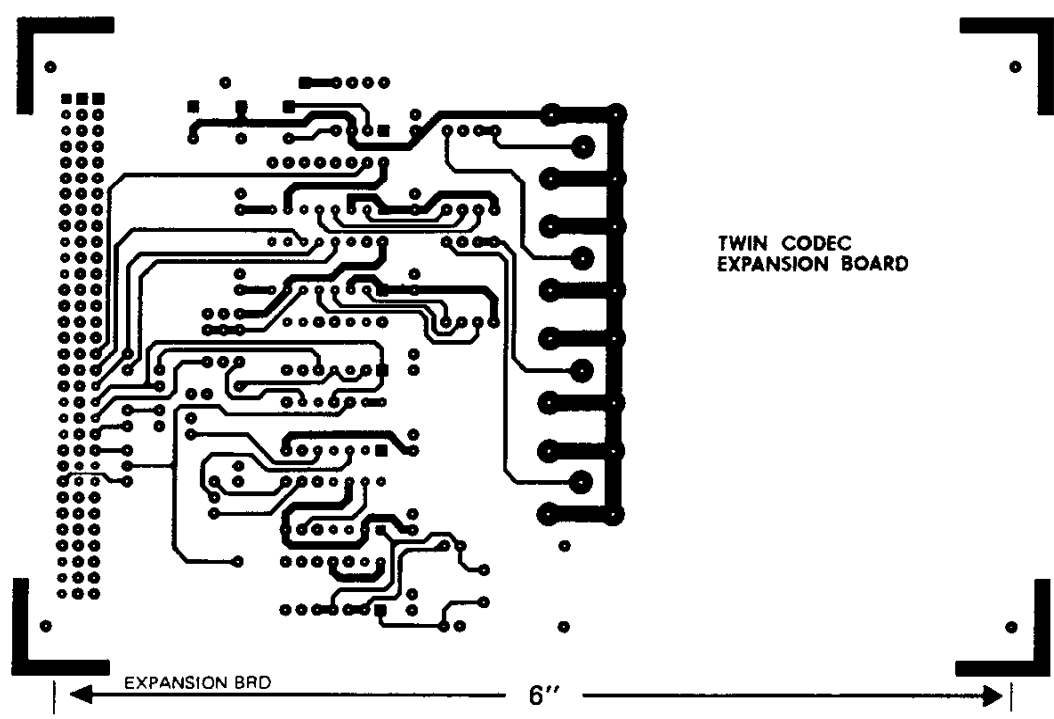

Figure F-1(b). PCB Artwork
Solder Side

Freescale Semiconductor, Inc.

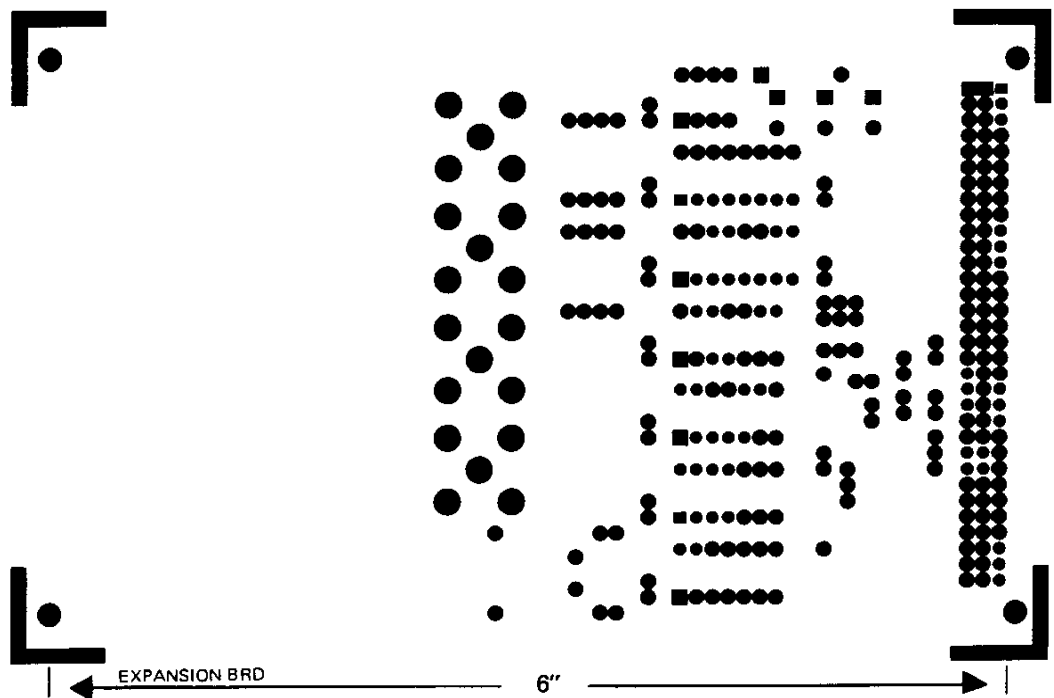

Figure F-1(c). Solder Resist Mask

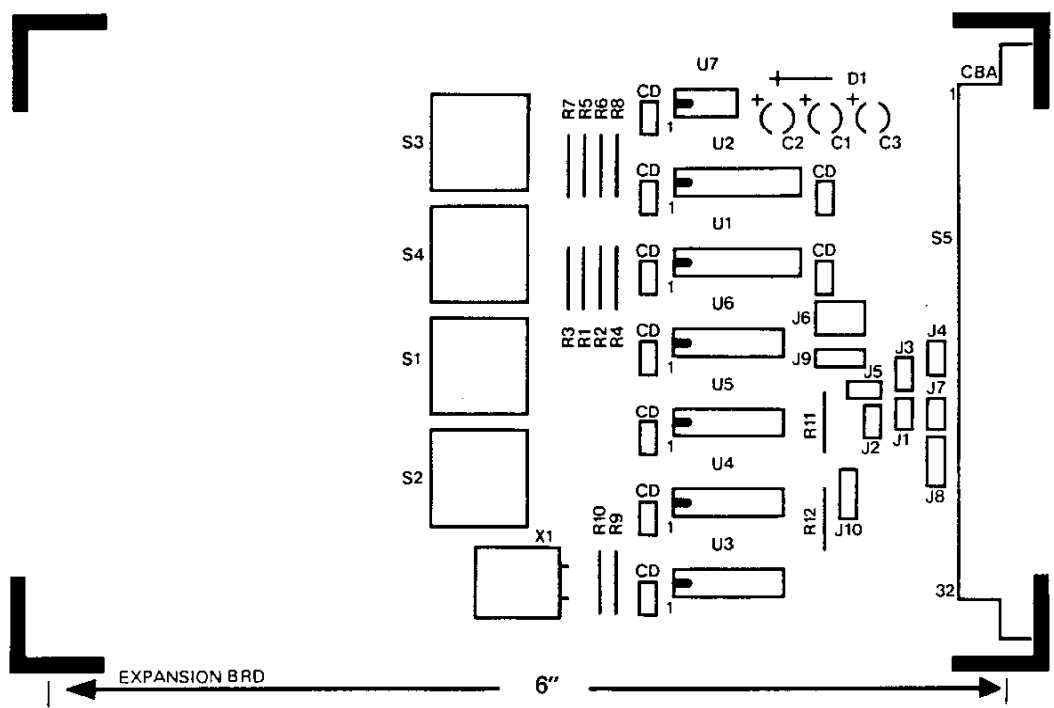
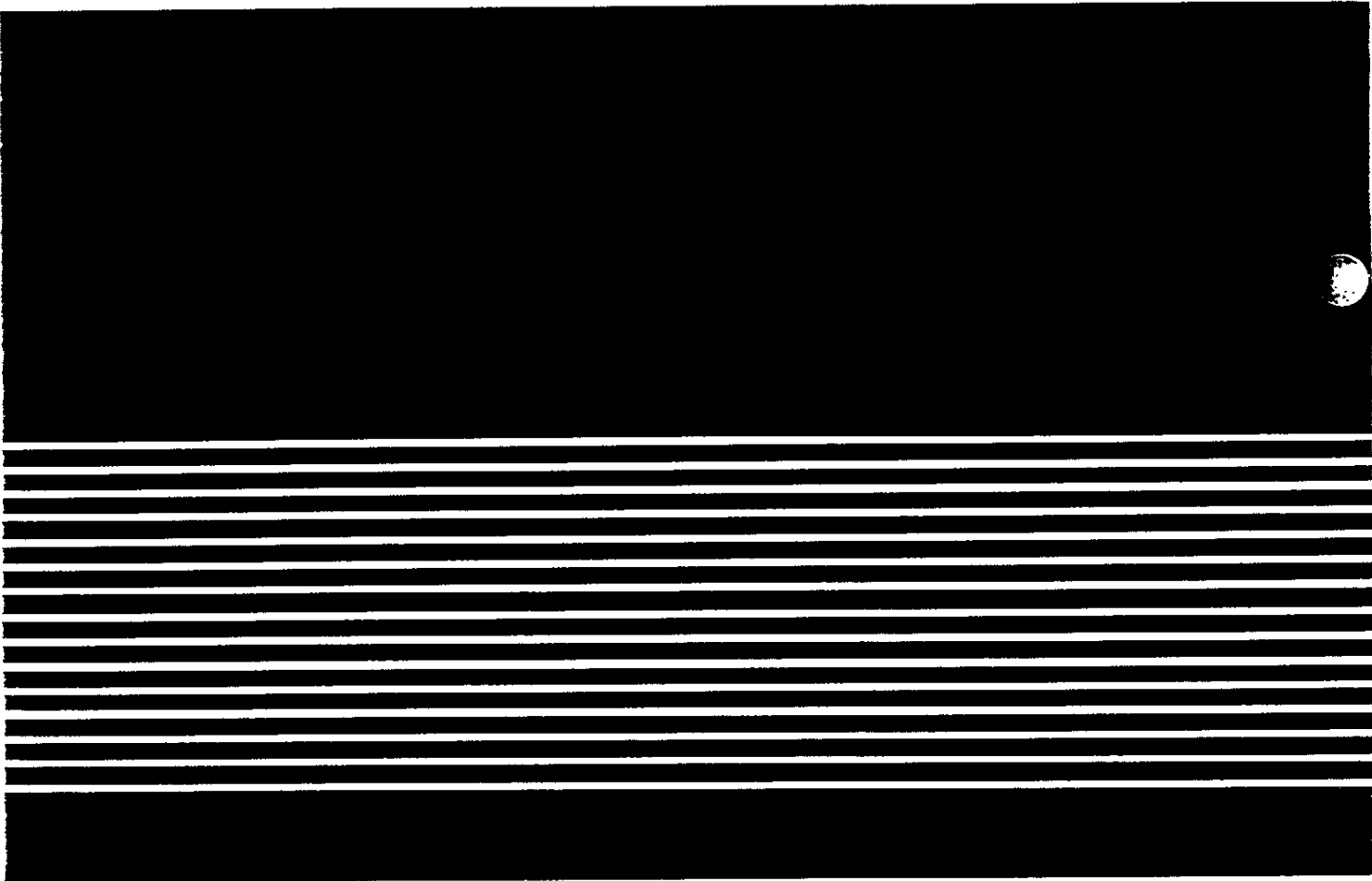

Figure F-1(d). Screen Printing



Freescale Semiconductor, Inc.



Literature Distribution Centers:

USA: Motorola Literature Distribution; P.O. Box 20912; Phoenix, Arizona 85036.

EUROPE: Motorola Ltd.; European Literature Centre; 88 Tanners Drive, Blakelands, Milton Keynes, MK14 5BP, England.

JAPAN: Nippon Motorola Ltd.; 4-32-1, Nishi-Gotanda, Shinagawa-ku, Tokyo 141 Japan.

ASIA-PACIFIC: Motorola Semiconductors H.K. Ltd.; Silicon Harbour Center, No. 2 Dai King Street, Tai Po Industrial Estate, Tai Po, N.T., Hong Kong.



MOTOROLA

1ATX30137-2 PRINTED IN USA 4/15 IMPERIAL LITHO 12898 2,000 DSP YGAVAA

APR12/D



**For More Information On This Product,
Go to: www.freescale.com**