

JN-AN-1035

Calculating 802-15-4 Data Rates

Rev. 1.2 — 19 May 2016

Application Note

Document information

| Info | Content |
|-----------------|--|
| Keywords | JN5161, JN5164, JN5168, JN5169, JN5174, JN5178, JN5179 |
| Abstract | Application Note for JN516x & JN517x platform design. |



Revision history

| Rev | Date | Description |
|-----|----------|--|
| 1.0 | 2013 | 1 st release |
| 1.1 | Nov 2013 | Updated for JN5161/4/8 wireless microcontrollers |
| 1.2 | May 2016 | Update for JN517x products |

Contact information

For more information, please visit: <http://www.nxp.com>

1. Introduction

This Application Note describes how to calculate the effective and actual data rates of an IEEE 802.15.4 wireless network containing nodes that employ the NXP JN51xx wireless microcontrollers (e.g. JN5168, JN5169, JN5174, JN5178 and JN5179). The 802.15.4 data frame structure and channel access protocol overhead are described first. Then an example calculation for transferring 1 MB of data is given.

2. Application Overview

The IEEE 802.15.4 standard for Low-Rate Wireless Personal Area Networks (LR-WPANs) supports a maximum over-the-air data rate of 250 kbps for the 2400-MHz band. In practice, the effective data rate is somewhat lower due to the protocol built into the frame structure. Various mechanisms are also employed to ensure robust data transmission. These include channel access algorithms, data verification and frame acknowledgement. The data frame structure and associated protocol overhead are described, and used to determine the maximum data payload and packet transmission time. The channel access and frame acknowledge times are also calculated. An example actual data rate calculation is given for a non-beacon enabled network using unslotted CSMA-CA (with acknowledgements) and a transmission time calculated for 1 MB of data.



Note: The effective handling of the 802.15.4 protocol is critical in order to maintain the maximum data rate of the system. Depending on the system architecture, the processor overhead imposed by the user application can often compromise data rates. The JN51xx devices incorporate a hardware implemented Base Band Controller. This handles the PHY access protocol such as Clear Channel Assessment, auto-acknowledge, packet retries and CRC Checking *without* the need for processor intervention. The JN51xx devices also provide a SPI slave (up to 8 Mbps), and also support transfer rates of up to 1 Mbps on the UART.

3. Channel Access Timing

Non-beacon enabled IEEE 802.15.4 networks use an unslotted CSMA-CA channel access mechanism. This algorithm is shown in the Appendix, Figure 5. Each time a device needs to transmit, it waits for a random number of unit back-off periods in the range $\{0, 2^{BE} - 1\}$ before performing the Clear Channel Assessment (CCA).

- If the channel is found to be idle, the device transmits.
- If the channel is found to be busy, the device waits another random period before trying to access the channel again.

Initially, the back-off exponent BE is set to $macMinBE$. Using the default value of 3 for $macMinBE$ and assuming the channel is found to be free, the worst-case channel access time can be calculated as:

$$\begin{aligned}InitialbackoffPeriod + CCA &= (2^3 - 1) \times aUnitBackoffPeriod + CCA \\ &= 7 \times 320 \mu\text{s} + 128 \mu\text{s} \\ &= \mathbf{2.368 \text{ ms}}\end{aligned}$$

The CCA detection time is defined as 8 symbol periods.

$aUnitBackoffPeriod$ is defined as 20 symbol periods.

1 symbol period is equal to 16 μs .



Note: If the $macMinBE$ value is set to 0, collision avoidance is disabled during the first iteration of the algorithm. In this case, the channel access timing is defined by the minimum Inter-Frame Separation (IFS) constants $aMinSIFSPeriod$ and $aMinLIFSPeriod$ [1].

4. Data Frame transmission

4.1 Maximum Data Payload

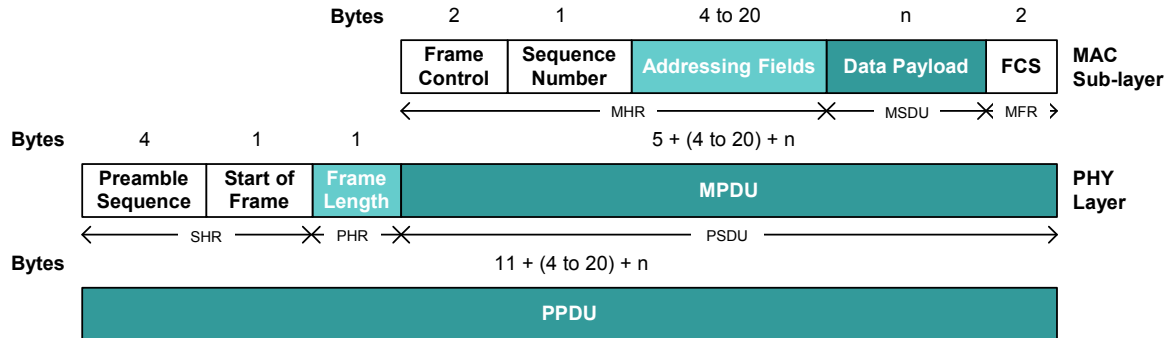

Figure 1: Schematic View of Data Frame

The IEEE 802.15.4 standard [1] specifies the maximum number of Bytes that can be transmitted in the MAC data payload as 102 Bytes:

$$aMaxMACFrameSize (MSDU) = aMaxPHYPacketSize (MPDU) - aMaxFrameOverhead$$

$$aMaxFrameOverhead = 25$$

$$aMaxPHYPacketSize = 127 \text{ (max PSDU size)}$$

The IEEE 802.15.4 standard defines *aMaxMACFrameSize* using the maximum frame overhead regardless of the actual frame overhead size. The IEEE 802.15.4 (2006) standard, supported by the JN51xx devices, allows the maximum data payload to be larger when fewer addressing fields are being used. Using short addressing (16-bit source and destination addresses), the frame overhead is reduced to 13 Bytes, leaving a data payload of **114 Bytes** (see Figure 2).

| | | | | | | | |
|-------------------|-----------------|--------------------|---------------------|---------------|----------------|---------------|----------|
| Bytes: 2 | 1 | 0/2 | 0/2/8 | 0/2 | 0/2/8 | variable | 2 |
| Frame control | Sequence number | Destination PAN ID | Destination address | Source PAN ID | Source address | Frame payload | FCS |
| Addressing fields | | | | | | | |
| MHR | | | | | | MAC payload | MFR |

Figure 2: MAC Protocol Data Unit (MPDU)

$$\text{Frame Overhead (Bytes)} = \text{Frame ctrl (2 Bytes)} + \text{SeqNumber (1 Byte)} + \text{DestPAN ID (2 Bytes)} + \text{Destination add (2 Bytes)} + \text{Source PAN ID (2 Bytes)} + \text{Source add. (2 Bytes)} + \text{FCS (2 Bytes)} = 13 \text{ Bytes}$$



Note: For the Star network topology, it is possible to specify only source addressing fields, increasing the maximum data payload to **118 Bytes**. In this situation, the frame is accepted only if the device is a PAN Coordinator and the source PAN identifier matches that of the PAN Coordinator.

4.2 Data Frame Transfer Time

Adding the 6-Byte packet overhead (Preamble and Start of Frame Delimiter [SHR], and Frame Length [PHR]) to the MAC Protocol Data Unit (MPDU), and given a fundamental data rate into the modem of 250 kbps, the frame transfer time is calculated as:

$$\frac{(aMaxPHYPacketSize + SHR + PHR) \times 8}{250 \times 10^3} = \frac{(127 + 5 + 1) \times 8}{250 \times 10^3} = 4.256ms$$

(For a maximum data payload of 114 Bytes with 16-bit source and destination addresses)

5. Acknowledgement frame Transmission

5.1 Timing

An acknowledgement frame consists of 11 Bytes and is shown in Figure 3. Given a fundamental data rate into the modem of 250 kbps, transmission takes **0.352 ms**. The transmission of an acknowledgement does not use CSMA/CA.

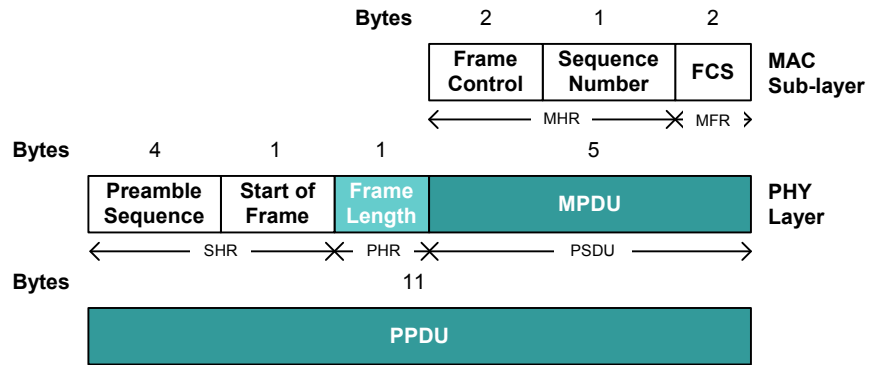

Figure 3: Schematic View of Acknowledgement Frame

The transmission of an acknowledgement frame (in a non-beacon enabled network) commences *aTurnaroundTime* symbols after the reception of the data frame, where *aTurnaroundTime* is equal to **192 μs**. This allows the device enough time to switch between transmit and receive, or vice versa. The timing for an acknowledged transmission is shown in Figure 4 below.

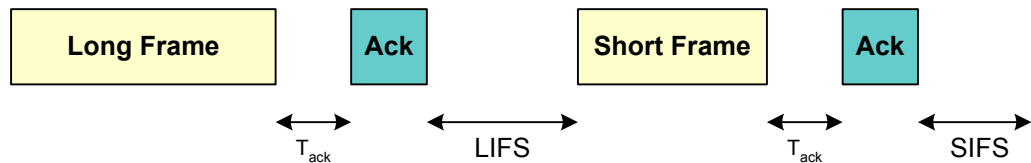

Figure 4: Acknowledged Transmission Timing

1. (LIFS = Long Inter-Frame Spacing, SIFS = Short Inter-Frame Spacing)

To allow the received data to be processed, the acknowledgement frame can be followed by a minimum inter frame separation period (IFS). The length of the IFS period is dependent on the frame size. Frames (MPDUs) of up to 18 Bytes in length must be followed by a SIFS period of at least 12 symbol periods. Frames with lengths greater than 18 Bytes must be followed by a LIFS of at least 40 symbol periods. In real cases, this defined minimum IFS delay is usually absorbed by the CSMA-CA channel access timing. It means for energy saving reason, transmitter IFS is overlapping CSMA-CA and it results in a minimum IFS equals to the back-off time.

5.2 Retry Timing

In practice, it is unlikely that a 0% PER will be achieved. The transmitting node will wait *macAckWaitDuration* symbol periods for an acknowledgement before it attempts a retry, where *macAckWaitDuration* is equal to 54 symbol periods (**0.864 ms**).

6. Effective Data Rate

Here is done the average throughput calculation for a point to point transmission from transmitter perspective. So from the information detailed above, an effective data rate can be calculated based on the following assumptions:

- Non-beacon enabled network
- CSMA/CA algorithm never finds that the channel is busy
- Includes subsequent reception of associated acknowledgment
- No retries are required
- Maximum data payload is 114 Bytes

The calculation is as follows:

| | |
|------------------------------|--|
| CSMA/CA (data frame) | 2.368 ms (default random back-off exponent of 3) |
| Data frame transmission | 4.256 ms |
| Turnaround time (Tx to Ack) | 0.192 ms |
| Acknowledgement transmission | 0.352 ms |

| | |
|-------|----------|
| Total | 7.168 ms |
|-------|----------|

Effective data rate = (DataPayloadTime / Total time) x BaudRate
 = ((114 x 8)/250)/7.168 x 250
 = (114 x 8) / (7.168) = **127 kbps**

7. Actual Data Rate

Here is done the average throughput calculation from transmitter perspective assuming the Receiver is not always available. So an estimate of the actual data rate can be calculated for a non-ideal environment by allowing for retries. Assuming a packet error rate of 25% and all packets that require a retry only require one retry, the total time to transmit a frame with one retry is:

| | |
|------------------------------|--|
| CSMA/CA (data frame) | 2.368 ms (default random back-off exponent of 3) |
| Data frame transmission | 4.256 ms |
| <i>MacAckWaitDuration</i> | 0.864 ms |
| CSMA/CA (data frame) | 2.368 ms |
| Data frame transmission | 4.256 ms |
| Turnaround time | 0.192 ms |
| Acknowledgement transmission | 0.352 ms |

| | |
|-------|-----------|
| Total | 14.656 ms |
|-------|-----------|

The time to transmit a frame with no retries is as calculated for the effective data rate: 7.168 ms.

Therefore, with 75% of data frames taking 7.168 ms and 25% of data frames taking 14.656 ms:

Average data frame transmission time = (7.168 x 0.75) + (14.656 x 0.25) = 9.04 ms

Assuming a 114-Byte payload, the achievable data rate is then given by:

Actual data rate = (114 x 8) / (9.04 x 10⁻³) = **101 kbps**

So, the transfer time for 1 MB of data will be:

$$\frac{2^{20}}{114} \times 9.04ms = 1 \text{ min } 23\text{sec}$$

To improve on this, we could use a random back-off exponent of 1 rather than the default value of 3. In this case, the CSMA/CA channel access time will default to the minimum Long Inter-Frame Spacing (LIFS) of 0.640 ms. This gives an actual data rate of 135 kbps and a transfer time of 1 min 2sec.

8. Appendix

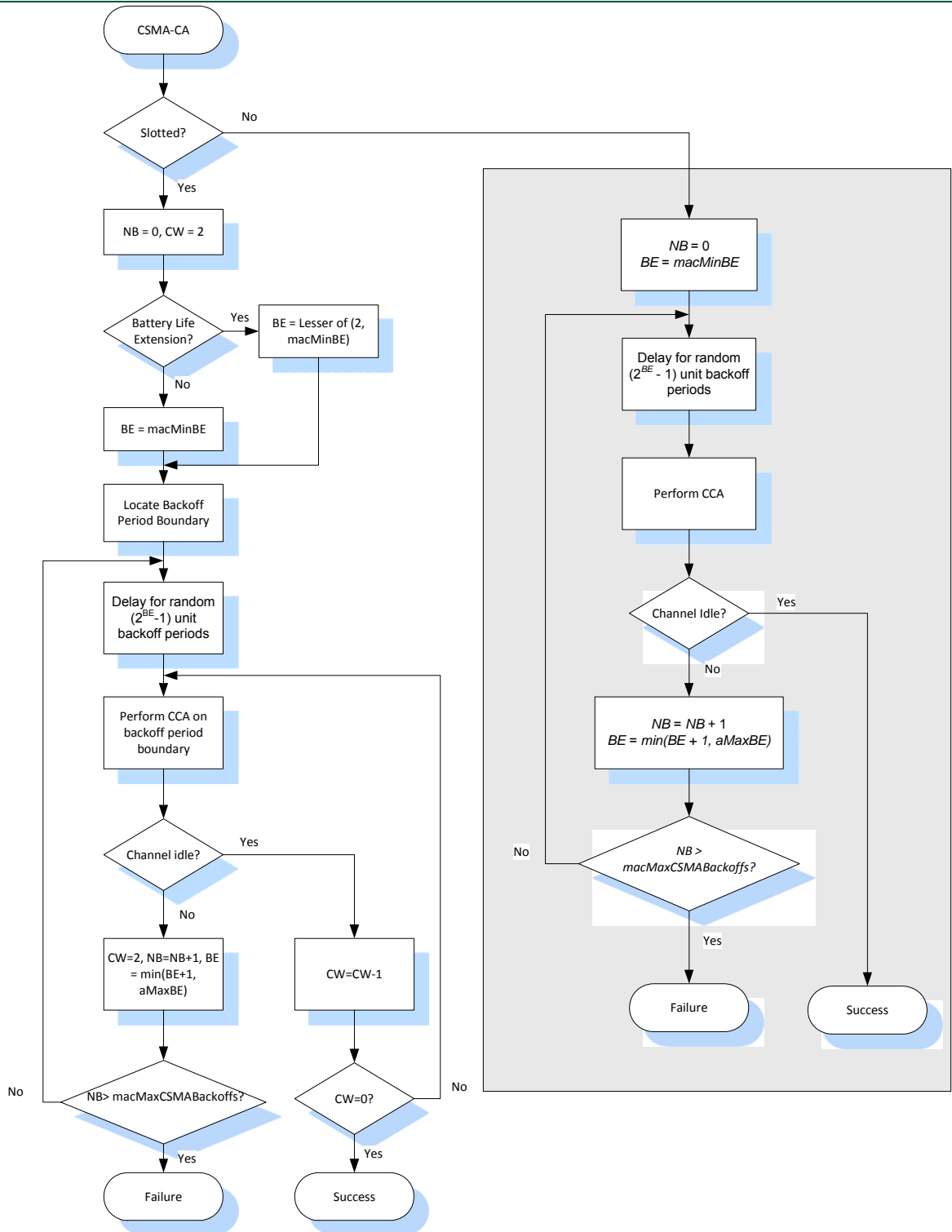

Figure 5: The Unslotted CSMA-CA Algorithm

9. Abbreviations

| | |
|---------|--|
| BE | Back-off Exponent |
| CAP | Contention Access Period |
| CCA | Clear Channel Assessment |
| CFP | Contention-Free Period |
| CSMA-CA | Carrier Sense Multiple Access with Collision Avoidance |
| FCS | Frame Check Sequence |
| LAN | Local Area Network |
| LR-WPAN | Low-Rate Wireless Personal Area Network |
| LIFS | Long Inter-Frame Spacing |
| MAC | Medium Access Control |
| MFR | MAC Footer |
| MHR | MAC Header |
| MPDU | MAC Protocol Data Unit |
| MSDU | MAC Service Data Unit |
| NB | Number of Back-off periods |
| PAN | Personal Area Network |
| PDU | Protocol Data Unit |
| PHR | PHY Header |
| PHY | Physical layer |
| PN | Pseudo-random Noise |
| PPDU | PHY Protocol Data Unit |
| PSDU | PHY Service Data Unit |
| SFD | Start-of-Frame Delimiter |
| SHR | Synchronisation Header |
| SIFS | Short Inter-Frame Spacing |

10. References

- [1] IEEE 802.15.4: Wireless Medium Access Control (MAC) and Physical Layer (PHY) Specifications for Low-Rate Wireless Personal Area Networks (LR-WPANs) - <http://standards.ieee.org/getieee802/download/802.15.4-2006.pdf>

11. Legal information

11.1 Definitions

Draft — The document is a draft version only. The content is still under internal review and subject to formal approval, which may result in modifications or additions. NXP Semiconductors does not give any representations or warranties as to the accuracy or completeness of information included herein and shall have no liability for the consequences of use of such information.

11.2 Disclaimers

Limited warranty and liability — Information in this document is believed to be accurate and reliable. However, NXP Semiconductors does not give any representations or warranties, expressed or implied, as to the accuracy or completeness of such information and shall have no liability for the consequences of use of such information. NXP Semiconductors takes no responsibility for the content in this document if provided by an information source outside of NXP Semiconductors.

In no event shall NXP Semiconductors be liable for any indirect, incidental, punitive, special or consequential damages (including - without limitation - lost profits, lost savings, business interruption, costs related to the removal or replacement of any products or rework charges) whether or not such damages are based on tort (including negligence), warranty, breach of contract or any other legal theory.

Notwithstanding any damages that customer might incur for any reason whatsoever, NXP Semiconductors' aggregate and cumulative liability towards customer for the products described herein shall be limited in accordance with the *Terms and conditions of commercial sale* of NXP Semiconductors.

Right to make changes — NXP Semiconductors reserves the right to make changes to information published in this document, including without limitation specifications and product descriptions, at any time and without notice. This document supersedes and replaces all information supplied prior to the publication hereof.

Suitability for use — NXP Semiconductors products are not designed, authorized or warranted to be suitable for use in life support, life-critical or safety-critical systems or equipment, nor in applications where failure or malfunction of an NXP Semiconductors product can reasonably be expected to result in personal injury, death or severe property or environmental damage. NXP Semiconductors and its suppliers accept no liability for inclusion and/or use of NXP Semiconductors products in such equipment or applications and therefore such inclusion and/or use is at the customer's own risk.

Applications — Applications that are described herein for any of these products are for illustrative purposes only. NXP Semiconductors makes no representation or warranty that such applications will be suitable for the specified use without further testing or modification.

Customers are responsible for the design and operation of their applications and products using NXP Semiconductors products, and NXP Semiconductors accepts no liability for any assistance with applications or customer product design. It is customer's sole responsibility to determine whether the NXP Semiconductors product is suitable and fit for the customer's applications and products planned, as well as for the planned

application and use of customer's third party customer(s). Customers should provide appropriate design and operating safeguards to minimize the risks associated with their applications and products.

NXP Semiconductors does not accept any liability related to any default, damage, costs or problem which is based on any weakness or default in the customer's applications or products, or the application or use by customer's third party customer(s). Customer is responsible for doing all necessary testing for the customer's applications and products using NXP Semiconductors products in order to avoid a default of the applications and the products or of the application or use by customer's third party customer(s). NXP does not accept any liability in this respect.

Export control — This document as well as the item(s) described herein may be subject to export control regulations. Export might require a prior authorization from competent authorities.

Translations — A non-English (translated) version of a document is for reference only. The English version shall prevail in case of any discrepancy between the translated and English versions.

Evaluation products — This product is provided on an "as is" and "with all faults" basis for evaluation purposes only. NXP Semiconductors, its affiliates and their suppliers expressly disclaim all warranties, whether express, implied or statutory, including but not limited to the implied warranties of non-infringement, merchantability and fitness for a particular purpose. The entire risk as to the quality, or arising out of the use or performance, of this product remains with customer.

In no event shall NXP Semiconductors, its affiliates or their suppliers be liable to customer for any special, indirect, consequential, punitive or incidental damages (including without limitation damages for loss of business, business interruption, loss of use, loss of data or information, and the like) arising out of the use of or inability to use the product, whether or not based on tort (including negligence), strict liability, breach of contract, breach of warranty or any other theory, even if advised of the possibility of such damages.

Notwithstanding any damages that customer might incur for any reason whatsoever (including without limitation, all damages referenced above and all direct or general damages), the entire liability of NXP Semiconductors, its affiliates and their suppliers and customer's exclusive remedy for all of the foregoing shall be limited to actual damages incurred by customer based on reasonable reliance up to the greater of the amount actually paid by customer for the product or five dollars (US\$5.00). The foregoing limitations, exclusions and disclaimers shall apply to the maximum extent permitted by applicable law, even if any remedy fails of its essential purpose.

11.3 Patents

Notice is herewith given that the subject device uses one or more of the following patents and that each of these patents may have corresponding patents in other jurisdictions.

11.4 Trademarks

Notice: All referenced brands, product names, service names and trademarks are property of their respective owners.

12. Contents

| | | |
|------------|--|-----------|
| 1. | Introduction | 3 |
| 2. | Application Overview | 3 |
| 3. | Channel Access Timing | 4 |
| 4. | Data Frame transmission..... | 5 |
| 4.1 | Maximum Data Payload | 5 |
| 4.2 | Data Frame Transfer Time | 6 |
| 5. | Acknowledgement frame Transmission..... | 7 |
| 5.1 | Timing | 7 |
| 5.2 | Retry Timing..... | 7 |
| 6. | Effective Data Rate..... | 8 |
| 7. | Actual Data Rate..... | 8 |
| 8. | Appendix..... | 10 |
| 9. | Abbreviations | 11 |
| 10. | References | 11 |
| 11. | Legal information | 12 |
| 11.1 | Definitions | 12 |
| 11.2 | Disclaimers..... | 12 |
| 11.3 | Patents..... | 12 |
| 11.4 | Trademarks | 12 |
| 12. | Contents..... | 13 |

Please be aware that important notices concerning this document and the product(s) described herein, have been included in the section 'Legal information'.
